

CALCULUS III

Paul Dawkins

Table of Contents

| | |
|--|------------|
| Preface | iii |
| Outline | iv |
| Three Dimensional Space | 1 |
| Introduction | 1 |
| The 3-D Coordinate System..... | 3 |
| Equations of Lines..... | 9 |
| Equations of Planes | 15 |
| Quadric Surfaces | 18 |
| Functions of Several Variables..... | 24 |
| Vector Functions | 31 |
| Calculus with Vector Functions | 40 |
| Tangent, Normal and Binormal Vectors | 43 |
| Arc Length with Vector Functions | 47 |
| Curvature..... | 50 |
| Velocity and Acceleration | 52 |
| Cylindrical Coordinates..... | 55 |
| Spherical Coordinates | 57 |
| Partial Derivatives | 62 |
| Introduction | 62 |
| Limits | 64 |
| Partial Derivatives | 69 |
| Interpretations of Partial Derivatives | 78 |
| Higher Order Partial Derivatives..... | 82 |
| Differentials..... | 86 |
| Chain Rule..... | 87 |
| Directional Derivatives | 97 |
| Applications of Partial Derivatives | 106 |
| Introduction | 106 |
| Tangent Planes and Linear Approximations | 107 |
| Gradient Vector, Tangent Planes and Normal Lines | 111 |
| Relative Minimums and Maximums | 113 |
| Absolute Minimums and Maximums | 122 |
| Lagrange Multipliers | 130 |
| Multiple Integrals | 140 |
| Introduction | 140 |
| Double Integrals | 141 |
| Iterated Integrals..... | 145 |
| Double Integrals Over General Regions..... | 152 |
| Double Integrals in Polar Coordinates | 163 |
| Triple Integrals | 174 |
| Triple Integrals in Cylindrical Coordinates | 182 |
| Triple Integrals in Spherical Coordinates..... | 185 |
| Change of Variables | 189 |
| Surface Area..... | 198 |
| Area and Volume Revisited | 201 |
| Line Integrals | 202 |
| Introduction | 202 |
| Vector Fields | 203 |
| Line Integrals – Part I..... | 208 |
| Line Integrals – Part II | 219 |
| Line Integrals of Vector Fields..... | 222 |
| Fundamental Theorem for Line Integrals..... | 225 |
| Conservative Vector Fields | 229 |

Calculus III

| | |
|---|------------|
| Green's Theorem..... | 236 |
| Curl and Divergence..... | 244 |
| Surface Integrals | 248 |
| Introduction..... | 248 |
| Parametric Surfaces..... | 249 |
| Surface Integrals..... | 255 |
| Surface Integrals of Vector Fields..... | 264 |
| Stokes' Theorem | 274 |
| Divergence Theorem..... | 279 |

Preface

Here are my online notes for my Calculus III course that I teach here at Lamar University. Despite the fact that these are my “class notes”, they should be accessible to anyone wanting to learn Calculus III or needing a refresher in some of the topics from the class.

These notes do assume that the reader has a good working knowledge of Calculus I topics including limits, derivatives and integration. It also assumes that the reader has a good knowledge of several Calculus II topics including some integration techniques, parametric equations, vectors, and knowledge of three dimensional space.

Here are a couple of warnings to my students who may be here to get a copy of what happened on a day that you missed.

1. Because I wanted to make this a fairly complete set of notes for anyone wanting to learn calculus I have included some material that I do not usually have time to cover in class and because this changes from semester to semester it is not noted here. You will need to find one of your fellow class mates to see if there is something in these notes that wasn't covered in class.
2. In general I try to work problems in class that are different from my notes. However, with Calculus III many of the problems are difficult to make up on the spur of the moment and so in this class my class work will follow these notes fairly close as far as worked problems go. With that being said I will, on occasion, work problems off the top of my head when I can to provide more examples than just those in my notes. Also, I often don't have time in class to work all of the problems in the notes and so you will find that some sections contain problems that weren't worked in class due to time restrictions.
3. Sometimes questions in class will lead down paths that are not covered here. I try to anticipate as many of the questions as possible in writing these up, but the reality is that I can't anticipate all the questions. Sometimes a very good question gets asked in class that leads to insights that I've not included here. You should always talk to someone who was in class on the day you missed and compare these notes to their notes and see what the differences are.
4. This is somewhat related to the previous three items, but is important enough to merit its own item. **THESE NOTES ARE NOT A SUBSTITUTE FOR ATTENDING CLASS!!** Using these notes as a substitute for class is liable to get you in trouble. As already noted not everything in these notes is covered in class and often material or insights not in these notes is covered in class.

Outline

Here is a listing and brief description of the material in this set of notes.

Three Dimensional Space

This is the only chapter that exists in two places in my notes. When I originally wrote these notes all of these topics were covered in Calculus II however, we have since moved several of them into Calculus III. So, rather than split the chapter up I have kept it in the Calculus II notes and also put a copy in the Calculus III notes. Many of the sections not covered in Calculus III will be used on occasion there anyway and so they serve as a quick reference for when we need them.

The 3-D Coordinate System – We will introduce the concepts and notation for the three dimensional coordinate system in this section.

Equations of Lines – In this section we will develop the various forms for the equation of lines in three dimensional space.

Equations of Planes – Here we will develop the equation of a plane.

Quadric Surfaces – In this section we will be looking at some examples of quadric surfaces.

Functions of Several Variables – A quick review of some important topics about functions of several variables.

Vector Functions – We introduce the concept of vector functions in this section. We concentrate primarily on curves in three dimensional space. We will however, touch briefly on surfaces as well.

Calculus with Vector Functions – Here we will take a quick look at limits, derivatives, and integrals with vector functions.

Tangent, Normal and Binormal Vectors – We will define the tangent, normal and binormal vectors in this section.

Arc Length with Vector Functions – In this section we will find the arc length of a vector function.

Curvature – We will determine the curvature of a function in this section.

Velocity and Acceleration – In this section we will revisit a standard application of derivatives. We will look at the velocity and acceleration of an object whose position function is given by a vector function.

Cylindrical Coordinates – We will define the cylindrical coordinate system in this section. The cylindrical coordinate system is an alternate coordinate system for the three dimensional coordinate system.

Spherical Coordinates – In this section we will define the spherical coordinate system. The spherical coordinate system is yet another alternate coordinate system for the three dimensional coordinate system.

Partial Derivatives

Limits – Taking limits of functions of several variables.

Partial Derivatives – In this section we will introduce the idea of partial derivatives as well as the standard notations and how to compute them.

Interpretations of Partial Derivatives – Here we will take a look at a couple of important interpretations of partial derivatives.

Higher Order Partial Derivatives – We will take a look at higher order partial derivatives in this section.

Differentials – In this section we extend the idea of differentials to functions of several variables.

Chain Rule – Here we will look at the chain rule for functions of several variables.

Directional Derivatives – We will introduce the concept of directional derivatives in this section. We will also see how to compute them and see a couple of nice facts pertaining to directional derivatives.

Applications of Partial Derivatives

Tangent Planes and Linear Approximations – We'll take a look at tangent planes to surfaces in this section as well as an application of tangent planes.

Gradient Vector, Tangent Planes and Normal Lines – In this section we'll see how the gradient vector can be used to find tangent planes and normal lines to a surface.

Relative Minimums and Maximums – Here we will see how to identify relative minimums and maximums.

Absolute Minimums and Maximums – We will find absolute minimums and maximums of a function over a given region.

Lagrange Multipliers – In this section we'll see how to use Lagrange Multipliers to find the absolute extrema for a function subject to a given constraint.

Multiple Integrals

Double Integrals – We will define the double integral in this section.

Iterated Integrals – In this section we will start looking at how we actually compute double integrals.

Double Integrals over General Regions – Here we will look at some general double integrals.

Double Integrals in Polar Coordinates – In this section we will take a look at evaluating double integrals using polar coordinates.

Triple Integrals – Here we will define the triple integral as well as how we evaluate them.

Triple Integrals in Cylindrical Coordinates – We will evaluate triple integrals using cylindrical coordinates in this section.

Triple Integrals in Spherical Coordinates – In this section we will evaluate triple integrals using spherical coordinates.

Change of Variables – In this section we will look at change of variables for double and triple integrals.

Surface Area – Here we look at the one real application of double integrals that we're going to look at in this material.

Area and Volume Revisited – We summarize the area and volume formulas from this chapter.

Line Integrals

Vector Fields – In this section we introduce the concept of a vector field.

Line Integrals – Part I – Here we will start looking at line integrals. In particular we will look at line integrals with respect to arc length.

Line Integrals – Part II – We will continue looking at line integrals in this section. Here we will be looking at line integrals with respect to x , y , and/or z .

Line Integrals of Vector Fields – Here we will look at a third type of line integrals, line integrals of vector fields.

Fundamental Theorem for Line Integrals – In this section we will look at a version of the fundamental theorem of calculus for line integrals of vector fields.

Conservative Vector Fields – Here we will take a somewhat detailed look at conservative vector fields and how to find potential functions.

Green's Theorem – We will give Green's Theorem in this section as well as an interesting application of Green's Theorem.

Curl and Divergence – In this section we will introduce the concepts of the curl and the divergence of a vector field. We will also give two vector forms of Green's Theorem.

Surface Integrals

Parametric Surfaces – In this section we will take a look at the basics of representing a surface with parametric equations. We will also take a look at a couple of applications.

Surface Integrals – Here we will introduce the topic of surface integrals. We will be working with surface integrals of functions in this section.

Surface Integrals of Vector Fields – We will look at surface integrals of vector fields in this section.

Stokes' Theorem – We will look at Stokes' Theorem in this section.

Divergence Theorem – Here we will take a look at the Divergence Theorem.

Three Dimensional Space

Introduction

In this chapter we will start taking a more detailed look at three dimensional space (3-D space or \mathbb{R}^3). This is a very important topic in Calculus III since a good portion of Calculus III is done in three (or higher) dimensional space.

We will be looking at the equations of graphs in 3-D space as well as vector valued functions and how we do calculus with them. We will also be taking a look at a couple of new coordinate systems for 3-D space.

This is the only chapter that exists in two places in my notes. When I originally wrote these notes all of these topics were covered in Calculus II however, we have since moved several of them into Calculus III. So, rather than split the chapter up I have kept it in the Calculus II notes and also put a copy in the Calculus III notes. Many of the sections not covered in Calculus III will be used on occasion there anyway and so they serve as a quick reference for when we need them.

Here is a list of topics in this chapter.

[The 3-D Coordinate System](#) – We will introduce the concepts and notation for the three dimensional coordinate system in this section.

[Equations of Lines](#) – In this section we will develop the various forms for the equation of lines in three dimensional space.

[Equations of Planes](#) – Here we will develop the equation of a plane.

[Quadric Surfaces](#) – In this section we will be looking at some examples of quadric surfaces.

[Functions of Several Variables](#) – A quick review of some important topics about functions of several variables.

[Vector Functions](#) – We introduce the concept of vector functions in this section. We concentrate primarily on curves in three dimensional space. We will however, touch briefly on surfaces as well.

[Calculus with Vector Functions](#) – Here we will take a quick look at limits, derivatives, and integrals with vector functions.

[Tangent, Normal and Binormal Vectors](#) – We will define the tangent, normal and binormal vectors in this section.

[Arc Length with Vector Functions](#) – In this section we will find the arc length of a vector function.

Curvature – We will determine the curvature of a function in this section.

Velocity and Acceleration – In this section we will revisit a standard application of derivatives. We will look at the velocity and acceleration of an object whose position function is given by a vector function.

Cylindrical Coordinates – We will define the cylindrical coordinate system in this section. The cylindrical coordinate system is an alternate coordinate system for the three dimensional coordinate system.

Spherical Coordinates – In this section we will define the spherical coordinate system. The spherical coordinate system is yet another alternate coordinate system for the three dimensional coordinate system.

The 3-D Coordinate System

We'll start the chapter off with a fairly short discussion introducing the 3-D coordinate system and the conventions that we'll be using. We will also take a brief look at how the different coordinate systems can change the graph of an equation.

Let's first get some basic notation out of the way. The 3-D coordinate system is often denoted by \mathbb{R}^3 . Likewise the 2-D coordinate system is often denoted by \mathbb{R}^2 and the 1-D coordinate system is denoted by \mathbb{R} . Also, as you might have guessed then a general n dimensional coordinate system is often denoted by \mathbb{R}^n .

Next, let's take a quick look at the basic coordinate system.

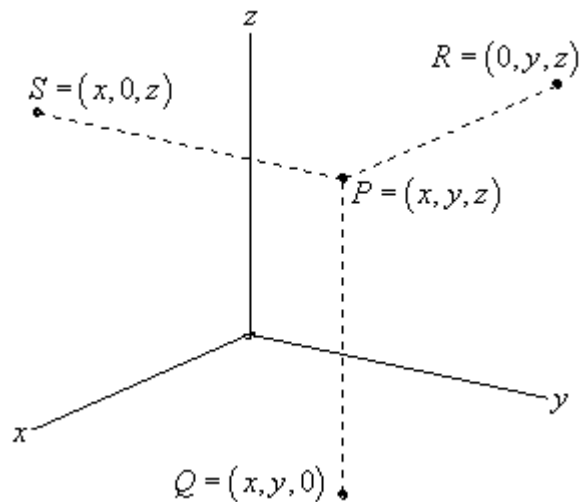

This is the standard placement of the axes in this class. It is assumed that only the positive directions are shown by the axes. If we need the negative axes for any reason we will put them in as needed.

Also note the various points on this sketch. The point P is the general point sitting out in 3-D space. If we start at P and drop straight down until we reach a z -coordinate of zero we arrive at the point Q . We say that Q sits in the xy -plane. The xy -plane corresponds to all the points which have a zero z -coordinate. We can also start at P and move in the other two directions as shown to get points in the xz -plane (this is S with a y -coordinate of zero) and the yz -plane (this is R with an x -coordinate of zero).

Collectively, the xy , xz , and yz -planes are sometimes called the coordinate planes. In the remainder of this class you will need to be able to deal with the various coordinate planes so make sure that you can.

Also, the point Q is often referred to as the projection of P in the xy -plane. Likewise, R is the projection of P in the yz -plane and S is the projection of P in the xz -plane.

Many of the formulas that you are used to working with in \mathbb{R}^2 have natural extensions in \mathbb{R}^3 . For instance the distance between two points in \mathbb{R}^2 is given by,

$$d(P_1, P_2) = \sqrt{(x_2 - x_1)^2 + (y_2 - y_1)^2}$$

While the distance between any two points in \mathbb{R}^3 is given by,

$$d(P_1, P_2) = \sqrt{(x_2 - x_1)^2 + (y_2 - y_1)^2 + (z_2 - z_1)^2}$$

Likewise, the general equation for a circle with center (h, k) and radius r is given by,

$$(x - h)^2 + (y - k)^2 = r^2$$

and the general equation for a sphere with center (h, k, l) and radius r is given by,

$$(x - h)^2 + (y - k)^2 + (z - l)^2 = r^2$$

With that said we do need to be careful about just translating everything we know about \mathbb{R}^2 into \mathbb{R}^3 and assuming that it will work the same way. A good example of this is in graphing to some extent. Consider the following example.

Example 1 Graph $x = 3$ in \mathbb{R} , \mathbb{R}^2 and \mathbb{R}^3 .

Solution

In \mathbb{R} we have a single coordinate system and so $x = 3$ is a point in a 1-D coordinate system.

In \mathbb{R}^2 the equation $x = 3$ tells us to graph all the points that are in the form $(3, y)$. This is a vertical line in a 2-D coordinate system.

In \mathbb{R}^3 the equation $x = 3$ tells us to graph all the points that are in the form $(3, y, z)$. If you go back and look at the coordinate plane points this is very similar to the coordinates for the yz -plane except this time we have $x = 3$ instead of $x = 0$. So, in a 3-D coordinate system this is a plane that will be parallel to the yz -plane and pass through the x -axis at $x = 3$.

Here is the graph of $x = 3$ in \mathbb{R} .

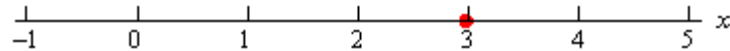

Here is the graph of $x = 3$ in \mathbb{R}^2 .

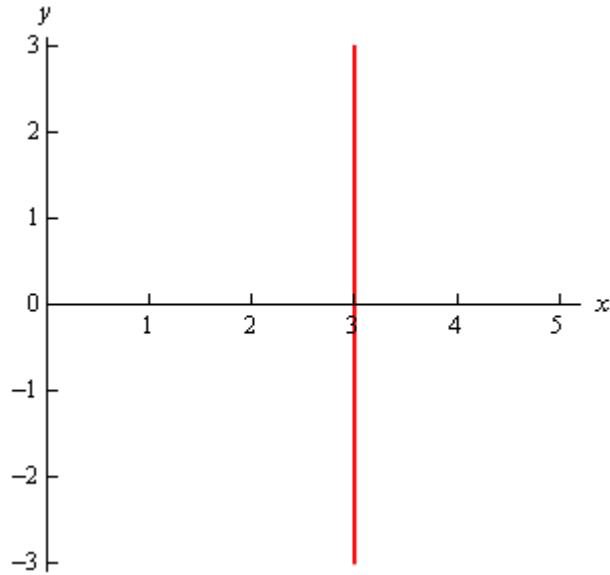

Finally, here is the graph of $x = 3$ in \mathbb{R}^3 . Note that we've presented this graph in two different styles. On the left we've got the traditional axis system and we're used to seeing and on the right we've put the graph in a box. Both views can be convenient on occasion to help with perspective and so we'll often do this with 3D graphs and sketches.

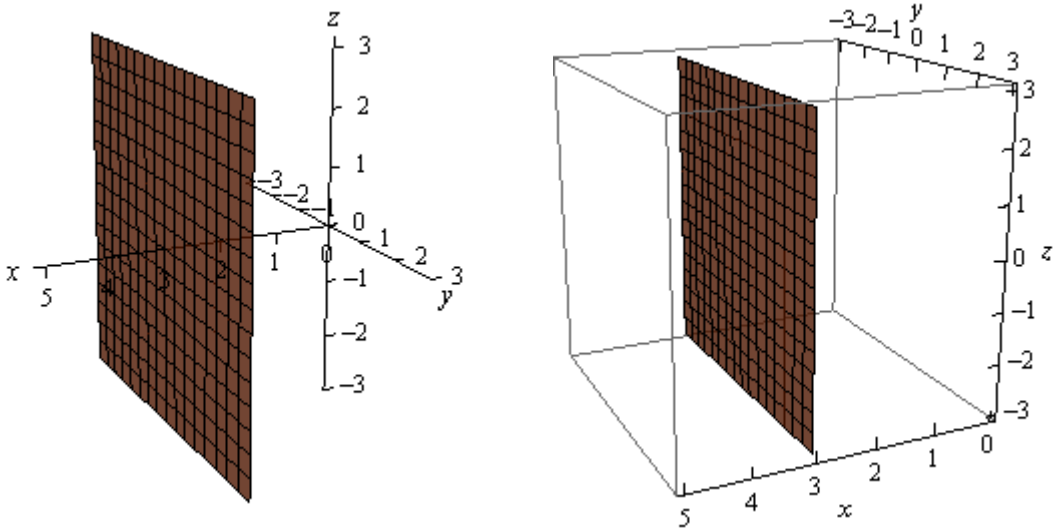

Note that at this point we can now write down the equations for each of the coordinate planes as well using this idea.

| | |
|---------|--------------|
| $z = 0$ | xy - plane |
| $y = 0$ | xz - plane |
| $x = 0$ | yz - plane |

Let's take a look at a slightly more general example.

Example 2 Graph $y = 2x - 3$ in \mathbb{R}^2 and \mathbb{R}^3 .

Solution

Of course we had to throw out \mathbb{R} for this example since there are two variables which means that we can't be in a 1-D space.

In \mathbb{R}^2 this is a line with slope 2 and a y intercept of -3.

However, in \mathbb{R}^3 this is not necessarily a line. Because we have not specified a value of z we are forced to let z take any value. This means that at any particular value of z we will get a copy of this line. So, the graph is then a vertical plane that lies over the line given by $y = 2x - 3$ in the xy -plane.

Here is the graph in \mathbb{R}^2 .

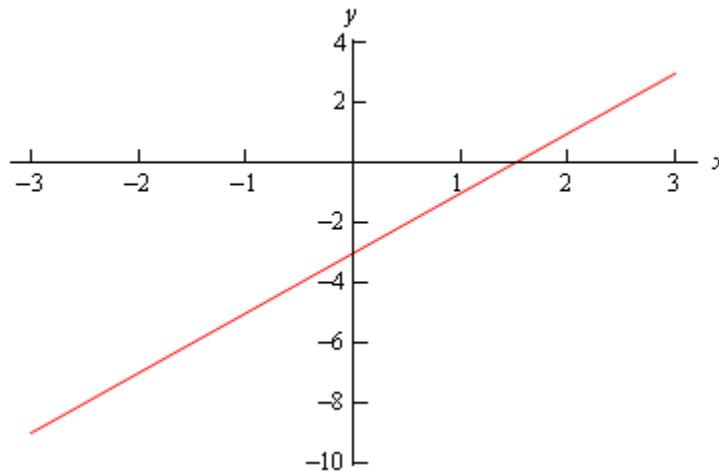

here is the graph in \mathbb{R}^3 .

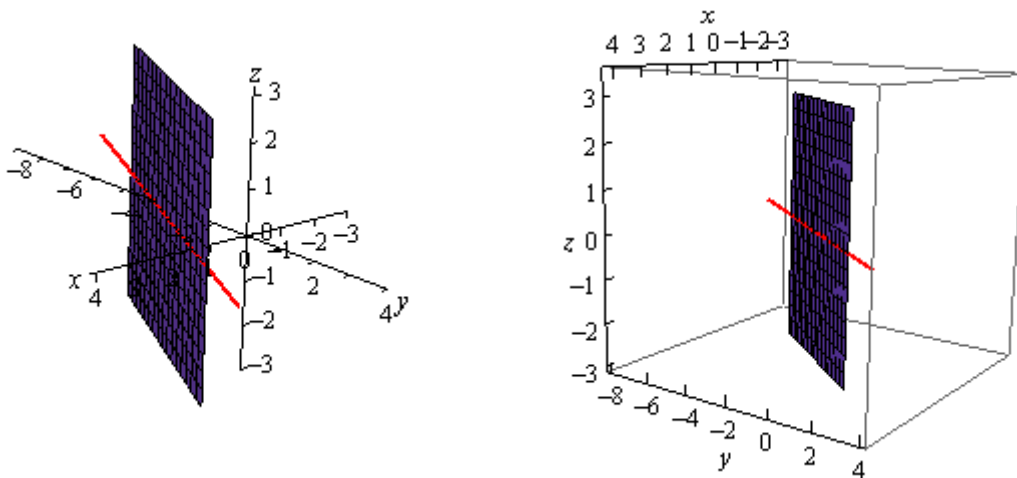

Notice that if we look to where the plane intersects the xy -plane we will get the graph of the line in \mathbb{R}^2 as noted in the above graph by the red line through the plane.

Let's take a look at one more example of the difference between graphs in the different coordinate systems.

Example 3 Graph $x^2 + y^2 = 4$ in \mathbb{R}^2 and \mathbb{R}^3 .

Solution

As with the previous example this won't have a 1-D graph since there are two variables.

In \mathbb{R}^2 this is a circle centered at the origin with radius 2.

In \mathbb{R}^3 however, as with the previous example, this may or may not be a circle. Since we have not specified z in any way we must assume that z can take on any value. In other words, at any value of z this equation must be satisfied and so at any value z we have a circle of radius 2 centered on the z -axis. This means that we have a cylinder of radius 2 centered on the z -axis.

Here are the graphs for this example.

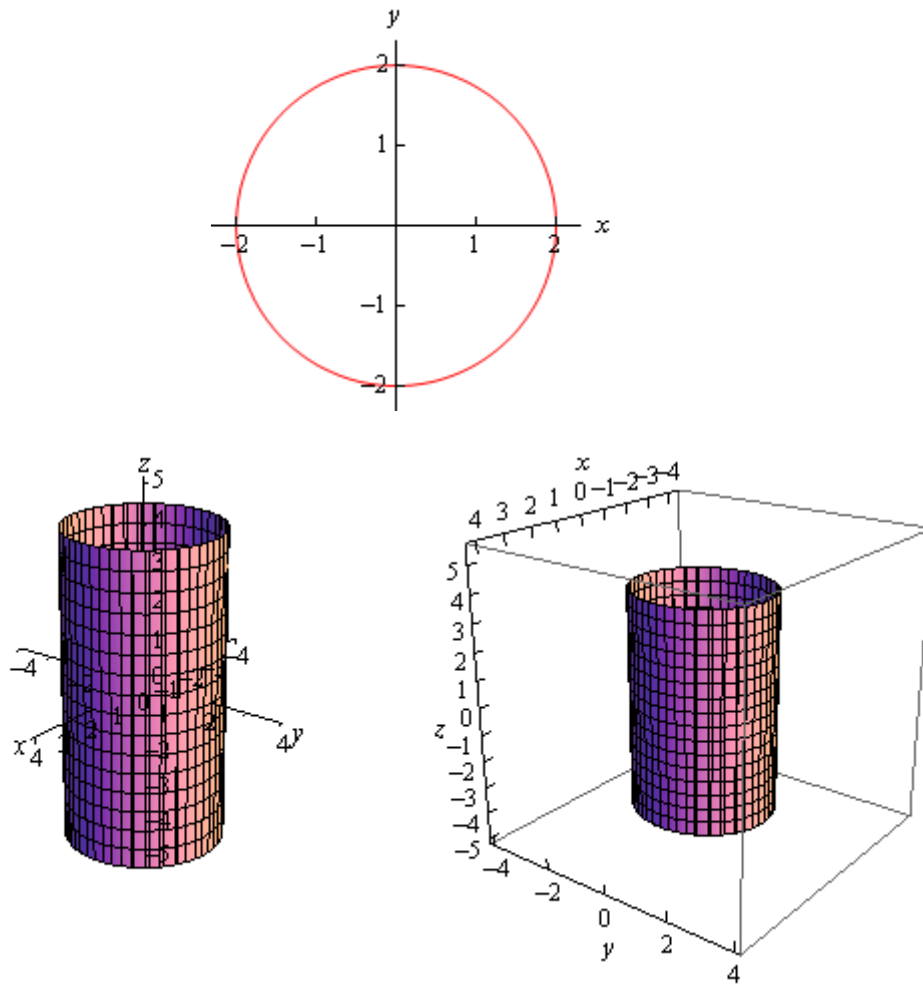

Notice that again, if we look to where the cylinder intersects the xy -plane we will again get the circle from \mathbb{R}^2 .

We need to be careful with the last two examples. It would be tempting to take the results of these and say that we can't graph lines or circles in \mathbb{R}^3 and yet that doesn't really make sense. There is no reason for there to not be graphs of lines or circles in \mathbb{R}^3 . Let's think about the example of the circle. To graph a circle in \mathbb{R}^3 we would need to do something like $x^2 + y^2 = 4$ at $z = 5$. This would be a circle of radius 2 centered on the z -axis at the level of $z = 5$. So, as long as we specify a z we will get a circle and not a cylinder. We will see an easier way to specify circles in a later section.

We could do the same thing with the line from the second example. However, we will be looking at lines in more generality in the next section and so we'll see a better way to deal with lines in \mathbb{R}^3 there.

The point of the examples in this section is to make sure that we are being careful with graphing equations and making sure that we always remember which coordinate system that we are in.

Another quick point to make here is that, as we've seen in the above examples, many graphs of equations in \mathbb{R}^3 are surfaces. That doesn't mean that we can't graph curves in \mathbb{R}^3 . We can and will graph curves in \mathbb{R}^3 as well as we'll see later in this chapter.

Equations of Lines

In this section we need to take a look at the equation of a line in \mathbb{R}^3 . As we saw in the previous section the equation $y = mx + b$ does not describe a line in \mathbb{R}^3 , instead it describes a plane. This doesn't mean however that we can't write down an equation for a line in 3-D space. We're just going to need a new way of writing down the equation of a curve.

So, before we get into the equations of lines we first need to briefly look at vector functions. We're going to take a more in depth look at vector functions later. At this point all that we need to worry about is notational issues and how they can be used to give the equation of a curve.

The best way to get an idea of what a vector function is and what its graph looks like is to look at an example. So, consider the following vector function.

$$\vec{r}(t) = \langle t, 1 \rangle$$

A vector function is a function that takes one or more variables, one in this case, and returns a vector. Note as well that a vector function can be a function of two or more variables. However, in those cases the graph may no longer be a curve in space.

The vector that the function gives can be a vector in whatever dimension we need it to be. In the example above it returns a vector in \mathbb{R}^2 . When we get to the real subject of this section, equations of lines, we'll be using a vector function that returns a vector in \mathbb{R}^3 .

Now, we want to determine the graph of the vector function above. In order to find the graph of our function we'll think of the vector that the vector function returns as a position vector for points on the graph. Recall that a position vector, say $\vec{v} = \langle a, b \rangle$, is a vector that starts at the origin and ends at the point (a, b) .

So, to get the graph of a vector function all we need to do is plug in some values of the variable and then plot the point that corresponds to each position vector we get out of the function and play connect the dots. Here are some evaluations for our example.

$$\vec{r}(-3) = \langle -3, 1 \rangle \quad \vec{r}(-1) = \langle -1, 1 \rangle \quad \vec{r}(2) = \langle 2, 1 \rangle \quad \vec{r}(5) = \langle 5, 1 \rangle$$

So, each of these are position vectors representing points on the graph of our vector function. The points,

$$(-3, 1) \quad (-1, 1) \quad (2, 1) \quad (5, 1)$$

are all points that lie on the graph of our vector function.

If we do some more evaluations and plot all the points we get the following sketch.

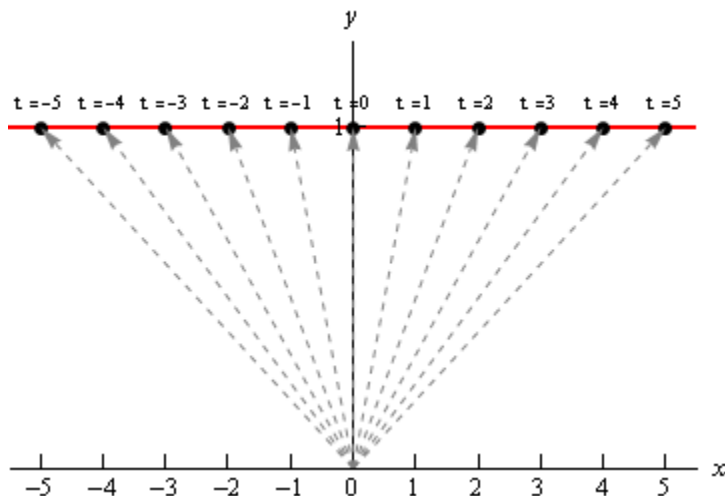

In this sketch we've included the position vector (in gray and dashed) for several evaluations as well as the t (above each point) we used for each evaluation. It looks like, in this case the graph of the vector equation is in fact the line $y = 1$.

Here's another quick example. Here is the graph of $\vec{r}(t) = \langle 6 \cos t, 3 \sin t \rangle$.

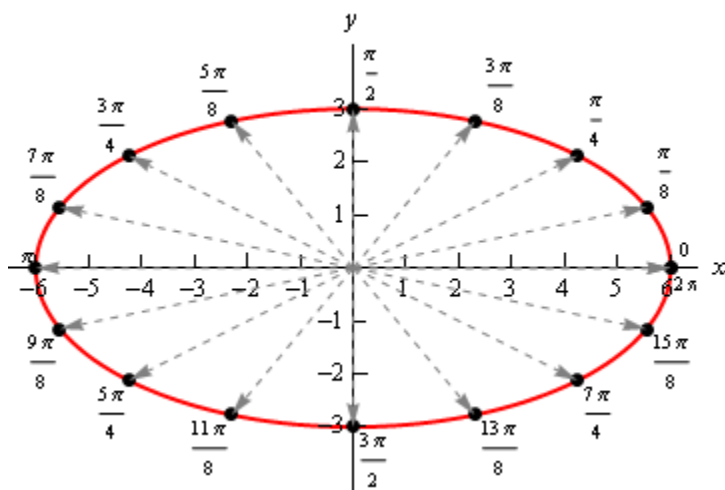

In this case we get an ellipse. It is important to not come away from this section with the idea that vector functions only graph out lines. We'll be looking at lines in this section, but the graphs of vector functions do not have to be lines as the example above shows.

We'll leave this brief discussion of vector functions with another way to think of the graph of a vector function. Imagine that a pencil/pen is attached to the end of the position vector and as we increase the variable the resulting position vector moves and as it moves the pencil/pen on the end sketches out the curve for the vector function.

Okay, we now need to move into the actual topic of this section. We want to write down the equation of a line in \mathbb{R}^3 and as suggested by the work above we will need a vector function to do this. To see how we're going to do this let's think about what we need to write down the

equation of a line in \mathbb{R}^2 . In two dimensions we need the slope (m) and a point that was on the line in order to write down the equation.

In \mathbb{R}^3 that is still all that we need except in this case the “slope” won’t be a simple number as it was in two dimensions. In this case we will need to acknowledge that a line can have a three dimensional slope. So, we need something that will allow us to describe a direction that is potentially in three dimensions. We already have a quantity that will do this for us. Vectors give directions and can be three dimensional objects.

So, let’s start with the following information. Suppose that we know a point that is on the line, $P_0 = (x_0, y_0, z_0)$, and that $\vec{v} = \langle a, b, c \rangle$ is some vector that is parallel to the line. Note, in all likelihood, \vec{v} will not be on the line itself. We only need \vec{v} to be parallel to the line. Finally, let $P = (x, y, z)$ be any point on the line.

Now, since our “slope” is a vector let’s also represent the two points on the line as vectors. We’ll do this with position vectors. So, let \vec{r}_0 and \vec{r} be the position vectors for P_0 and P respectively. Also, for no apparent reason, let’s define \vec{a} to be the vector with representation $\overrightarrow{P_0P}$.

We now have the following sketch with all these points and vectors on it.

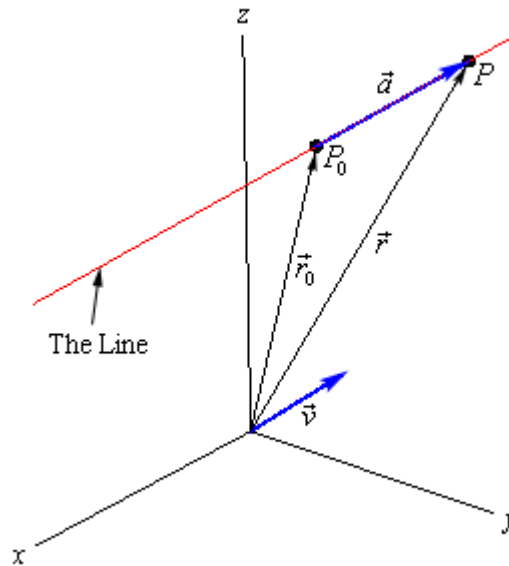

Now, we’ve shown the parallel vector, \vec{v} , as a position vector but it doesn’t need to be a position vector. It can be anywhere, a position vector, on the line or off the line, it just needs to be parallel to the line.

Next, notice that we can write \vec{r} as follows,

$$\vec{r} = \vec{r}_0 + \vec{a}$$

If you’re not sure about this go back and check out the sketch for vector addition in the [vector arithmetic](#) section. Now, notice that the vectors \vec{a} and \vec{v} are parallel. [Therefore](#) there is a number, t , such that

$$\vec{a} = t\vec{v}$$

We now have,

$$\vec{r} = \vec{r}_0 + t\vec{v} = \langle x_0, y_0, z_0 \rangle + t\langle a, b, c \rangle$$

This is called the **vector form of the equation of a line**. The only part of this equation that is not known is the t . Notice that $t\vec{v}$ will be a vector that lies along the line and it tells us how far from the original point that we should move. If t is positive we move away from the original point in the direction of \vec{v} (right in our sketch) and if t is negative we move away from the original point in the opposite direction of \vec{v} (left in our sketch). As t varies over all possible values we will completely cover the line. The following sketch shows this dependence on t of our sketch.

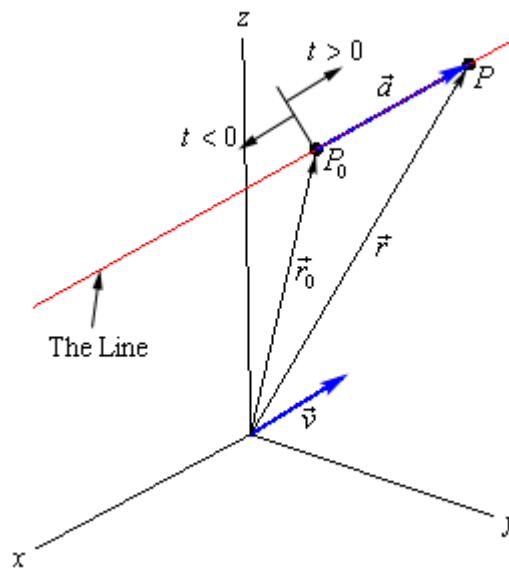

There are several other forms of the equation of a line. To get the first alternate form let's start with the vector form and do a slight rewrite.

$$\begin{aligned}\vec{r} &= \langle x_0, y_0, z_0 \rangle + t\langle a, b, c \rangle \\ \langle x, y, z \rangle &= \langle x_0 + ta, y_0 + tb, z_0 + tc \rangle\end{aligned}$$

The only way for two vectors to be equal is for the components to be equal. In other words,

$$\begin{aligned}x &= x_0 + ta \\ y &= y_0 + tb \\ z &= z_0 + tc\end{aligned}$$

This set of equations is called the **parametric form of the equation of a line**. Notice as well that this is really nothing more than an extension of the [parametric equations](#) we've seen previously. The only difference is that we are now working in three dimensions instead of two dimensions.

To get a point on the line all we do is pick a t and plug into either form of the line. In the vector form of the line we get a position vector for the point and in the parametric form we get the actual coordinates of the point.

There is one more form of the line that we want to look at. If we assume that a , b , and c are all non-zero numbers we can solve each of the equations in the parametric form of the line for t . We can then set all of them equal to each other since t will be the same number in each. Doing this gives the following,

$$\frac{x-x_0}{a} = \frac{y-y_0}{b} = \frac{z-z_0}{c}$$

This is called the **symmetric equations of the line**.

If one of a , b , or c does happen to be zero we can still write down the symmetric equations. To see this let's suppose that $b = 0$. In this case t will not exist in the parametric equation for y and so we will only solve the parametric equations for x and z for t . We then set those equal and acknowledge the parametric equation for y as follows,

$$\frac{x-x_0}{a} = \frac{z-z_0}{c} \quad y = y_0$$

Let's take a look at an example.

Example 1 Write down the equation of the line that passes through the points $(2, -1, 3)$ and $(1, 4, -3)$. Write down all three forms of the equation of the line.

Solution

To do this we need the vector \vec{v} that will be parallel to the line. This can be any vector as long as it's parallel to the line. In general, \vec{v} won't lie on the line itself. However, in this case it will. All we need to do is let \vec{v} be the vector that starts at the second point and ends at the first point. Since these two points are on the line the vector between them will also lie on the line and will hence be parallel to the line. So,

$$\vec{v} = \langle 1, -5, 6 \rangle$$

Note that the order of the points was chosen to reduce the number of minus signs in the vector. We could just have easily gone the other way.

Once we've got \vec{v} there really isn't anything else to do. To use the vector form we'll need a point on the line. We've got two and so we can use either one. We'll use the first point. Here is the vector form of the line.

$$\vec{r} = \langle 2, -1, 3 \rangle + t \langle 1, -5, 6 \rangle = \langle 2+t, -1-5t, 3+6t \rangle$$

Once we have this equation the other two forms follow. Here are the parametric equations of the line.

$$\begin{aligned}x &= 2 + t \\y &= -1 - 5t \\z &= 3 + 6t\end{aligned}$$

Here is the symmetric form.

$$\frac{x-2}{1} = \frac{y+1}{-5} = \frac{z-3}{6}$$

Example 2 Determine if the line that passes through the point $(0, -3, 8)$ and is parallel to the line given by $x = 10 + 3t$, $y = 12t$ and $z = -3 - t$ passes through the xz -plane. If it does give the coordinates of that point.

Solution

To answer this we will first need to write down the equation of the line. We know a point on the line and just need a parallel vector. We know that the new line must be parallel to the line given by the parametric equations in the problem statement. That means that any vector that is parallel to the given line must also be parallel to the new line.

Now recall that in the parametric form of the line the numbers multiplied by t are the components of the vector that is parallel to the line. Therefore, the vector,

$$\vec{v} = \langle 3, 12, -1 \rangle$$

is parallel to the given line and so must also be parallel to the new line.

The equation of new line is then,

$$\vec{r} = \langle 0, -3, 8 \rangle + t \langle 3, 12, -1 \rangle = \langle 3t, -3 + 12t, 8 - t \rangle$$

If this line passes through the xz -plane then we know that the y -coordinate of that point must be zero. So, let's set the y component of the equation equal to zero and see if we can solve for t . If we can, this will give the value of t for which the point will pass through the xz -plane.

$$-3 + 12t = 0 \quad \Rightarrow \quad t = \frac{1}{4}$$

So, the line does pass through the xz -plane. To get the complete coordinates of the point all we need to do is plug $t = \frac{1}{4}$ into any of the equations. We'll use the vector form.

$$\vec{r} = \left\langle 3\left(\frac{1}{4}\right), -3 + 12\left(\frac{1}{4}\right), 8 - \frac{1}{4} \right\rangle = \left\langle \frac{3}{4}, 0, \frac{31}{4} \right\rangle$$

Recall that this vector is the position vector for the point on the line and so the coordinates of the point where the line will pass through the xz -plane are $\left(\frac{3}{4}, 0, \frac{31}{4}\right)$.

Equations of Planes

In the first section of this chapter we saw a couple of equations of planes. However, none of those equations had three variables in them and were really extensions of graphs that we could look at in two dimensions. We would like a more general equation for planes.

So, let's start by assuming that we know a point that is on the plane, $P_0 = (x_0, y_0, z_0)$. Let's also suppose that we have a vector that is orthogonal (perpendicular) to the plane, $\vec{n} = \langle a, b, c \rangle$. This vector is called the **normal vector**. Now, assume that $P = (x, y, z)$ is any point in the plane.

Finally, since we are going to be working with vectors initially we'll let \vec{r}_0 and \vec{r} be the position vectors for P_0 and P respectively.

Here is a sketch of all these vectors.

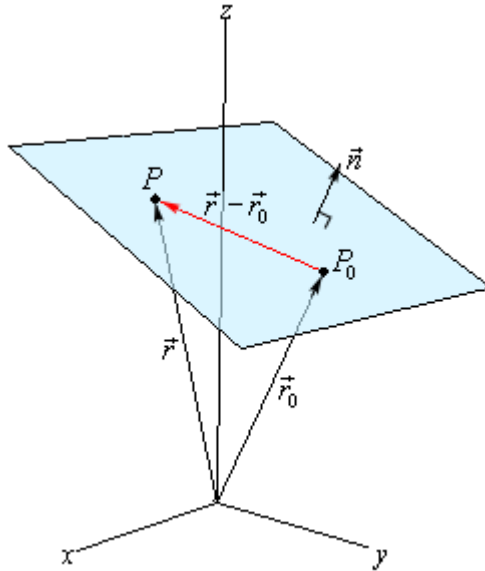

Notice that we added in the vector $\vec{r} - \vec{r}_0$ which will lie completely in the plane. Also notice that we put the normal vector on the plane, but there is actually no reason to expect this to be the case. We put it here to illustrate the point. It is completely possible that the normal vector does not touch the plane in any way.

Now, because \vec{n} is orthogonal to the plane, it's also orthogonal to any vector that lies in the plane. In particular it's orthogonal to $\vec{r} - \vec{r}_0$. Recall from the [Dot Product](#) section that two orthogonal vectors will have a dot product of zero. In other words,

$$\vec{n} \cdot (\vec{r} - \vec{r}_0) = 0 \quad \Rightarrow \quad \vec{n} \cdot \vec{r} = \vec{n} \cdot \vec{r}_0$$

This is called the **vector equation of the plane**.

A slightly more useful form of the equations is as follows. Start with the first form of the vector equation and write down a vector for the difference.

$$\begin{aligned}\langle a, b, c \rangle \cdot (\langle x, y, z \rangle - \langle x_0, y_0, z_0 \rangle) &= 0 \\ \langle a, b, c \rangle \cdot \langle x - x_0, y - y_0, z - z_0 \rangle &= 0\end{aligned}$$

Now, actually compute the dot product to get,

$$a(x - x_0) + b(y - y_0) + c(z - z_0) = 0$$

This is called the **scalar equation of plane**. Often this will be written as,

$$ax + by + cz = d$$

where $d = ax_0 + by_0 + cz_0$.

This second form is often how we are given equations of planes. Notice that if we are given the equation of a plane in this form we can quickly get a normal vector for the plane. A normal vector is,

$$\vec{n} = \langle a, b, c \rangle$$

Let's work a couple of examples.

Example 1 Determine the equation of the plane that contains the points $P = (1, -2, 0)$, $Q = (3, 1, 4)$ and $R = (0, -1, 2)$.

Solution

In order to write down the equation of plane we need a point (we've got three so we're cool there) and a normal vector. We need to find a normal vector. Recall however, that we saw how to do this in the [Cross Product](#) section.

We can form the following two vectors from the given points.

$$\vec{PQ} = \langle 2, 3, 4 \rangle \quad \vec{PR} = \langle -1, 1, 2 \rangle$$

These two vectors will lie completely in the plane since we formed them from points that were in the plane. Notice as well that there are many possible vectors to use here, we just chose two of the possibilities.

Now, we know that the cross product of two vectors will be orthogonal to both of these vectors. Since both of these are in the plane any vector that is orthogonal to both of these will also be orthogonal to the plane. Therefore, we can use the cross product as the normal vector.

$$\vec{n} = \vec{PQ} \times \vec{PR} = \begin{vmatrix} \vec{i} & \vec{j} & \vec{k} \\ 2 & 3 & 4 \\ -1 & 1 & 2 \end{vmatrix} = \begin{vmatrix} \vec{i} & \vec{j} \\ 2 & 3 \\ -1 & 1 \end{vmatrix} = 2\vec{i} - 8\vec{j} + 5\vec{k}$$

The equation of the plane is then,

$$2(x-1) - 8(y+2) + 5(z-0) = 0$$

$$2x - 8y + 5z = 18$$

We used P for the point, but could have used any of the three points.

Example 2 Determine if the plane given by $-x + 2z = 10$ and the line given by $\vec{r} = \langle 5, 2 - t, 10 + 4t \rangle$ are orthogonal, parallel or neither.

Solution

This is not as difficult a problem as it may at first appear to be. We can pick off a vector that is normal to the plane. This is $\vec{n} = \langle -1, 0, 2 \rangle$. We can also get a vector that is parallel to the line. This is $\vec{v} = \langle 0, -1, 4 \rangle$.

Now, if these two vectors are parallel then the line and the plane will be orthogonal. If you think about it this makes some sense. If \vec{n} and \vec{v} are parallel, then \vec{v} is orthogonal to the plane, but \vec{v} is also parallel to the line. So, if the two vectors are parallel the line and plane will be orthogonal.

Let's check this.

$$\vec{n} \times \vec{v} = \begin{vmatrix} \vec{i} & \vec{j} & \vec{k} \\ -1 & 0 & 2 \\ 0 & -1 & 4 \end{vmatrix} = \begin{vmatrix} \vec{i} & \vec{j} \\ -1 & 0 \\ 0 & -1 \end{vmatrix} = 2\vec{i} + 4\vec{j} + \vec{k} \neq \vec{0}$$

So, the vectors aren't parallel and so the plane and the line are not orthogonal.

Now, let's check to see if the plane and line are parallel. If the line is parallel to the plane then any vector parallel to the line will be orthogonal to the normal vector of the plane. In other words, if \vec{n} and \vec{v} are orthogonal then the line and the plane will be parallel.

Let's check this.

$$\vec{n} \cdot \vec{v} = 0 + 0 + 8 = 8 \neq 0$$

The two vectors aren't orthogonal and so the line and plane aren't parallel.

So, the line and the plane are neither orthogonal nor parallel.

Quadric Surfaces

In the previous two sections we've looked at lines and planes in three dimensions (or \mathbb{R}^3) and while these are used quite heavily at times in a Calculus class there are many other surfaces that are also used fairly regularly and so we need to take a look at those.

In this section we are going to be looking at quadric surfaces. Quadric surfaces are the graphs of any equation that can be put into the general form

$$Ax^2 + By^2 + Cz^2 + Dxy + Exz + Fyz + Gx + Hy + Iz + J = 0$$

where A, \dots, J are constants.

There is no way that we can possibly list all of them, but there are some standard equations so here is a list of some of the more common quadric surfaces.

Ellipsoid

Here is the general equation of an ellipsoid.

$$\frac{x^2}{a^2} + \frac{y^2}{b^2} + \frac{z^2}{c^2} = 1$$

Here is a sketch of a typical ellipsoid.

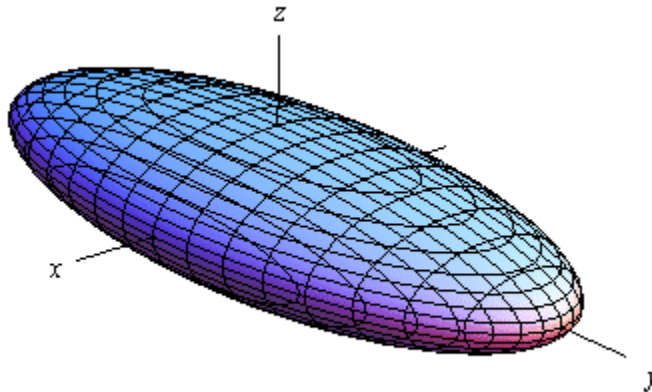

If $a = b = c$ then we will have a sphere.

Notice that we only gave the equation for the ellipsoid that has been centered on the origin. Clearly ellipsoids don't have to be centered on the origin. However, in order to make the discussion in this section a little easier we have chosen to concentrate on surfaces that are "centered" on the origin in one way or another.

Cone

Here is the general equation of a cone.

$$\frac{x^2}{a^2} + \frac{y^2}{b^2} = \frac{z^2}{c^2}$$

Here is a sketch of a typical cone.

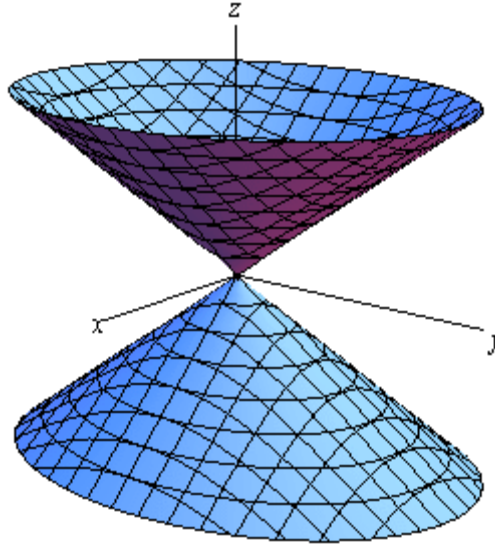

Note that this is the equation of a cone that will open along the z -axis. To get the equation of a cone that opens along one of the other axes all we need to do is make a slight modification of the equation. This will be the case for the rest of the surfaces that we'll be looking at in this section as well.

In the case of a cone the variable that sits by itself on one side of the equal sign will determine the axis that the cone opens up along. For instance, a cone that opens up along the x -axis will have the equation,

$$\frac{y^2}{b^2} + \frac{z^2}{c^2} = \frac{x^2}{a^2}$$

For most of the following surfaces we will not give the other possible formulas. We will however acknowledge how each formula needs to be changed to get a change of orientation for the surface.

Cylinder

Here is the general equation of a cylinder.

$$\frac{x^2}{a^2} + \frac{y^2}{b^2} = 1$$

This is a cylinder whose cross section is an ellipse. If $a = b$ we have a cylinder whose cross section is a circle. We'll be dealing with those kinds of cylinders more than the general form so the equation of a cylinder with a circular cross section is,

$$x^2 + y^2 = r^2$$

Here is a sketch of typical cylinder with an ellipse cross section.

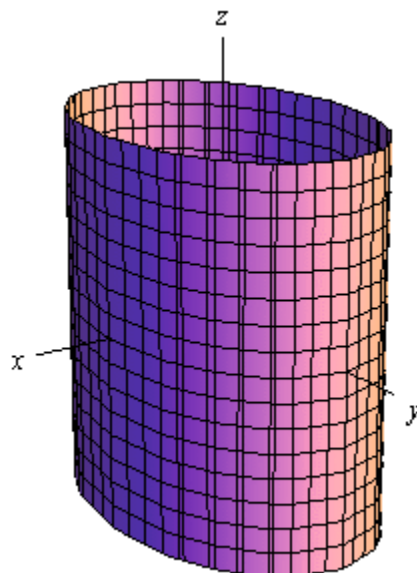

The cylinder will be centered on the axis corresponding to the variable that does not appear in the equation.

Be careful to not confuse this with a circle. In two dimensions it is a circle, but in three dimensions it is a cylinder.

Hyperboloid of One Sheet

Here is the equation of a hyperboloid of one sheet.

$$\frac{x^2}{a^2} + \frac{y^2}{b^2} - \frac{z^2}{c^2} = 1$$

Here is a sketch of a typical hyperboloid of one sheet.

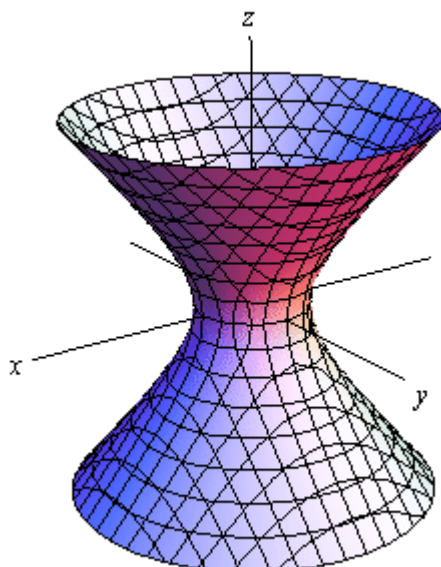

The variable with the negative in front of it will give the axis along which the graph is centered.

Hyperboloid of Two Sheets

Here is the equation of a hyperboloid of two sheets.

$$-\frac{x^2}{a^2} - \frac{y^2}{b^2} + \frac{z^2}{c^2} = 1$$

Here is a sketch of a typical hyperboloid of two sheets.

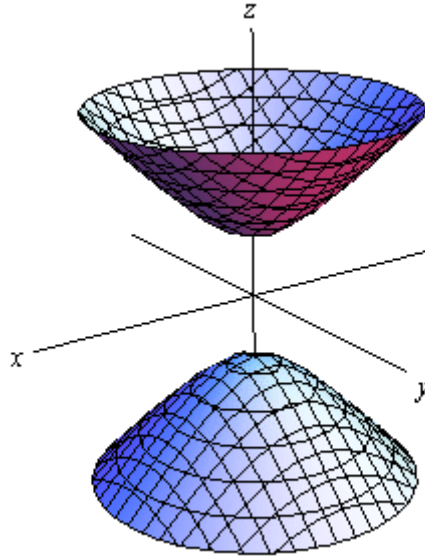

The variable with the positive in front of it will give the axis along which the graph is centered.

Notice that the only difference between the hyperboloid of one sheet and the hyperboloid of two sheets is the signs in front of the variables. They are exactly the opposite signs.

Elliptic Paraboloid

Here is the equation of an elliptic paraboloid.

$$\frac{x^2}{a^2} + \frac{y^2}{b^2} = \frac{z}{c}$$

As with cylinders this has a cross section of an ellipse and if $a = b$ it will have a cross section of a circle. When we deal with these we'll generally be dealing with the kind that have a circle for a cross section.

Here is a sketch of a typical elliptic paraboloid.

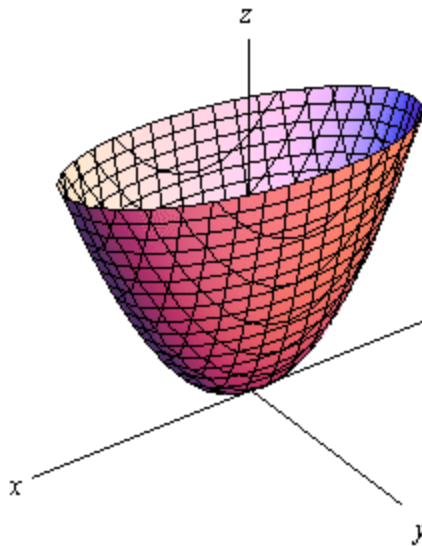

In this case the variable that isn't squared determines the axis upon which the paraboloid opens up. Also, the sign of c will determine the direction that the paraboloid opens. If c is positive then it opens up and if c is negative then it opens down.

Hyperbolic Paraboloid

Here is the equation of a hyperbolic paraboloid.

$$\frac{x^2}{a^2} - \frac{y^2}{b^2} = \frac{z}{c}$$

Here is a sketch of a typical hyperbolic paraboloid.

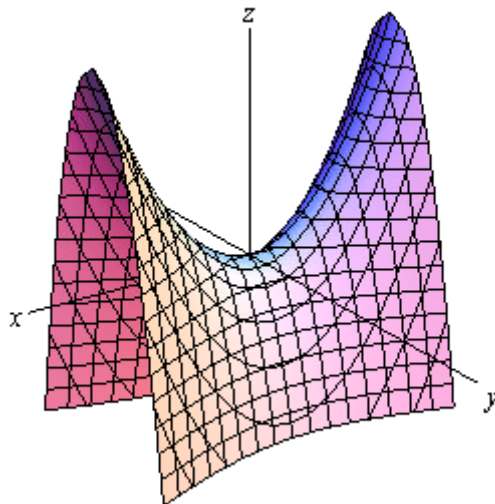

These graphs are vaguely saddle shaped and as with the elliptic paraboloid the sign of c will determine the direction in which the surface “opens up”. The graph above is shown for c positive.

With the both of the types of paraboloids discussed above the surface can be easily moved up or down by adding/subtracting a constant from the left side.

For instance

$$z = -x^2 - y^2 + 6$$

is an elliptic paraboloid that opens downward (be careful, the “-” is on the x and y instead of the z) and starts at $z = 6$ instead of $z = 0$.

Here are a couple of quick sketches of this surface.

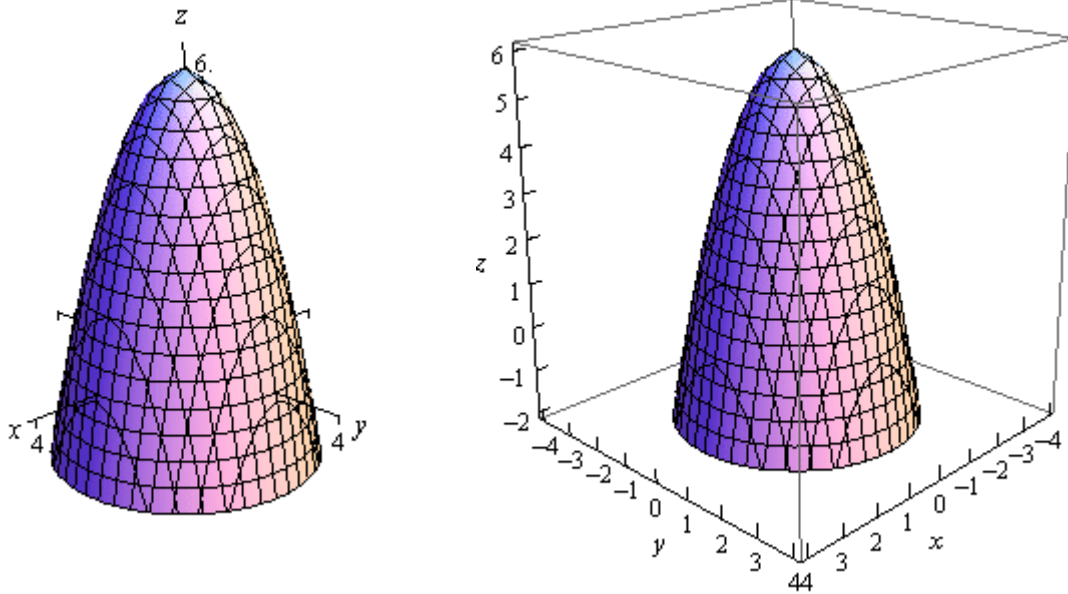

Note that we've given two forms of the sketch here. The sketch on the right has the standard set of axes but it is difficult to see the numbers on the axis. The sketch on the left has been “boxed” and this makes it easier to see the numbers to give a sense of perspective to the sketch. In most sketches that actually involve numbers on the axis system we will give both sketches to help get a feel for what the sketch looks like.

Functions of Several Variables

In this section we want to go over some of the basic ideas about functions of more than one variable.

First, remember that graphs of functions of two variables, $z = f(x, y)$ are surfaces in three dimensional space. For example here is the graph of $z = 2x^2 + 2y^2 - 4$.

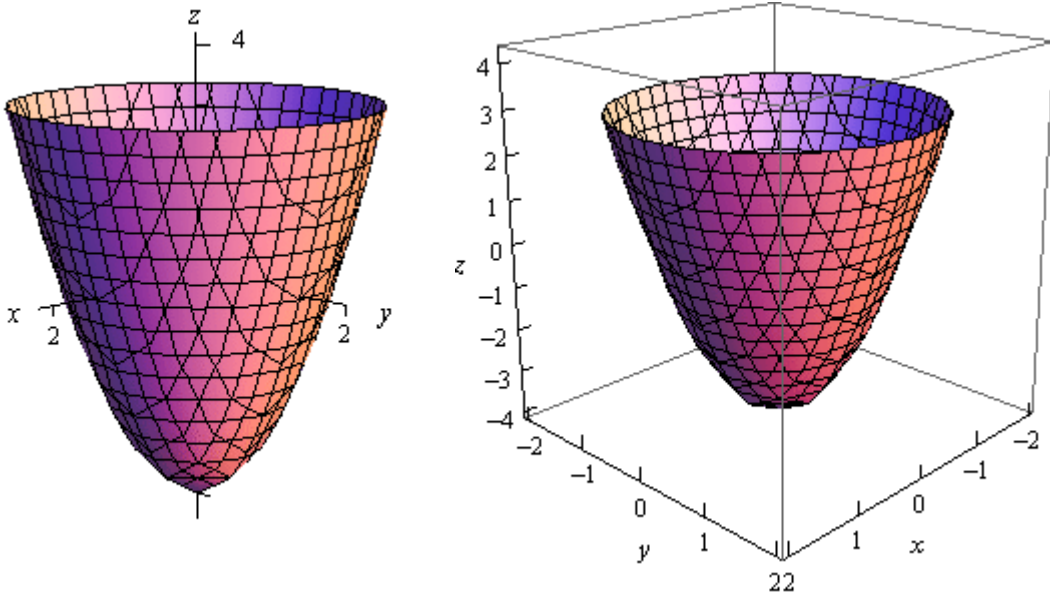

This is an elliptic paraboloid and is an example of a [quadric surface](#). We saw several of these in the previous section. We will be seeing quadric surfaces fairly regularly later on in Calculus III.

Another common graph that we'll be seeing quite a bit in this course is the graph of a plane. We have a convention for graphing planes that will make them a little easier to graph and hopefully visualize.

Recall that the [equation of a plane](#) is given by

$$ax + by + cz = d$$

or if we solve this for z we can write it in terms of function notation. This gives,

$$f(x, y) = Ax + By + D$$

To graph a plane we will generally find the intersection points with the three axes and then graph the triangle that connects those three points. This triangle will be a portion of the plane and it will give us a fairly decent idea on what the plane itself should look like. For example let's graph the plane given by,

$$f(x, y) = 12 - 3x - 4y$$

For purposes of graphing this it would probably be easier to write this as,

$$z = 12 - 3x - 4y \quad \Rightarrow \quad 3x + 4y + z = 12$$

Now, each of the intersection points with the three main coordinate axes is defined by the fact that two of the coordinates are zero. For instance, the intersection with the z -axis is defined by $x = y = 0$. So, the three intersection points are,

$$x\text{-axis} : (4, 0, 0)$$

$$y\text{-axis} : (0, 3, 0)$$

$$z\text{-axis} : (0, 0, 12)$$

Here is the graph of the plane.

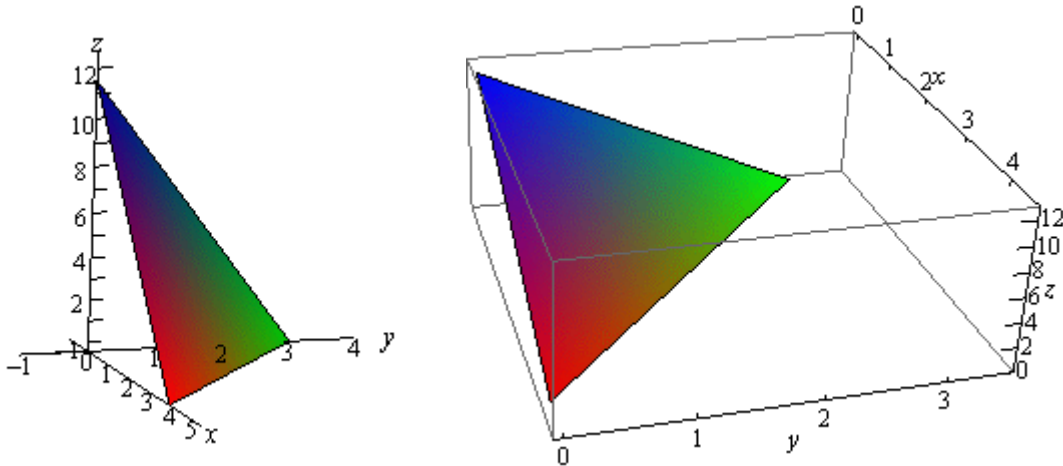

Now, to extend this out, graphs of functions of the form $w = f(x, y, z)$ would be four dimensional surfaces. Of course we can't graph them, but it doesn't hurt to point this out.

We next want to talk about the domains of functions of more than one variable. Recall that domains of functions of a single variable, $y = f(x)$, consisted of all the values of x that we could plug into the function and get back a real number. Now, if we think about it, this means that the domain of a function of a single variable is an interval (or intervals) of values from the number line, or one dimensional space.

The domain of functions of two variables, $z = f(x, y)$, are regions from two dimensional space and consist of all the coordinate pairs, (x, y) , that we could plug into the function and get back a real number.

Example 1 Determine the domain of each of the following.

(a) $f(x, y) = \sqrt{x + y}$ [Solution]

(b) $f(x, y) = \sqrt{x} + \sqrt{y}$ [Solution]

(c) $f(x, y) = \ln(9 - x^2 - 9y^2)$ [Solution]

Solution

(a) In this case we know that we can't take the square root of a negative number so this means that we must require,

$$x + y \geq 0$$

Here is a sketch of the graph of this region.

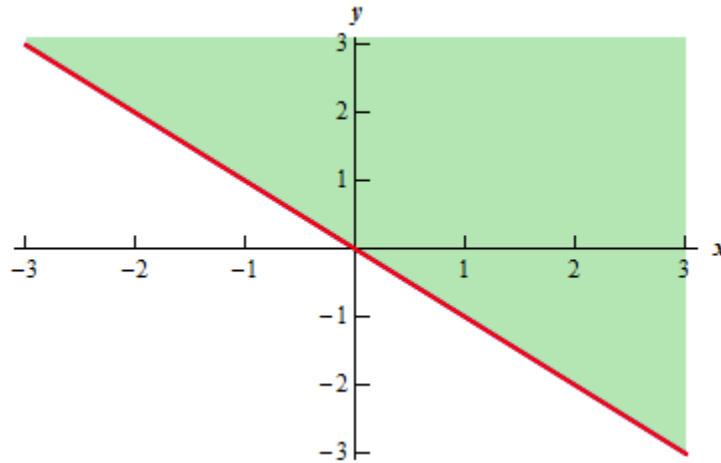

[\[Return to Problems\]](#)

(b) This function is different from the function in the previous part. Here we must require that,

$$x \geq 0 \quad \text{and} \quad y \geq 0$$

and they really do need to be separate inequalities. There is one for each square root in the function. Here is the sketch of this region.

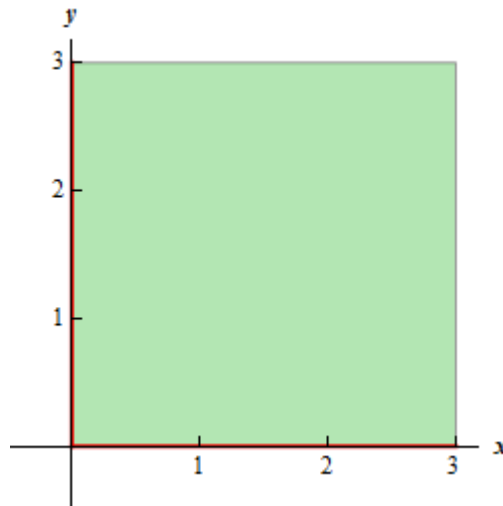

[\[Return to Problems\]](#)

(c) In this final part we know that we can't take the logarithm of a negative number or zero. Therefore we need to require that,

$$9 - x^2 - 9y^2 > 0 \quad \Rightarrow \quad \frac{x^2}{9} + y^2 < 1$$

and upon rearranging we see that we need to stay interior to an ellipse for this function. Here is a sketch of this region.

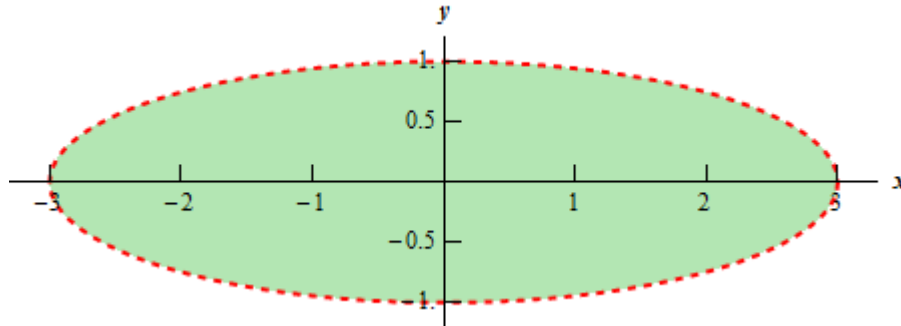

[\[Return to Problems\]](#)

Note that domains of functions of three variables, $w = f(x, y, z)$, will be regions in three dimensional space.

Example 2 Determine the domain of the following function,

$$f(x, y, z) = \frac{1}{\sqrt{x^2 + y^2 + z^2 - 16}}$$

Solution

In this case we have to deal with the square root and division by zero issues. These will require,

$$x^2 + y^2 + z^2 - 16 > 0 \quad \Rightarrow \quad x^2 + y^2 + z^2 > 16$$

So, the domain for this function is the set of points that lies completely outside a sphere of radius 4 centered at the origin.

The next topic that we should look at is that of **level curves** or **contour curves**. The level curves of the function $z = f(x, y)$ are two dimensional curves we get by setting $z = k$, where k is any number. So the equations of the level curves are $f(x, y) = k$. Note that sometimes the equation will be in the form $f(x, y, z) = 0$ and in these cases the equations of the level curves are $f(x, y, k) = 0$.

You've probably seen level curves (or contour curves, whatever you want to call them) before. If you've ever seen the elevation map for a piece of land, this is nothing more than the contour curves for the function that gives the elevation of the land in that area. Of course, we probably don't have the function that gives the elevation, but we can at least graph the contour curves.

Let's do a quick example of this.

Example 3 Identify the level curves of $f(x, y) = \sqrt{x^2 + y^2}$. Sketch a few of them.

Solution

First, for the sake of practice, let's identify what this surface given by $f(x, y)$ is. To do this let's rewrite it as,

$$z = \sqrt{x^2 + y^2}$$

Now, this equation is not listed in the [Quadric Surfaces](#) section, but if we square both sides we get,

$$z^2 = x^2 + y^2$$

and this is listed in that section. So, we have a cone, or at least a portion of a cone. Since we know that square roots will only return positive numbers, it looks like we've only got the upper half of a cone.

Note that this was not required for this problem. It was done for the practice of identifying the surface and this may come in handy down the road.

Now on to the real problem. The level curves (or contour curves) for this surface are given by the equation are found by substituting $z = k$. In the case of our example this is,

$$k = \sqrt{x^2 + y^2} \quad \Rightarrow \quad x^2 + y^2 = k^2$$

where k is any number. So, in this case, the level curves are circles of radius k with center at the origin.

We can graph these in one of two ways. We can either graph them on the surface itself or we can graph them in a two dimensional axis system. Here is each graph for some values of k .

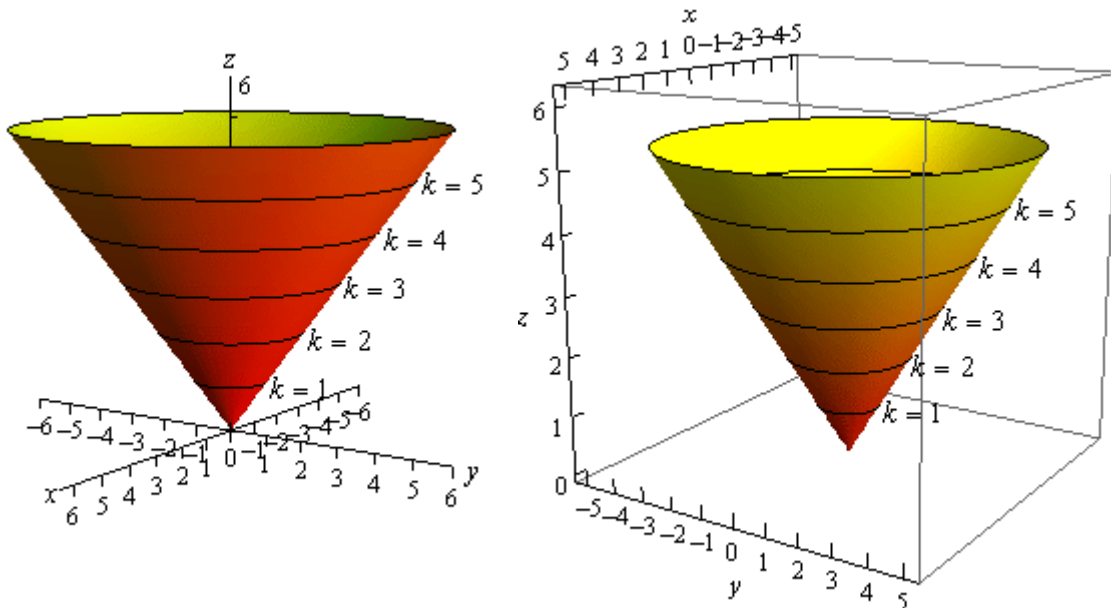

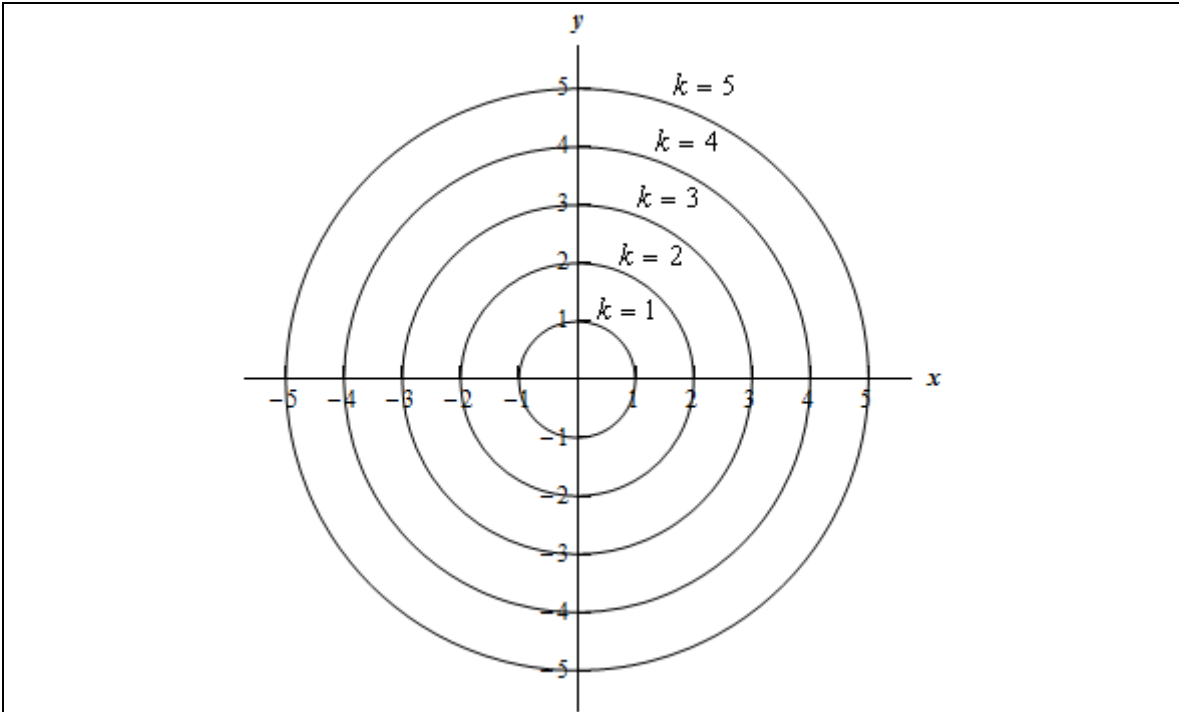

Note that we can think of contours in terms of the intersection of the surface that is given by $z = f(x, y)$ and the plane $z = k$. The contour will represent the intersection of the surface and the plane.

For functions of the form $f(x, y, z)$ we will occasionally look at **level surfaces**. The equations of level surfaces are given by $f(x, y, z) = k$ where k is any number.

The final topic in this section is that of **traces**. In some ways these are similar to contours. As noted above we can think of contours as the intersection of the surface given by $z = f(x, y)$ and the plane $z = k$. Traces of surfaces are curves that represent the intersection of the surface and the plane given by $x = a$ or $y = b$.

Let's take a quick look at an example of traces.

Example 4 Sketch the traces of $f(x, y) = 10 - 4x^2 - y^2$ for the plane $x = 1$ and $y = 2$.

Solution

We'll start with $x = 1$. We can get an equation for the trace by plugging $x = 1$ into the equation. Doing this gives,

$$z = f(1, y) = 10 - 4(1)^2 - y^2 \quad \Rightarrow \quad z = 6 - y^2$$

and this will be graphed in the plane given by $x = 1$.

Below are two graphs. The graph on the left is a graph showing the intersection of the surface and the plane given by $x = 1$. On the right is a graph of the surface and the trace that we are after in this part.

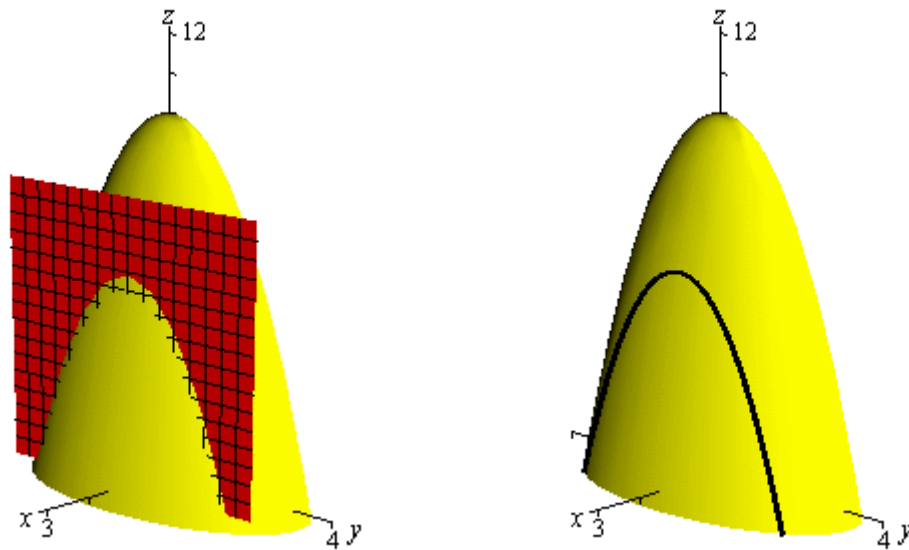

For $y = 2$ we will do pretty much the same thing that we did with the first part. Here is the equation of the trace,

$$z = f(x, 2) = 10 - 4x^2 - (2)^2 \Rightarrow z = 6 - 4x^2$$

and here are the sketches for this case.

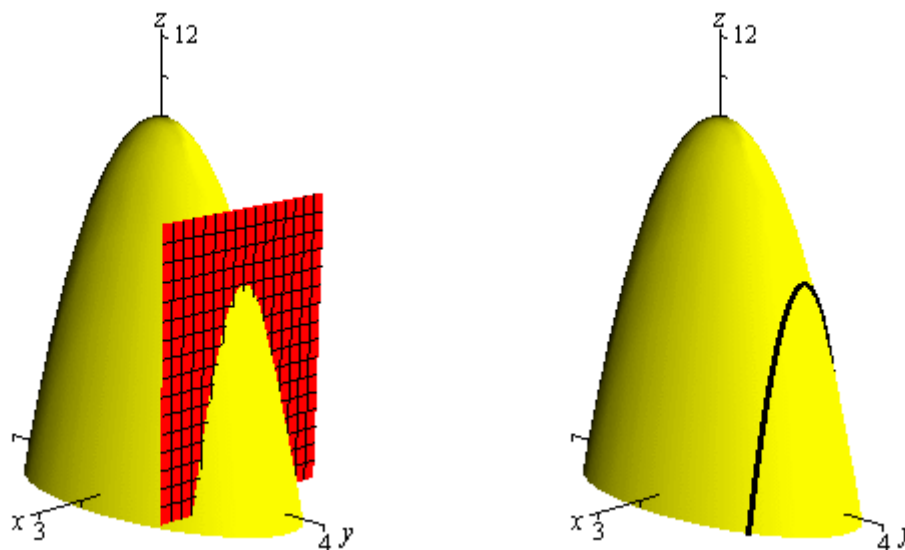

Vector Functions

We first saw vector functions back when we were looking at the [Equation of Lines](#). In that section we talked about them because we wrote down the equation of a line in \mathbb{R}^3 in terms of a **vector function** (sometimes called a **vector-valued function**). In this section we want to look a little closer at them and we also want to look at some vector functions in \mathbb{R}^3 other than lines.

A vector function is a function that takes one or more variables and returns a vector. We'll spend most of this section looking at vector functions of a single variable as most of the places where vector functions show up here will be vector functions of single variables. We will however briefly look at vector functions of two variables at the end of this section.

A vector functions of a single variable in \mathbb{R}^2 and \mathbb{R}^3 have the form,

$$\vec{r}(t) = \langle f(t), g(t) \rangle \qquad \vec{r}(t) = \langle f(t), g(t), h(t) \rangle$$

respectively, where $f(t)$, $g(t)$ and $h(t)$ are called the **component functions**.

The main idea that we want to discuss in this section is that of graphing and identifying the graph given by a vector function. Before we do that however, we should talk briefly about the domain of a vector function. The **domain** of a vector function is the set of all t 's for which all the component functions are defined.

Example 1 Determine the domain of the following function.

$$\vec{r}(t) = \langle \cos t, \ln(4-t), \sqrt{t+1} \rangle$$

Solution

The first component is defined for all t 's. The second component is only defined for $t < 4$. The third component is only defined for $t \geq -1$. Putting all of these together gives the following domain.

$$[-1, 4)$$

This is the largest possible interval for which all three components are defined.

Let's now move into looking at the graph of vector functions. In order to graph a vector function all we do is think of the vector returned by the vector function as a position vector for points on the graph. Recall that a position vector, say $\vec{v} = \langle a, b, c \rangle$, is a vector that starts at the origin and ends at the point (a, b, c) .

So, in order to sketch the graph of a vector function all we need to do is plug in some values of t and then plot points that correspond to the resulting position vector we get out of the vector function.

Because it is a little easier to visualize things we'll start off by looking at graphs of vector functions in \mathbb{R}^2 .

Example 2 Sketch the graph of each of the following vector functions.

(a) $\vec{r}(t) = \langle t, 1 \rangle$ [Solution]

(b) $\vec{r}(t) = \langle t, t^3 - 10t + 7 \rangle$ [Solution]

Solution

(a) $\vec{r}(t) = \langle t, 1 \rangle$

Okay, the first thing that we need to do is plug in a few values of t and get some position vectors. Here are a few,

$$\vec{r}(-3) = \langle -3, 1 \rangle \quad \vec{r}(-1) = \langle -1, 1 \rangle \quad \vec{r}(2) = \langle 2, 1 \rangle \quad \vec{r}(5) = \langle 5, 1 \rangle$$

So, what this tells us is that the following points are all on the graph of this vector function.

$$(-3, 1) \quad (-1, 1) \quad (2, 1) \quad (5, 1)$$

Here is a sketch of this vector function.

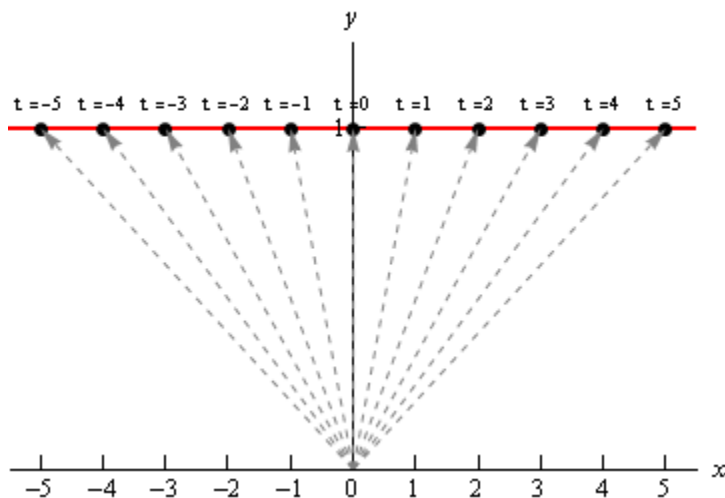

In this sketch we've included many more evaluations than just those above. Also note that we've put in the position vectors (in gray and dashed) so you can see how all this is working. Note however, that in practice the position vectors are generally not included in the sketch.

In this case it looks like we've got the graph of the line $y = 1$.

[\[Return to Problems\]](#)

(b) $\vec{r}(t) = \langle t, t^3 - 10t + 7 \rangle$

Here are a couple of evaluations for this vector function.

$$\vec{r}(-3) = \langle -3, 10 \rangle \quad \vec{r}(-1) = \langle -1, 16 \rangle \quad \vec{r}(1) = \langle 1, -2 \rangle \quad \vec{r}(3) = \langle 3, 4 \rangle$$

So, we've got a few points on the graph of this function. However, unlike the first part this isn't really going to be enough points to get a good idea of this graph. In general, it can take quite a

few function evaluations to get an idea of what the graph is and it's usually easier to use a computer to do the graphing.

Here is a sketch of this graph. We've put in a few vectors/evaluations to illustrate them, but the reality is that we did have to use a computer to get a good sketch here.

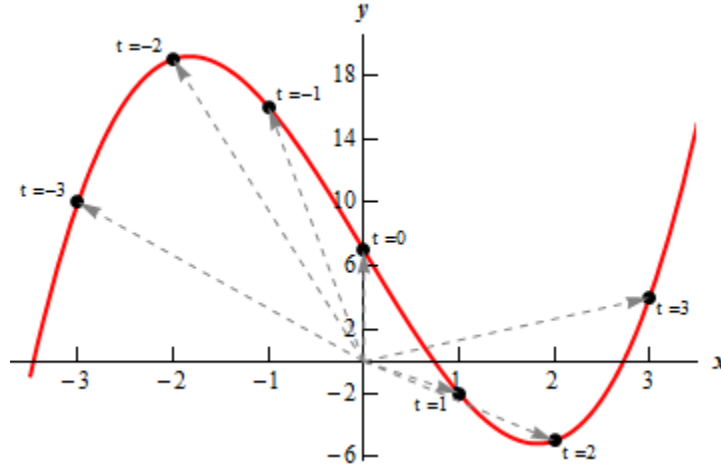

[\[Return to Problems\]](#)

Both of the vector functions in the above example were in the form,

$$\vec{r}(t) = \langle t, g(t) \rangle$$

and what we were really sketching is the graph of $y = g(x)$ as you probably caught onto. Let's graph a couple of other vector functions that do not fall into this pattern.

Example 3 Sketch the graph of each of the following vector functions.

(a) $\vec{r}(t) = \langle 6 \cos t, 3 \sin t \rangle$ [\[Solution\]](#)

(b) $\vec{r}(t) = \langle t - 2 \sin t, t^2 \rangle$ [\[Solution\]](#)

Solution

As we saw in the last part of the previous example it can really take quite a few function evaluations to really be able to sketch the graph of a vector function. Because of that we'll be skipping all the function evaluations here and just giving the graph. The main point behind this set of examples is to not get you too locked into the form we were looking at above. The first part will also lead to an important idea that we'll discuss after this example.

So, with that said here are the sketches of each of these.

(a) $\vec{r}(t) = \langle 6 \cos t, 3 \sin t \rangle$

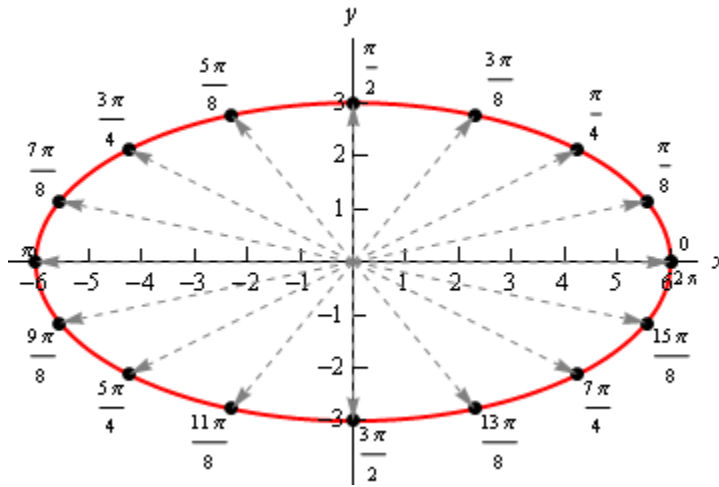

So, in this case it looks like we've got an ellipse.

[\[Return to Problems\]](#)

(b) $\vec{r}(t) = \langle t - 2 \sin t, t^2 \rangle$

Here's the sketch for this vector function.

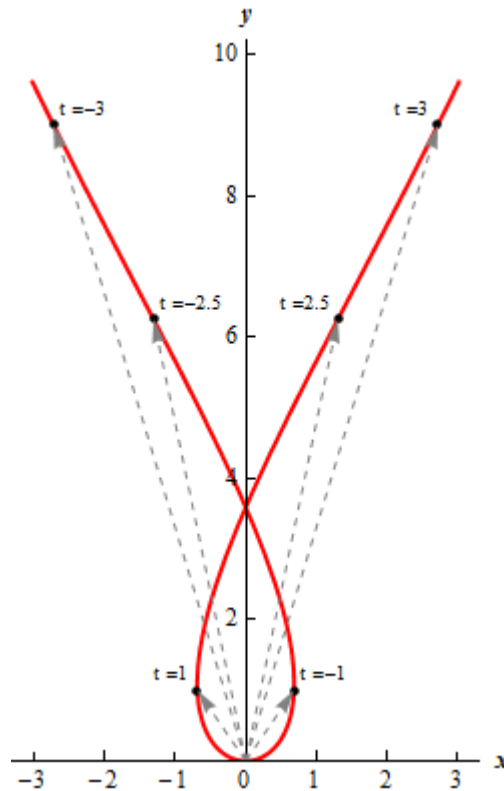

[\[Return to Problems\]](#)

Before we move on to vector functions in \mathbb{R}^3 let's go back and take a quick look at the first vector function we sketched in the previous example, $\vec{r}(t) = \langle 6 \cos t, 3 \sin t \rangle$. The fact that we

got an ellipse here should not come as a surprise to you. We know that the first component function gives the x coordinate and the second component function gives the y coordinates of the point that we graph. If we strip these out to make this clear we get,

$$x = 6 \cos t \qquad y = 3 \sin t$$

This should look familiar to you. Back when we were looking at [Parametric Equations](#) we saw that this was nothing more than one of the sets of parametric equations that gave an ellipse.

This is an important idea in the study of vector functions. Any vector function can be broken down into a set of parametric equations that represent the same graph. In general, the two dimensional vector function, $\vec{r}(t) = \langle f(t), g(t) \rangle$, can be broken down into the parametric equations,

$$x = f(t) \qquad y = g(t)$$

Likewise, a three dimensional vector function, $\vec{r}(t) = \langle f(t), g(t), h(t) \rangle$, can be broken down into the parametric equations,

$$x = f(t) \qquad y = g(t) \qquad z = h(t)$$

Do not get too excited about the fact that we're now looking at parametric equations in \mathbb{R}^3 . They work in exactly the same manner as parametric equations in \mathbb{R}^2 which we're used to dealing with already. The only difference is that we now have a third component.

Let's take a look at a couple of graphs of vector functions.

Example 4 Sketch the graph of the following vector function.

$$\vec{r}(t) = \langle 2 - 4t, -1 + 5t, 3 + t \rangle$$

Solution

Notice that this is nothing more than a line. It might help if we rewrite it a little.

$$\vec{r}(t) = \langle 2, -1, 3 \rangle + t \langle -4, 5, 1 \rangle$$

In this form we can see that this is the equation of a line that goes through the point $(2, -1, 3)$ and is parallel to the vector $\vec{v} = \langle -4, 5, 1 \rangle$.

To graph this line all that we need to do is plot the point and then sketch in the parallel vector. In order to get the sketch will assume that the vector is on the line and will start at the point in the line. To sketch in the line all we do this is extend the parallel vector into a line.

Here is a sketch.

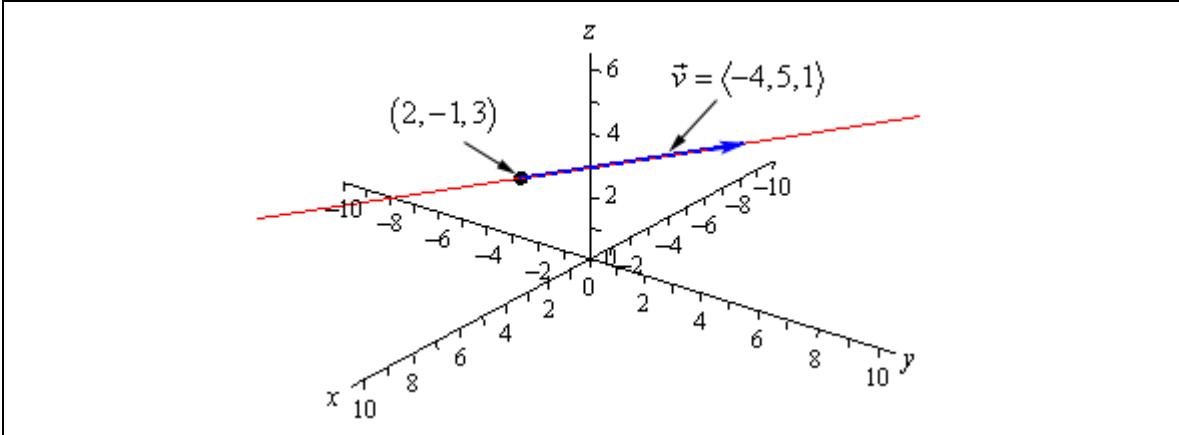

Example 5 Sketch the graph of the following vector function.

$$\vec{r}(t) = \langle 2 \cos t, 2 \sin t, 3 \rangle$$

Solution

In this case to see what we've got for a graph let's get the parametric equations for the curve.

$$x = 2 \cos t \qquad y = 2 \sin t \qquad z = 3$$

If we ignore the z equation for a bit we'll recall (hopefully) that the parametric equations for x and y give a circle of radius 2 centered on the origin (or about the z -axis since we are in \mathbb{R}^3).

Now, all the parametric equations here tell us is that no matter what is going on in the graph all the z coordinates must be 3. So, we get a circle of radius 2 centered on the z -axis and at the level of $z = 3$.

Here is a sketch.

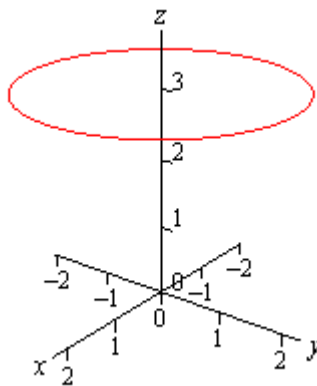

Note that it is very easy to modify the above vector function to get a circle centered on the x or y -axis as well. For instance,

$$\vec{r}(t) = \langle 10 \sin t, -3, 10 \cos t \rangle$$

will be a circle of radius 10 centered on the y -axis and at $y = -3$. In other words, as long as two of the terms are a sine and a cosine (with the same coefficient) and the other is a fixed number then we will have a circle that is centered on the axis that is given by the fixed number.

Let's take a look at a modification of this.

Example 6 Sketch the graph of the following vector function.

$$\vec{r}(t) = \langle 4 \cos t, 4 \sin t, t \rangle$$

Solution

If this one had a constant in the z component we would have another circle. However, in this case we don't have a constant. Instead we've got a t and that will change the curve. However, because the x and y component functions are still a circle in parametric equations our curve should have a circular nature to it in some way.

In fact, the only change is in the z component and as t increases the z coordinate will increase. Also, as t increases the x and y coordinates will continue to form a circle centered on the z -axis. Putting these two ideas together tells us that as we increase t the circle that is being traced out in the x and y directions should also be rising.

Here is a sketch of this curve.

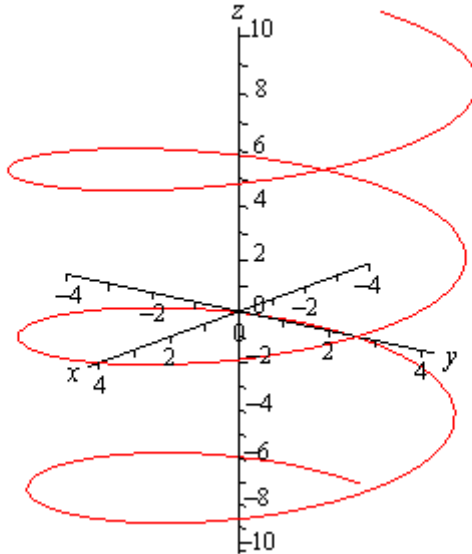

So, we've got a helix (or spiral, depending on what you want to call it) here.

As with circles the component that has the t will determine the axis that the helix rotates about. For instance,

$$\vec{r}(t) = \langle t, 6 \cos t, 6 \sin t \rangle$$

is a helix that rotates around the x -axis.

Also note that if we allow the coefficients on the sine and cosine for both the circle and helix to be different we will get ellipses.

For example,

$$\vec{r}(t) = \langle 9 \cos t, t, 2 \sin t \rangle$$

will be a helix that rotates about the y -axis and is in the shape of an ellipse.

There is a nice formula that we should derive before moving onto vector functions of two variables.

Example 7 Determine the vector equation for the line segment starting at the point $P = (x_1, y_1, z_1)$ and ending at the point $Q = (x_2, y_2, z_2)$.

Solution

It is important to note here that we only want the equation of the line segment that starts at P and ends at Q . We don't want any other portion of the line and we do want the direction of the line segment preserved as we increase t . With all that said, let's not worry about that and just find the vector equation of the line that passes through the two points. Once we have this we will be able to get what we're after.

So, we need a point on the line. We've got two and we will use P . We need a vector that is parallel to the line and since we've got two points we can find the vector between them. This vector will lie on the line and hence be parallel to the line. Also, let's remember that we want to preserve the starting and ending point of the line segment so let's construct the vector using the same "orientation".

$$\vec{v} = \langle x_2 - x_1, y_2 - y_1, z_2 - z_1 \rangle$$

Using this vector and the point P we get the following vector equation of the line.

$$\vec{r}(t) = \langle x_1, y_1, z_1 \rangle + t \langle x_2 - x_1, y_2 - y_1, z_2 - z_1 \rangle$$

While this is the vector equation of the line, let's rewrite the equation slightly.

$$\begin{aligned} \vec{r}(t) &= \langle x_1, y_1, z_1 \rangle + t \langle x_2, y_2, z_2 \rangle - t \langle x_1, y_1, z_1 \rangle \\ &= (1-t) \langle x_1, y_1, z_1 \rangle + t \langle x_2, y_2, z_2 \rangle \end{aligned}$$

This is the equation of the line that contains the points P and Q . We of course just want the line segment that starts at P and ends at Q . We can get this by simply restricting the values of t .

Notice that

$$\vec{r}(0) = \langle x_1, y_1, z_1 \rangle \qquad \vec{r}(1) = \langle x_2, y_2, z_2 \rangle$$

So, if we restrict t to be between zero and one we will cover the line segment and we will start and end at the correct point.

So the vector equation of the line segment that starts at $P = (x_1, y_1, z_1)$ and ends at

$Q = (x_2, y_2, z_2)$ is,

$$\vec{r}(t) = (1-t) \langle x_1, y_1, z_1 \rangle + t \langle x_2, y_2, z_2 \rangle \qquad 0 \leq t \leq 1$$

As noted briefly at the beginning of this section we can also have vector functions of two variables. In these case the graphs of vector function of two variables are surfaces. So, to make sure that we don't forget that let's work an example with that as well.

Example 8 Identify the surface that is described by $\vec{r}(x, y) = x\vec{i} + y\vec{j} + (x^2 + y^2)\vec{k}$.

Solution

First, notice that in this case the vector function will in fact be a function of two variables. This will always be the case when we are using vector functions to represent surfaces.

To identify the surface let's go back to parametric equations.

$$x = x \qquad y = y \qquad z = x^2 + y^2$$

The first two are really only acknowledging that we are picking x and y for free and then determining z from our choices of these two. The last equation is the one that we want. We should recognize that function from the section on [quadric surfaces](#). The third equation is the equation of an elliptic paraboloid and so the vector function represents an elliptic paraboloid.

As a final topic for this section let's generalize the idea from the previous example and note that given any function of one variable ($y = f(x)$ or $x = h(y)$) or any function of two variables ($z = g(x, y)$, $x = g(y, z)$, or $y = g(x, z)$) we can always write down a vector form of the equation.

For a function of one variable this will be,

$$\vec{r}(x) = x\vec{i} + f(x)\vec{j} \qquad \vec{r}(y) = h(y)\vec{i} + y\vec{j}$$

and for a function of two variables the vector form will be,

$$\vec{r}(x, y) = x\vec{i} + y\vec{j} + g(x, y)\vec{k} \qquad \vec{r}(y, z) = g(y, z)\vec{i} + y\vec{j} + z\vec{k}$$

$$\vec{r}(x, z) = x\vec{i} + g(x, z)\vec{j} + z\vec{k}$$

depending upon the original form of the function.

For example the hyperbolic paraboloid $y = 2x^2 - 5z^2$ can be written as the following vector function.

$$\vec{r}(x, z) = x\vec{i} + (2x^2 - 5z^2)\vec{j} + z\vec{k}$$

This is a fairly important idea and we will be doing quite a bit of this kind of thing in Calculus III.

Calculus with Vector Functions

In this section we need to talk briefly about limits, derivatives and integrals of vector functions. As you will see, these behave in a fairly predictable manner. We will be doing all of the work in \mathbb{R}^3 but we can naturally extend the formulas/work in this section to \mathbb{R}^n (i.e. n -dimensional space).

Let's start with limits. Here is the limit of a vector function.

$$\begin{aligned}\lim_{t \rightarrow a} \vec{r}(t) &= \lim_{t \rightarrow a} \langle f(t), g(t), h(t) \rangle \\ &= \left\langle \lim_{t \rightarrow a} f(t), \lim_{t \rightarrow a} g(t), \lim_{t \rightarrow a} h(t) \right\rangle \\ &= \lim_{t \rightarrow a} f(t) \vec{i} + \lim_{t \rightarrow a} g(t) \vec{j} + \lim_{t \rightarrow a} h(t) \vec{k}\end{aligned}$$

So, all that we do is take the limit of each of the component's functions and leave it as a vector.

Example 1 Compute $\lim_{t \rightarrow 1} \vec{r}(t)$ where $\vec{r}(t) = \left\langle t^3, \frac{\sin(3t-3)}{t-1}, e^{2t} \right\rangle$.

Solution

There really isn't all that much to do here.

$$\begin{aligned}\lim_{t \rightarrow 1} \vec{r}(t) &= \left\langle \lim_{t \rightarrow 1} t^3, \lim_{t \rightarrow 1} \frac{\sin(3t-3)}{t-1}, \lim_{t \rightarrow 1} e^{2t} \right\rangle \\ &= \left\langle \lim_{t \rightarrow 1} t^3, \lim_{t \rightarrow 1} \frac{3 \cos(3t-3)}{1}, \lim_{t \rightarrow 1} e^{2t} \right\rangle \\ &= \langle 1, 3, e^2 \rangle\end{aligned}$$

Notice that we had to use [L'Hospital's Rule](#) on the y component.

Now let's take care of derivatives and after seeing how limits work it shouldn't be too surprising that we have the following for derivatives.

$$\vec{r}'(t) = \langle f'(t), g'(t), h'(t) \rangle = f'(t) \vec{i} + g'(t) \vec{j} + h'(t) \vec{k}$$

Example 2 Compute $\vec{r}'(t)$ for $\vec{r}(t) = t^6 \vec{i} + \sin(2t) \vec{j} - \ln(t+1) \vec{k}$.

Solution

There really isn't too much to this problem other than taking the derivatives.

$$\vec{r}'(t) = 6t^5 \vec{i} + 2 \cos(2t) \vec{j} - \frac{1}{t+1} \vec{k}$$

Most of the basic facts that we know about derivatives still hold however, just to make it clear here are some facts about derivatives of vector functions.

Facts

$$\frac{d}{dt}(\vec{u} + \vec{v}) = \vec{u}' + \vec{v}'$$

$$(c\vec{u})' = c\vec{u}'$$

$$\frac{d}{dt}(f(t)\vec{u}(t)) = f'(t)\vec{u}(t) + f(t)\vec{u}'$$

$$\frac{d}{dt}(\vec{u} \cdot \vec{v}) = \vec{u}' \cdot \vec{v} + \vec{u} \cdot \vec{v}'$$

$$\frac{d}{dt}(\vec{u} \times \vec{v}) = \vec{u}' \times \vec{v} + \vec{u} \times \vec{v}'$$

$$\frac{d}{dt}(\vec{u}(f(t))) = f'(t)\vec{u}'(f(t))$$

There is also one quick definition that we should get out of the way so that we can use it when we need to.

A **smooth curve** is any curve for which $\vec{r}'(t)$ is continuous and $\vec{r}'(t) \neq 0$ for any t except possibly at the endpoints. A helix is a smooth curve, for example.

Finally, we need to discuss integrals of vector functions. Using both limits and derivatives as a guide it shouldn't be too surprising that we also have the following for integration for indefinite integrals

$$\int \vec{r}(t) = \left\langle \int f(t) dt, \int g(t) dt, \int h(t) dt \right\rangle + \vec{c}$$

$$\int \vec{r}(t) = \int f(t) dt \vec{i} + \int g(t) dt \vec{j} + \int h(t) dt \vec{k} + \vec{c}$$

and the following for definite integrals.

$$\int_a^b \vec{r}(t) dt = \left\langle \int_a^b f(t) dt, \int_a^b g(t) dt, \int_a^b h(t) dt \right\rangle$$

$$\int_a^b \vec{r}(t) dt = \int_a^b f(t) dt \vec{i} + \int_a^b g(t) dt \vec{j} + \int_a^b h(t) dt \vec{k}$$

With the indefinite integrals we put in a constant of integration to make sure that it was clear that the constant in this case needs to be a vector instead of a regular constant.

Also, for the definite integrals we will sometimes write it as follows,

$$\int_a^b \vec{r}(t) dt = \left(\left\langle \int_a^b f(t) dt, \int_a^b g(t) dt, \int_a^b h(t) dt \right\rangle \right)_a^b$$

$$\int_a^b \vec{r}(t) dt = \left(\int_a^b f(t) dt \vec{i} + \int_a^b g(t) dt \vec{j} + \int_a^b h(t) dt \vec{k} \right)_a^b$$

In other words, we will do the indefinite integral and then do the evaluation of the vector as a whole instead of on a component by component basis.

Example 3 Compute $\int \vec{r}(t) dt$ for $\vec{r}(t) = \langle \sin(t), 6, 4t \rangle$.

Solution

All we need to do is integrate each of the components and be done with it.

$$\int \vec{r}(t) dt = \langle -\cos(t), 6t, 2t^2 \rangle + \vec{c}$$

Example 4 Compute $\int_0^1 \vec{r}(t) dt$ for $\vec{r}(t) = \langle \sin(t), 6, 4t \rangle$.

Solution

In this case all that we need to do is reuse the result from the previous example and then do the evaluation.

$$\begin{aligned} \int_0^1 \vec{r}(t) dt &= \left(\langle -\cos(t), 6t, 2t^2 \rangle \right)_0^1 \\ &= \langle -\cos(1), 6, 2 \rangle - \langle -1, 0, 0 \rangle \\ &= \langle 1 - \cos(1), 6, 2 \rangle \end{aligned}$$

Tangent, Normal and Binormal Vectors

In this section we want to look at an application of derivatives for vector functions. Actually, there are a couple of applications, but they all come back to needing the first one.

In the past we've used the fact that the derivative of a function was the slope of the tangent line. With vector functions we get exactly the same result, with one exception.

Given the vector function, $\vec{r}(t)$, we call $\vec{r}'(t)$ the **tangent vector** provided it exists and provided $\vec{r}'(t) \neq \vec{0}$. The tangent line to $\vec{r}(t)$ at P is then the line that passes through the point P and is parallel to the tangent vector, $\vec{r}'(t)$. Note that we really do need to require $\vec{r}'(t) \neq \vec{0}$ in order to have a tangent vector. If we had $\vec{r}'(t) = \vec{0}$ we would have a vector that had no magnitude and so couldn't give us the direction of the tangent.

Also, provided $\vec{r}'(t) \neq \vec{0}$, the **unit tangent vector** to the curve is given by,

$$\vec{T}(t) = \frac{\vec{r}'(t)}{\|\vec{r}'(t)\|}$$

While, the components of the unit tangent vector can be somewhat messy on occasion there are times when we will need to use the unit tangent vector instead of the tangent vector.

Example 1 Find the general formula for the tangent vector and unit tangent vector to the curve given by $\vec{r}(t) = t^2 \vec{i} + 2 \sin t \vec{j} + 2 \cos t \vec{k}$.

Solution

First, by general formula we mean that we won't be plugging in a specific t and so we will be finding a formula that we can use at a later date if we'd like to find the tangent at any point on the curve. With that said there really isn't all that much to do at this point other than to do the work.

Here is the tangent vector to the curve.

$$\vec{r}'(t) = 2t \vec{i} + 2 \cos t \vec{j} - 2 \sin t \vec{k}$$

To get the unit tangent vector we need the length of the tangent vector.

$$\begin{aligned} \|\vec{r}'(t)\| &= \sqrt{4t^2 + 4 \cos^2 t + 4 \sin^2 t} \\ &= \sqrt{4t^2 + 4} \end{aligned}$$

The unit tangent vector is then,

$$\begin{aligned} \vec{T}(t) &= \frac{1}{\sqrt{4t^2 + 4}} (2t \vec{i} + 2 \cos t \vec{j} - 2 \sin t \vec{k}) \\ &= \frac{2t}{\sqrt{4t^2 + 4}} \vec{i} + \frac{2 \cos t}{\sqrt{4t^2 + 4}} \vec{j} - \frac{2 \sin t}{\sqrt{4t^2 + 4}} \vec{k} \end{aligned}$$

Example 2 Find the vector equation of the tangent line to the curve given by

$$\vec{r}(t) = t^2 \vec{i} + 2 \sin t \vec{j} + 2 \cos t \vec{k} \text{ at } t = \frac{\pi}{3}.$$

Solution

First we need the tangent vector and since this is the function we were working with in the previous example we can just reuse the tangent vector from that example and plug in $t = \frac{\pi}{3}$.

$$\vec{r}'\left(\frac{\pi}{3}\right) = \frac{2\pi}{3} \vec{i} + 2 \cos\left(\frac{\pi}{3}\right) \vec{j} - 2 \sin\left(\frac{\pi}{3}\right) \vec{k} = \frac{2\pi}{3} \vec{i} + \vec{j} - \sqrt{3} \vec{k}$$

We'll also need the point on the line at $t = \frac{\pi}{3}$ so,

$$\vec{r}\left(\frac{\pi}{3}\right) = \frac{\pi^2}{9} \vec{i} + \sqrt{3} \vec{j} + \vec{k}$$

The vector equation of the line is then,

$$\vec{r}(t) = \left\langle \frac{\pi^2}{9}, \sqrt{3}, 1 \right\rangle + t \left\langle \frac{2\pi}{3}, 1, -\sqrt{3} \right\rangle$$

Before moving on let's note a couple of things about the previous example. First, we could have used the unit tangent vector had we wanted to for the parallel vector. However, that would have made for a more complicated equation for the tangent line.

Second, notice that we used $\vec{r}(t)$ to represent the tangent line despite the fact that we used that as well for the function. Do not get excited about that. The $\vec{r}(t)$ here is much like y is with normal functions. With normal functions, y is the generic letter that we used to represent functions and $\vec{r}(t)$ tends to be used in the same way with vector functions.

Next we need to talk about the **unit normal** and the **binormal** vectors.

The unit normal vector is defined to be,

$$\vec{N}(t) = \frac{\vec{T}'(t)}{\|\vec{T}'(t)\|}$$

The unit normal is orthogonal (or normal, or perpendicular) to the unit tangent vector and hence to the curve as well. We've already seen normal vectors when we were dealing with [Equations of Planes](#). They will show up with some regularity in several Calculus III topics.

The definition of the unit normal vector always seems a little mysterious when you first see it. It follows directly from the following fact.

Fact

Suppose that $\vec{r}(t)$ is a vector such that $\|\vec{r}(t)\| = c$ for all t . Then $\vec{r}'(t)$ is orthogonal to $\vec{r}(t)$.

To prove this fact is pretty simple. From the fact statement and the relationship between the magnitude of a vector and the dot product we have the following.

$$\vec{r}(t) \cdot \vec{r}(t) = \|\vec{r}(t)\|^2 = c^2 \quad \text{for all } t$$

Now, because this is true for all t we can see that,

$$\frac{d}{dt}(\vec{r}(t) \cdot \vec{r}(t)) = \frac{d}{dt}(c^2) = 0$$

Also, recalling the fact from the previous section about differentiating a dot product we see that,

$$\frac{d}{dt}(\vec{r}(t) \cdot \vec{r}(t)) = \vec{r}'(t) \cdot \vec{r}(t) + \vec{r}(t) \cdot \vec{r}'(t) = 2\vec{r}'(t) \cdot \vec{r}(t)$$

Or, upon putting all this together we get,

$$2\vec{r}'(t) \cdot \vec{r}(t) = 0 \quad \Rightarrow \quad \vec{r}'(t) \cdot \vec{r}(t) = 0$$

Therefore $\vec{r}'(t)$ is orthogonal to $\vec{r}(t)$.

The definition of the unit normal then falls directly from this. Because $\vec{T}(t)$ is a unit vector we know that $\|\vec{T}(t)\| = 1$ for all t and hence by the Fact $\vec{T}'(t)$ is orthogonal to $\vec{T}(t)$. However, because $\vec{T}(t)$ is tangent to the curve, $\vec{T}'(t)$ must be orthogonal, or normal, to the curve as well and so be a normal vector for the curve. All we need to do then is divide by $\|\vec{T}'(t)\|$ to arrive at a unit normal vector.

Next, is the binormal vector. The binormal vector is defined to be,

$$\vec{B}(t) = \vec{T}(t) \times \vec{N}(t)$$

Because the binormal vector is defined to be the cross product of the unit tangent and unit normal vector we then know that the binormal vector is orthogonal to both the tangent vector and the normal vector.

Example 3 Find the normal and binormal vectors for $\vec{r}(t) = \langle t, 3 \sin t, 3 \cos t \rangle$.

Solution

We first need the unit tangent vector so first get the tangent vector and its magnitude.

$$\vec{r}'(t) = \langle 1, 3 \cos t, -3 \sin t \rangle$$

$$\|\vec{r}'(t)\| = \sqrt{1 + 9 \cos^2 t + 9 \sin^2 t} = \sqrt{10}$$

The unit tangent vector is then,

$$\vec{T}(t) = \left\langle \frac{1}{\sqrt{10}}, \frac{3}{\sqrt{10}} \cos t, -\frac{3}{\sqrt{10}} \sin t \right\rangle$$

The unit normal vector will now require the derivative of the unit tangent and its magnitude.

$$\vec{T}'(t) = \left\langle 0, -\frac{3}{\sqrt{10}} \sin t, -\frac{3}{\sqrt{10}} \cos t \right\rangle$$

$$\|\vec{T}'(t)\| = \sqrt{\frac{9}{10} \sin^2 t + \frac{9}{10} \cos^2 t} = \sqrt{\frac{9}{10}} = \frac{3}{\sqrt{10}}$$

The unit normal vector is then,

$$\vec{N}(t) = \frac{\sqrt{10}}{3} \left\langle 0, -\frac{3}{\sqrt{10}} \sin t, -\frac{3}{\sqrt{10}} \cos t \right\rangle = \langle 0, -\sin t, -\cos t \rangle$$

Finally, the binormal vector is,

$$\vec{B}(t) = \vec{T}(t) \times \vec{N}(t)$$

$$\begin{aligned} &= \begin{vmatrix} \vec{i} & \vec{j} & \vec{k} \\ \frac{1}{\sqrt{10}} & \frac{3}{\sqrt{10}} \cos t & -\frac{3}{\sqrt{10}} \sin t \\ 0 & -\sin t & -\cos t \end{vmatrix} \begin{vmatrix} \vec{i} & \vec{j} \\ \frac{1}{\sqrt{10}} & \frac{3}{\sqrt{10}} \cos t \\ 0 & -\sin t \end{vmatrix} \\ &= -\frac{3}{\sqrt{10}} \cos^2 t \vec{i} - \frac{1}{\sqrt{10}} \sin t \vec{k} + \frac{1}{\sqrt{10}} \cos t \vec{j} - \frac{3}{\sqrt{10}} \sin^2 t \vec{i} \\ &= -\frac{3}{\sqrt{10}} \vec{i} + \frac{1}{\sqrt{10}} \cos t \vec{j} - \frac{1}{\sqrt{10}} \sin t \vec{k} \end{aligned}$$

Arc Length with Vector Functions

In this section we'll recast an old formula into terms of vector functions. We want to determine the length of a vector function,

$$\vec{r}(t) = \langle f(t), g(t), h(t) \rangle$$

on the interval $a \leq t \leq b$.

We actually already know how to do this. Recall that we can write the vector function into the parametric form,

$$x = f(t) \quad y = g(t) \quad z = h(t)$$

Also, [recall](#) that with two dimensional parametric curves the arc length is given by,

$$L = \int_a^b \sqrt{[f'(t)]^2 + [g'(t)]^2} dt$$

There is a natural extension of this to three dimensions. So, the length of the curve $\vec{r}(t)$ on the interval $a \leq t \leq b$ is,

$$L = \int_a^b \sqrt{[f'(t)]^2 + [g'(t)]^2 + [h'(t)]^2} dt$$

There is a nice simplification that we can make for this. Notice that the integrand (the function we're integrating) is nothing more than the magnitude of the tangent vector,

$$\|\vec{r}'(t)\| = \sqrt{[f'(t)]^2 + [g'(t)]^2 + [h'(t)]^2}$$

Therefore, the arc length can be written as,

$$L = \int_a^b \|\vec{r}'(t)\| dt$$

Let's work a quick example of this.

Example 1 Determine the length of the curve $\vec{r}(t) = \langle 2t, 3 \sin(2t), 3 \cos(2t) \rangle$ on the interval $0 \leq t \leq 2\pi$.

Solution

We will first need the tangent vector and its magnitude.

$$\vec{r}'(t) = \langle 2, 6 \cos(2t), -6 \sin(2t) \rangle$$

$$\|\vec{r}'(t)\| = \sqrt{4 + 36 \cos^2(2t) + 36 \sin^2(2t)} = \sqrt{4 + 36} = 2\sqrt{10}$$

The length is then,

$$\begin{aligned}
 L &= \int_a^b \|\vec{r}'(t)\| dt \\
 &= \int_0^{2\pi} 2\sqrt{10} dt \\
 &= 4\pi\sqrt{10}
 \end{aligned}$$

We need to take a quick look at another concept here. We define the **arc length function** as,

$$s(t) = \int_0^t \|\vec{r}'(u)\| du$$

Before we look at why this might be important let's work a quick example.

Example 2 Determine the arc length function for $\vec{r}(t) = \langle 2t, 3\sin(2t), 3\cos(2t) \rangle$.

Solution

From the previous example we know that,

$$\|\vec{r}'(t)\| = 2\sqrt{10}$$

The arc length function is then,

$$s(t) = \int_0^t 2\sqrt{10} du = (2\sqrt{10}u)'_0 = 2\sqrt{10}t$$

Okay, just why would we want to do this? Well let's take the result of the example above and solve it for t .

$$t = \frac{s}{2\sqrt{10}}$$

Now, taking this and plugging it into the original vector function and we can **reparameterize** the function into the form, $\vec{r}(t(s))$. For our function this is,

$$\vec{r}(t(s)) = \left\langle \frac{s}{\sqrt{10}}, 3\sin\left(\frac{s}{\sqrt{10}}\right), 3\cos\left(\frac{s}{\sqrt{10}}\right) \right\rangle$$

So, why would we want to do this? Well with the reparameterization we can now tell where we are on the curve after we've traveled a distance of s along the curve. Note as well that we will start the measurement of distance from where we are at $t = 0$.

Example 3 Where on the curve $\vec{r}(t) = \langle 2t, 3\sin(2t), 3\cos(2t) \rangle$ are we after traveling for a distance of $\frac{\pi\sqrt{10}}{3}$?

Solution

To determine this we need the reparameterization, which we have from above.

$$\vec{r}(t(s)) = \left\langle \frac{s}{\sqrt{10}}, 3 \sin\left(\frac{s}{\sqrt{10}}\right), 3 \cos\left(\frac{s}{\sqrt{10}}\right) \right\rangle$$

Then, to determine where we are all that we need to do is plug in $s = \frac{\pi\sqrt{10}}{3}$ into this and we'll get our location.

$$\vec{r}\left(t\left(\frac{\pi\sqrt{10}}{3}\right)\right) = \left\langle \frac{\pi}{3}, 3 \sin\left(\frac{\pi}{3}\right), 3 \cos\left(\frac{\pi}{3}\right) \right\rangle = \left\langle \frac{\pi}{3}, \frac{3\sqrt{3}}{2}, \frac{3}{2} \right\rangle$$

So, after traveling a distance of $\frac{\pi\sqrt{10}}{3}$ along the curve we are at the point $\left(\frac{\pi}{3}, \frac{3\sqrt{3}}{2}, \frac{3}{2}\right)$.

Curvature

In this section we want to briefly discuss the **curvature** of a smooth curve (recall that for a smooth curve we require $\vec{r}'(t)$ is continuous and $\vec{r}'(t) \neq 0$). The curvature measures how fast a curve is changing direction at a given point.

There are several formulas for determining the curvature for a curve. The formal definition of curvature is,

$$\kappa = \left| \frac{d\vec{T}}{ds} \right|$$

where \vec{T} is the unit tangent and s is the arc length. Recall that we saw in a [previous section](#) how to reparameterize a curve to get it into terms of the arc length.

In general the formal definition of the curvature is not easy to use so there are two alternate formulas that we can use. Here they are.

$$\kappa = \frac{\|\vec{T}'(t)\|}{\|\vec{r}'(t)\|} \qquad \kappa = \frac{\|\vec{r}'(t) \times \vec{r}''(t)\|}{\|\vec{r}'(t)\|^3}$$

These may not be particularly easy to deal with either, but at least we don't need to reparameterize the unit tangent.

Example 1 Determine the curvature for $\vec{r}(t) = \langle t, 3 \sin t, 3 \cos t \rangle$.

Solution

Back in the [section](#) when we introduced the tangent vector we computed the tangent and unit tangent vectors for this function. These were,

$$\begin{aligned} \vec{r}'(t) &= \langle 1, 3 \cos t, -3 \sin t \rangle \\ \vec{T}(t) &= \left\langle \frac{1}{\sqrt{10}}, \frac{3}{\sqrt{10}} \cos t, -\frac{3}{\sqrt{10}} \sin t \right\rangle \end{aligned}$$

The derivative of the unit tangent is,

$$\vec{T}'(t) = \left\langle 0, -\frac{3}{\sqrt{10}} \sin t, -\frac{3}{\sqrt{10}} \cos t \right\rangle$$

The magnitudes of the two vectors are,

$$\begin{aligned} \|\vec{r}'(t)\| &= \sqrt{1 + 9 \cos^2 t + 9 \sin^2 t} = \sqrt{10} \\ \|\vec{T}'(t)\| &= \sqrt{0 + \frac{9}{10} \sin^2 t + \frac{9}{10} \cos^2 t} = \sqrt{\frac{9}{10}} = \frac{3}{\sqrt{10}} \end{aligned}$$

The curvature is then,

$$\kappa = \frac{\|\vec{T}'(t)\|}{\|\vec{r}'(t)\|} = \frac{3/\sqrt{10}}{\sqrt{10}} = \frac{3}{10}$$

In this case the curvature is constant. This means that the curve is changing direction at the same rate at every point along it. Recalling that this curve is a helix this result makes sense.

Example 2 Determine the curvature of $\vec{r}(t) = t^2 \vec{i} + t \vec{k}$.

Solution

In this case the second form of the curvature would probably be easiest. Here are the first couple of derivatives.

$$\vec{r}'(t) = 2t \vec{i} + \vec{k} \quad \vec{r}''(t) = 2 \vec{i}$$

Next, we need the cross product.

$$\begin{aligned} \vec{r}'(t) \times \vec{r}''(t) &= \begin{vmatrix} \vec{i} & \vec{j} & \vec{k} \\ 2t & 0 & 1 \\ 2 & 0 & 0 \end{vmatrix} = \begin{vmatrix} \vec{i} & \vec{j} \\ 2t & 0 \\ 2 & 0 \end{vmatrix} \\ &= 2 \vec{j} \end{aligned}$$

The magnitudes are,

$$\|\vec{r}'(t) \times \vec{r}''(t)\| = 2 \quad \|\vec{r}'(t)\| = \sqrt{4t^2 + 1}$$

The curvature at any value of t is then,

$$\kappa = \frac{2}{(4t^2 + 1)^{\frac{3}{2}}}$$

There is a special case that we can look at here as well. Suppose that we have a curve given by $y = f(x)$ and we want to find its curvature.

As we saw when we first looked at [vector functions](#) we can write this as follows,

$$\vec{r}(x) = x \vec{i} + f(x) \vec{j}$$

If we then use the second formula for the curvature we will arrive at the following formula for the curvature.

$$\kappa = \frac{|f''(x)|}{(1 + [f'(x)]^2)^{\frac{3}{2}}}$$

Velocity and Acceleration

In this section we need to take a look at the velocity and acceleration of a moving object.

From Calculus I we know that given the position function of an object that the velocity of the object is the first derivative of the position function and the acceleration of the object is the second derivative of the position function.

So, given this it shouldn't be too surprising that if the position function of an object is given by the vector function $\vec{r}(t)$ then the velocity and acceleration of the object is given by,

$$\vec{v}(t) = \vec{r}'(t) \qquad \vec{a}(t) = \vec{r}''(t)$$

Notice that the velocity and acceleration are also going to be vectors as well.

In the study of the motion of objects the acceleration is often broken up into a **tangential component**, a_T , and a **normal component**, a_N . The tangential component is the part of the acceleration that is tangential to the curve and the normal component is the part of the acceleration that is normal (or orthogonal) to the curve. If we do this we can write the acceleration as,

$$\vec{a} = a_T \vec{T} + a_N \vec{N}$$

where \vec{T} and \vec{N} are the unit tangent and unit normal for the position function.

If we define $v = \|\vec{v}(t)\|$ then the tangential and normal components of the acceleration are given by,

$$a_T = v' = \frac{\vec{r}'(t) \cdot \vec{r}''(t)}{\|\vec{r}'(t)\|} \qquad a_N = \kappa v^2 = \frac{\|\vec{r}'(t) \times \vec{r}''(t)\|}{\|\vec{r}'(t)\|^3}$$

where κ is the [curvature](#) for the position function.

There are two formulas to use here for each component of the acceleration and while the second formula may seem overly complicated it is often the easier of the two. In the tangential component, v , may be messy and computing the derivative may be unpleasant. In the normal component we will already be computing both of these quantities in order to get the curvature and so the second formula in this case is definitely the easier of the two.

Let's take a quick look at a couple of examples.

Example 1 If the acceleration of an object is given by $\vec{a} = \vec{i} + 2\vec{j} + 6t\vec{k}$ find the object's velocity and position functions given that the initial velocity is $\vec{v}(0) = \vec{j} - \vec{k}$ and the initial position is $\vec{r}(0) = \vec{i} - 2\vec{j} + 3\vec{k}$.

Solution

We'll first get the velocity. To do this all (well almost all) we need to do is integrate the acceleration.

$$\begin{aligned}\vec{v}(t) &= \int \vec{a}(t) dt \\ &= \int \vec{i} + 2\vec{j} + 6t\vec{k} dt \\ &= t\vec{i} + 2t\vec{j} + 3t^2\vec{k} + \vec{c}\end{aligned}$$

To completely get the velocity we will need to determine the “constant” of integration. We can use the initial velocity to get this.

$$\vec{j} - \vec{k} = \vec{v}(0) = \vec{c}$$

The velocity of the object is then,

$$\begin{aligned}\vec{v}(t) &= t\vec{i} + 2t\vec{j} + 3t^2\vec{k} + \vec{j} - \vec{k} \\ &= t\vec{i} + (2t+1)\vec{j} + (3t^2-1)\vec{k}\end{aligned}$$

We will find the position function by integrating the velocity function.

$$\begin{aligned}\vec{r}(t) &= \int \vec{v}(t) dt \\ &= \int t\vec{i} + (2t+1)\vec{j} + (3t^2-1)\vec{k} dt \\ &= \frac{1}{2}t^2\vec{i} + (t^2+t)\vec{j} + (t^3-t)\vec{k} + \vec{c}\end{aligned}$$

Using the initial position gives us,

$$\vec{i} - 2\vec{j} + 3\vec{k} = \vec{r}(0) = \vec{c}$$

So, the position function is,

$$\vec{r}(t) = \left(\frac{1}{2}t^2 + 1\right)\vec{i} + (t^2 + t - 2)\vec{j} + (t^3 - t + 3)\vec{k}$$

Example 2 For the object in the previous example determine the tangential and normal components of the acceleration.

Solution

There really isn't much to do here other than plug into the formulas. To do this we'll need to notice that,

$$\begin{aligned}\vec{r}'(t) &= t\vec{i} + (2t+1)\vec{j} + (3t^2-1)\vec{k} \\ \vec{r}''(t) &= \vec{i} + 2\vec{j} + 6t\vec{k}\end{aligned}$$

Let's first compute the dot product and cross product that we'll need for the formulas.

$$\vec{r}'(t) \cdot \vec{r}''(t) = t + 2(2t+1) + 6t(3t^2-1) = 18t^3 - t + 2$$

$$\begin{aligned}\vec{r}'(t) \times \vec{r}''(t) &= \begin{vmatrix} \vec{i} & \vec{j} & \vec{k} \\ t & 2t+1 & 3t^2-1 \\ 1 & 2 & 6t \end{vmatrix} \begin{vmatrix} \vec{i} & \vec{j} \\ t & 2t+1 \\ 1 & 2 \end{vmatrix} \\ &= (6t)(2t+1)\vec{i} + (3t^2-1)\vec{j} + 2t\vec{k} - 6t^2\vec{j} - 2(3t^2-1)\vec{i} - (2t+1)\vec{k} \\ &= (6t^2+6t+2)\vec{i} - (3t^2+1)\vec{j} - \vec{k}\end{aligned}$$

Next, we also need a couple of magnitudes.

$$\|\vec{r}'(t)\| = \sqrt{t^2 + (2t+1)^2 + (3t^2-1)^2} = \sqrt{9t^4 - t^2 + 4t + 2}$$

$$\|\vec{r}'(t) \times \vec{r}''(t)\| = \sqrt{(6t^2+6t+2)^2 + (3t^2+1)^2 + 1} = \sqrt{45t^4 + 72t^3 + 66t^2 + 24t + 6}$$

The tangential component of the acceleration is then,

$$a_T = \frac{18t^3 - t + 2}{\sqrt{9t^4 - t^2 + 4t + 2}}$$

The normal component of the acceleration is,

$$a_N = \frac{\sqrt{45t^4 + 72t^3 + 66t^2 + 24t + 6}}{\sqrt{9t^4 - t^2 + 4t + 2}} = \sqrt{\frac{45t^4 + 72t^3 + 66t^2 + 24t + 6}{9t^4 - t^2 + 4t + 2}}$$

Cylindrical Coordinates

As with two dimensional space the standard (x, y, z) coordinate system is called the Cartesian coordinate system. In the last two sections of this chapter we'll be looking at some alternate coordinate systems for three dimensional space.

We'll start off with the cylindrical coordinate system. This one is fairly simple as it is nothing more than an extension of [polar coordinates](#) into three dimensions. Not only is it an extension of polar coordinates, but we extend it into the third dimension just as we extend Cartesian coordinates into the third dimension. All that we do is add a z on as the third coordinate. The r and θ are the same as with polar coordinates.

Here is a sketch of a point in \mathbb{R}^3 .

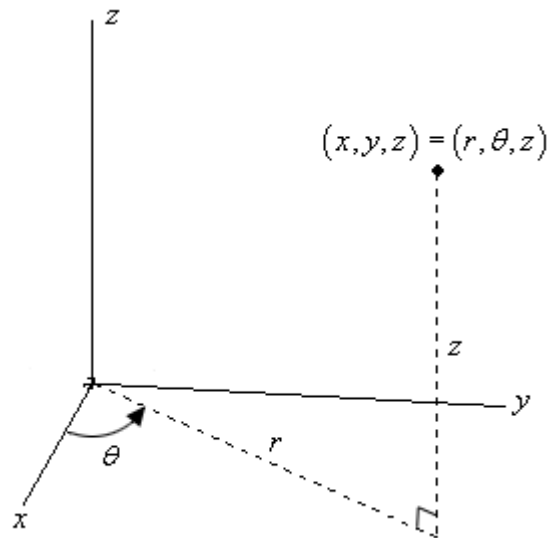

The conversions for x and y are the same conversions that we used back when we were looking at polar coordinates. So, if we have a point in cylindrical coordinates the Cartesian coordinates can be found by using the following conversions.

$$x = r \cos \theta$$

$$y = r \sin \theta$$

$$z = z$$

The third equation is just an acknowledgement that the z -coordinate of a point in Cartesian and polar coordinates is the same.

Likewise, if we have a point in Cartesian coordinates the cylindrical coordinates can be found by using the following conversions.

$$r = \sqrt{x^2 + y^2} \quad \text{OR} \quad r^2 = x^2 + y^2$$

$$\theta = \tan^{-1}\left(\frac{y}{x}\right)$$

$$z = z$$

Let's take a quick look at some surfaces in cylindrical coordinates.

Example 1 Identify the surface for each of the following equations.

(a) $r = 5$

(b) $r^2 + z^2 = 100$

(c) $z = r$

Solution

(a) In two dimensions we know that this is a circle of radius 5. Since we are now in three dimensions and there is no z in equation this means it is allowed to vary freely. So, for any given z we will have a circle of radius 5 centered on the z -axis.

In other words, we will have a cylinder of radius 5 centered on the z -axis.

(b) This equation will be easy to identify once we convert back to Cartesian coordinates.

$$r^2 + z^2 = 100$$

$$x^2 + y^2 + z^2 = 100$$

So, this is a sphere centered at the origin with radius 10.

(c) Again, this one won't be too bad if we convert back to Cartesian. For reasons that will be apparent eventually, we'll first square both sides, then convert.

$$z^2 = r^2$$

$$z^2 = x^2 + y^2$$

From the section on [quadric surfaces](#) we know that this is the equation of a cone.

Spherical Coordinates

In this section we will introduce spherical coordinates. Spherical coordinates can take a little getting used to. It's probably easiest to start things off with a sketch.

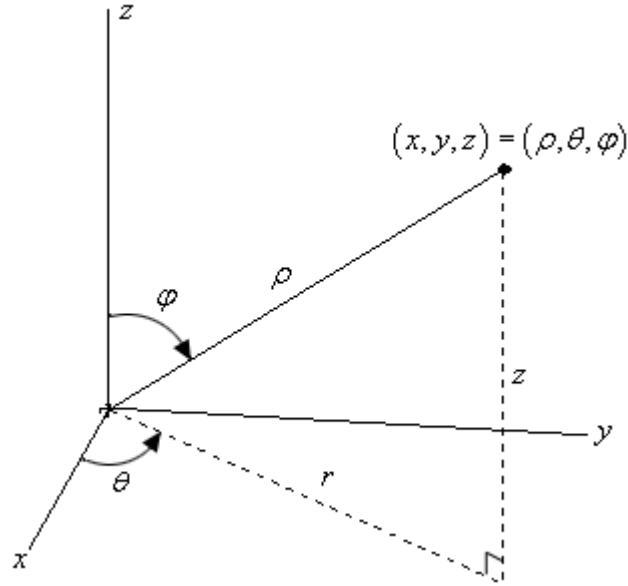

Spherical coordinates consist of the following three quantities.

First there is ρ . This is the distance from the origin to the point and we will require $\rho \geq 0$.

Next there is θ . This is the same angle that we saw in polar/cylindrical coordinates. It is the angle between the positive x -axis and the line above denoted by r (which is also the same r as in polar/cylindrical coordinates). There are no restrictions on θ .

Finally there is φ . This is the angle between the positive z -axis and the line from the origin to the point. We will require $0 \leq \varphi \leq \pi$.

In summary, ρ is the distance from the origin to the point, φ is the angle that we need to rotate down from the positive z -axis to get to the point and θ is how much we need to rotate around the z -axis to get to the point.

We should first derive some conversion formulas. Let's first start with a point in spherical coordinates and ask what the cylindrical coordinates of the point are. So, we know (ρ, θ, φ) and want to find (r, θ, z) . Of course we really only need to find r and z since θ is the same in both coordinate systems.

We will be able to do all of our work by looking at the right triangle shown above in our sketch. With a little geometry we see that the angle between z and ρ is φ and so we can see that,

$$z = \rho \cos \varphi$$

$$r = \rho \sin \varphi$$

and these are exactly the formulas that we were looking for. So, given a point in spherical coordinates the cylindrical coordinates of the point will be,

$$r = \rho \sin \varphi$$

$$\theta = \theta$$

$$z = \rho \cos \varphi$$

Note as well that,

$$r^2 + z^2 = \rho^2 \cos^2 \varphi + \rho^2 \sin^2 \varphi = \rho^2 (\cos^2 \varphi + \sin^2 \varphi) = \rho^2$$

Or,

$$\rho^2 = r^2 + z^2$$

Next, let's find the Cartesian coordinates of the same point. To do this we'll start with the cylindrical conversion formulas from the [previous section](#).

$$x = r \cos \theta$$

$$y = r \sin \theta$$

$$z = z$$

Now all that we need to do is use the formulas from above for r and z to get,

$$x = \rho \sin \varphi \cos \theta$$

$$y = \rho \sin \varphi \sin \theta$$

$$z = \rho \cos \varphi$$

Also note that since we know that $r^2 = x^2 + y^2$ we get,

$$\rho^2 = x^2 + y^2 + z^2$$

Converting points from Cartesian or cylindrical coordinates into spherical coordinates is usually done with the same conversion formulas. To see how this is done let's work an example of each.

Example 1 Perform each of the following conversions.

(a) Convert the point $\left(\sqrt{6}, \frac{\pi}{4}, \sqrt{2}\right)$ from cylindrical to spherical coordinates.

[\[Solution\]](#)

(b) Convert the point $(-1, 1, -\sqrt{2})$ from Cartesian to spherical coordinates.

[\[Solution\]](#)

Solution

(a) Convert the point $\left(\sqrt{6}, \frac{\pi}{4}, \sqrt{2}\right)$ from cylindrical to spherical coordinates.

We'll start by acknowledging that θ is the same in both coordinate systems and so we don't need to do anything with that.

Next, let's find ρ .

$$\rho = \sqrt{r^2 + z^2} = \sqrt{6 + 2} = \sqrt{8} = 2\sqrt{2}$$

Finally, let's get φ . To do this we can use either the conversion for r or z . We'll use the conversion for z .

$$z = \rho \cos \varphi \quad \Rightarrow \quad \cos \varphi = \frac{z}{\rho} = \frac{\sqrt{2}}{2\sqrt{2}} \quad \Rightarrow \quad \varphi = \cos^{-1}\left(\frac{1}{2}\right) = \frac{\pi}{3}$$

Notice that there are many possible values of φ that will give $\cos \varphi = \frac{1}{2}$, however, we have restricted φ to the range $0 \leq \varphi \leq \pi$ and so this is the only possible value in that range.

So, the spherical coordinates of this point will be $\left(2\sqrt{2}, \frac{\pi}{4}, \frac{\pi}{3}\right)$.

[\[Return to Problems\]](#)

(b) Convert the point $(-1, 1, -\sqrt{2})$ from Cartesian to spherical coordinates.

The first thing that we'll do here is find ρ .

$$\rho = \sqrt{x^2 + y^2 + z^2} = \sqrt{1 + 1 + 2} = 2$$

Now we'll need to find φ . We can do this using the conversion for z .

$$z = \rho \cos \varphi \quad \Rightarrow \quad \cos \varphi = \frac{z}{\rho} = \frac{-\sqrt{2}}{2} \quad \Rightarrow \quad \varphi = \cos^{-1}\left(\frac{-\sqrt{2}}{2}\right) = \frac{3\pi}{4}$$

As with the last parts this will be the only possible φ in the range allowed.

Finally, let's find θ . To do this we can use the conversion for x or y . We will use the conversion for y in this case.

$$\sin \theta = \frac{y}{\rho \sin \varphi} = \frac{1}{2\left(\frac{\sqrt{2}}{2}\right)} = \frac{1}{\sqrt{2}} = \frac{\sqrt{2}}{2} \quad \Rightarrow \quad \theta = \frac{\pi}{4} \text{ or } \theta = \frac{3\pi}{4}$$

Now, we actually have more possible choices for θ but all of them will reduce down to one of the two angles above since they will just be one of these two angles with one or more complete rotations around the unit circle added on.

We will however, need to decide which one is the correct angle since only one will be. To do

this let's notice that, in two dimensions, the point with coordinates $x = -1$ and $y = 1$ lies in the second quadrant. This means that θ must be angle that will put the point into the second quadrant. Therefore, the second angle, $\theta = \frac{3\pi}{4}$, must be the correct one.

The spherical coordinates of this point are then $\left(2, \frac{3\pi}{4}, \frac{3\pi}{4}\right)$.

[\[Return to Problems\]](#)

Now, let's take a look at some equations and identify the surfaces that they represent.

Example 2 Identify the surface for each of the following equations.

(a) $\rho = 5$ [\[Solution\]](#)

(b) $\varphi = \frac{\pi}{3}$ [\[Solution\]](#)

(c) $\theta = \frac{2\pi}{3}$ [\[Solution\]](#)

(d) $\rho \sin \varphi = 2$ [\[Solution\]](#)

Solution

(a) $\rho = 5$

There are a couple of ways to think about this one.

First, think about what this equation is saying. This equation says that, no matter what θ and φ are, the distance from the origin must be 5. So, we can rotate as much as we want away from the z -axis and around the z -axis, but we must always remain at a fixed distance from the origin. This is exactly what a sphere is. So, this is a sphere of radius 5 centered at the origin.

The other way to think about it is to just convert to Cartesian coordinates.

$$\begin{aligned}\rho &= 5 \\ \rho^2 &= 25 \\ x^2 + y^2 + z^2 &= 25\end{aligned}$$

Sure enough a sphere of radius 5 centered at the origin.

[\[Return to Problems\]](#)

(b) $\varphi = \frac{\pi}{3}$

In this case there isn't an easy way to convert to Cartesian coordinates so we'll just need to think about this one a little. This equation says that no matter how far away from the origin that we move and no matter how much we rotate around the z -axis the point must always be at an angle of $\frac{\pi}{3}$ from the z -axis.

This is exactly what happens in a cone. All of the points on a cone are a fixed angle from the z -

axis. So, we have a cone whose points are all at an angle of $\frac{\pi}{3}$ from the z -axis.

[\[Return to Problems\]](#)

$$(c) \theta = \frac{2\pi}{3}$$

As with the last part we won't be able to easily convert to Cartesian coordinates here. In this case no matter how far from the origin we get or how much we rotate down from the positive z -axis the points must always form an angle of $\frac{2\pi}{3}$ with the x -axis.

Points in a vertical plane will do this. So, we have a vertical plane that forms an angle of $\frac{2\pi}{3}$ with the positive x -axis.

[\[Return to Problems\]](#)

$$(d) \rho \sin \varphi = 2$$

In this case we can convert to Cartesian coordinates so let's do that. There are actually two ways to do this conversion. We will look at both since both will be used on occasion.

Solution 1

In this solution method we will convert directly to Cartesian coordinates. To do this we will first need to square both sides of the equation.

$$\rho^2 \sin^2 \varphi = 4$$

Now, for no apparent reason add $\rho^2 \cos^2 \varphi$ to both sides.

$$\rho^2 \sin^2 \varphi + \rho^2 \cos^2 \varphi = 4 + \rho^2 \cos^2 \varphi$$

$$\rho^2 (\sin^2 \varphi + \cos^2 \varphi) = 4 + \rho^2 \cos^2 \varphi$$

$$\rho^2 = 4 + (\rho \cos \varphi)^2$$

Now we can convert to Cartesian coordinates.

$$x^2 + y^2 + z^2 = 4 + z^2$$

$$x^2 + y^2 = 4$$

So, we have a cylinder of radius 2 centered on the z -axis.

This solution method wasn't too bad, but it did require some not so obvious steps to complete.

Solution 2

This method is much shorter, but also involves something that you may not see the first time around. In this case instead of going straight to Cartesian coordinates we'll first convert to cylindrical coordinates.

This won't always work, but in this case all we need to do is recognize that $r = \rho \sin \varphi$ and we will get something we can recognize. Using this we get,

$$\rho \sin \varphi = 2$$

$$r = 2$$

At this point we know this is a cylinder (remember that we're in three dimensions and so this isn't a circle!). However, let's go ahead and finish the conversion process out.

$$r^2 = 4$$

$$x^2 + y^2 = 4$$

[\[Return to Problems\]](#)

So, as we saw in the last part of the previous example it will *sometimes* be easier to convert equations in spherical coordinates into cylindrical coordinates before converting into Cartesian coordinates. This won't always be easier, but it can make some of the conversions quicker and easier.

The last thing that we want to do in this section is generalize the first three parts of the previous example.

| | |
|--------------------|--|
| $\rho = a$ | sphere of radius a centered at the origin |
| $\varphi = \alpha$ | cone that makes an angle of α with the positive z – axis |
| $\theta = \beta$ | vertical plane that makes an angle of β with the positive x – axis |

Partial Derivatives

Introduction

In Calculus I and in most of Calculus II we concentrated on functions of one variable. In Calculus III we will extend our knowledge of calculus into functions of two or more variables. Despite the fact that this chapter is about derivatives we will start out the chapter with a section on limits of functions of more than one variable. In the remainder of this chapter we will be looking at differentiating functions of more than one variable. As we will see, while there are differences with derivatives of functions of one variable, if you can do derivatives of functions of one variable you shouldn't have any problems differentiating functions of more than one variable.

Here is a list of topics in this chapter.

Limits – Taking limits of functions of several variables.

Partial Derivatives – In this section we will introduce the idea of partial derivatives as well as the standard notations and how to compute them.

Interpretations of Partial Derivatives – Here we will take a look at a couple of important interpretations of partial derivatives.

Higher Order Partial Derivatives – We will take a look at higher order partial derivatives in this section.

Differentials – In this section we extend the idea of differentials to functions of several variables.

Chain Rule – Here we will look at the chain rule for functions of several variables.

Directional Derivatives – We will introduce the concept of directional derivatives in this section. We will also see how to compute them and see a couple of nice facts pertaining to directional derivatives.

Limits

In this section we will take a look at limits involving functions of more than one variable. In fact, we will concentrate mostly on limits of functions of two variables, but the ideas can be extended out to functions with more than two variables.

Before getting into this let's briefly recall how limits of functions of one variable work. We say that,

$$\lim_{x \rightarrow a} f(x) = L$$

provided,

$$\lim_{x \rightarrow a^+} f(x) = \lim_{x \rightarrow a^-} f(x) = L$$

Also, recall that,

$$\lim_{x \rightarrow a^+} f(x)$$

is a right hand limit and requires us to only look at values of x that are greater than a . Likewise,

$$\lim_{x \rightarrow a^-} f(x)$$

is a left hand limit and requires us to only look at values of x that are less than a .

In other words, we will have $\lim_{x \rightarrow a} f(x) = L$ provided $f(x)$ approaches L as we move in towards $x = a$ (without letting $x = a$) from both sides.

Now, notice that in this case there are only two paths that we can take as we move in towards $x = a$. We can either move in from the left or we can move in from the right. Then in order for the limit of a function of one variable to exist the function must be approaching the same value as we take each of these paths in towards $x = a$.

With functions of two variables we will have to do something similar, except this time there is (potentially) going to be a lot more work involved. Let's first address the notation and get a feel for just what we're going to be asking for in these kinds of limits.

We will be asking to take the limit of the function $f(x, y)$ as x approaches a and as y approaches b . This can be written in several ways. Here are a couple of the more standard notations.

$$\lim_{\substack{x \rightarrow a \\ y \rightarrow b}} f(x, y) \qquad \lim_{(x, y) \rightarrow (a, b)} f(x, y)$$

We will use the second notation more often than not in this course. The second notation is also a little more helpful in illustrating what we are really doing here when we are taking a limit. In taking a limit of a function of two variables we are really asking what the value of $f(x, y)$ is doing as we move the point (x, y) in closer and closer to the point (a, b) without actually letting it be (a, b) .

Just like with limits of functions of one variable, in order for this limit to exist, the function must be approaching the same value regardless of the path that we take as we move in towards (a, b) . The problem that we are immediately faced with is that there are literally an infinite number of paths that we can take as we move in towards (a, b) . Here are a few examples of paths that we could take.

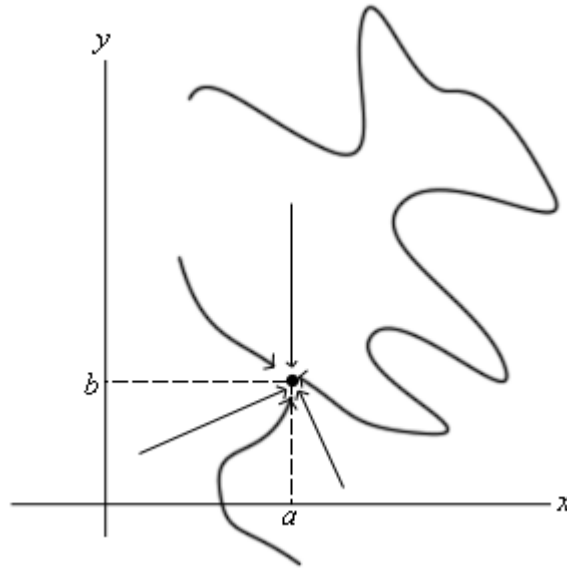

We put in a couple of straight line paths as well as a couple of “stranger” paths that aren’t straight line paths. Also, we only included 6 paths here and as you can see simply by varying the slope of the straight line paths there are an infinite number of these and then we would need to consider paths that aren’t straight line paths.

In other words, to show that a limit exists we would technically need to check an infinite number of paths and verify that the function is approaching the same value regardless of the path we are using to approach the point.

Luckily for us however we can use one of the main ideas from Calculus I limits to help us take limits here.

Definition

A function $f(x, y)$ is **continuous** at the point (a, b) if,

$$\lim_{(x,y) \rightarrow (a,b)} f(x, y) = f(a, b)$$

From a graphical standpoint this definition means the same thing as it did when we first saw [continuity](#) in Calculus I. A function will be continuous at a point if the graph doesn’t have any holes or breaks at that point.

How can this help us take limits? Well, just as in Calculus I, if you know that a function is continuous at (a, b) then you also know that

$$\lim_{(x,y) \rightarrow (a,b)} f(x, y) = f(a, b)$$

must be true. So, if we know that a function is continuous at a point then all we need to do to take the limit of the function at that point is to plug the point into the function.

All the standard functions that we know to be continuous are still continuous even if we are plugging in more than one variable now. We just need to watch out for division by zero, square roots of negative numbers, logarithms of zero or negative numbers, *etc.*

Note that the idea about paths is one that we shouldn't forget since it is a nice way to determine if a limit doesn't exist. If we can find two paths upon which the function approaches different values as we get near the point then we will know that the limit doesn't exist.

Let's take a look at a couple of examples.

Example 1 Determine if the following limits exist or not. If they do exist give the value of the limit.

(a) $\lim_{(x,y,z) \rightarrow (2,1,-1)} 3x^2z + yx \cos(\pi x - \pi z)$ [[Solution](#)]

(b) $\lim_{(x,y) \rightarrow (5,1)} \frac{xy}{x+y}$ [[Solution](#)]

(c) $\lim_{(x,y) \rightarrow (0,0)} \frac{x^2y^2}{x^4 + 3y^4}$ [[Solution](#)]

(d) $\lim_{(x,y) \rightarrow (0,0)} \frac{x^3y}{x^6 + y^2}$ [[Solution](#)]

Solution

(a) $\lim_{(x,y,z) \rightarrow (2,1,-1)} 3x^2z + yx \cos(\pi x - \pi z)$

Okay, in this case the function is continuous at the point in question and so all we need to do is plug in the values and we're done.

$$\lim_{(x,y,z) \rightarrow (2,1,-1)} 3x^2z + yx \cos(\pi x - \pi z) = 3(2)^2(-1) + (1)(2) \cos(2\pi + \pi) = -14$$

[[Return to Problems](#)]

(b) $\lim_{(x,y) \rightarrow (5,1)} \frac{xy}{x+y}$

In this case the function will not be continuous along the line $y = -x$ since we will get division by zero when this is true. However, for this problem that is not something that we will need to worry about since the point that we are taking the limit at isn't on this line.

Therefore, all that we need to do is plug in the point since the function is continuous at this point.

$$\lim_{(x,y) \rightarrow (5,1)} \frac{xy}{x+y} = \frac{5}{6}$$

[[Return to Problems](#)]

$$(c) \lim_{(x,y) \rightarrow (0,0)} \frac{x^2 y^2}{x^4 + 3y^4}$$

Now, in this case the function is not continuous at the point in question and so we can't just plug in the point. So, since the function is not continuous at the point there is at least a chance that the limit doesn't exist. If we could find two different paths to approach the point that gave different values for the limit then we would know that the limit didn't exist. Two of the more common paths to check are the x and y -axis so let's try those.

Before actually doing this we need to address just what exactly do we mean when we say that we are going to approach a point along a path. When we approach a point along a path we will do this by either fixing x or y or by relating x and y through some function. In this way we can reduce the limit to just a limit involving a single variable which we know how to do from Calculus I.

So, let's see what happens along the x -axis. If we are going to approach $(0,0)$ along the x -axis we can take advantage of the fact that along the x -axis we know that $y = 0$. This means that, along the x -axis, we will plug in $y = 0$ into the function and then take the limit as x approaches zero.

$$\lim_{(x,y) \rightarrow (0,0)} \frac{x^2 y^2}{x^4 + 3y^4} = \lim_{(x,0) \rightarrow (0,0)} \frac{x^2 (0)^2}{x^4 + 3(0)^4} = \lim_{(x,0) \rightarrow (0,0)} 0 = 0$$

So, along the x -axis the function will approach zero as we move in towards the origin.

Now, let's try the y -axis. Along this axis we have $x = 0$ and so the limit becomes,

$$\lim_{(x,y) \rightarrow (0,0)} \frac{x^2 y^2}{x^4 + 3y^4} = \lim_{(0,y) \rightarrow (0,0)} \frac{(0)^2 y^2}{(0)^4 + 3y^4} = \lim_{(0,y) \rightarrow (0,0)} 0 = 0$$

So, the same limit along two paths. Don't misread this. This does NOT say that the limit exists and has a value of zero. This only means that the limit happens to have the same value along two paths.

Let's take a look at a third fairly common path to take a look at. In this case we'll move in towards the origin along the path $y = x$. This is what we meant previously about relating x and y through a function.

To do this we will replace all the y 's with x 's and then let x approach zero. Let's take a look at this limit.

$$\lim_{(x,y) \rightarrow (0,0)} \frac{x^2 y^2}{x^4 + 3y^4} = \lim_{(x,x) \rightarrow (0,0)} \frac{x^2 x^2}{x^4 + 3x^4} = \lim_{(x,x) \rightarrow (0,0)} \frac{x^4}{4x^4} = \lim_{(x,x) \rightarrow (0,0)} \frac{1}{4} = \frac{1}{4}$$

So, a different value from the previous two paths and this means that the limit can't possibly exist.

Note that we can use this idea of moving in towards the origin along a line with the more general

path $y = mx$ if we need to.

[\[Return to Problems\]](#)

$$(d) \lim_{(x,y) \rightarrow (0,0)} \frac{x^3 y}{x^6 + y^2}$$

Okay, with this last one we again have continuity problems at the origin. So, again let's see if we can find a couple of paths that give different values of the limit.

First, we will use the path $y = x$. Along this path we have,

$$\lim_{(x,y) \rightarrow (0,0)} \frac{x^3 y}{x^6 + y^2} = \lim_{(x,x) \rightarrow (0,0)} \frac{x^3 x}{x^6 + x^2} = \lim_{(x,x) \rightarrow (0,0)} \frac{x^4}{x^6 + x^2} = \lim_{(x,x) \rightarrow (0,0)} \frac{x^2}{x^4 + 1} = 0$$

Now, let's try the path $y = x^3$. Along this path the limit becomes,

$$\lim_{(x,y) \rightarrow (0,0)} \frac{x^3 y}{x^6 + y^2} = \lim_{(x,x^3) \rightarrow (0,0)} \frac{x^3 x^3}{x^6 + (x^3)^2} = \lim_{(x,x^3) \rightarrow (0,0)} \frac{x^6}{2x^6} = \lim_{(x,x^3) \rightarrow (0,0)} \frac{1}{2} = \frac{1}{2}$$

We now have two paths that give different values for the limit and so the limit doesn't exist.

As this limit has shown us we can, and often need, to use paths other than lines.

[\[Return to Problems\]](#)

Partial Derivatives

Now that we have the brief discussion on limits out of the way we can proceed into taking derivatives of functions of more than one variable. Before we actually start taking derivatives of functions of more than one variable let's recall an important interpretation of derivatives of functions of one variable.

Recall that given a function of one variable, $f(x)$, the derivative, $f'(x)$, represents the rate of change of the function as x changes. This is an important interpretation of derivatives and we are not going to want to lose it with functions of more than one variable. The problem with functions of more than one variable is that there is more than one variable. In other words, what do we do if we only want one of the variables to change, or if we want more than one of them to change? In fact, if we're going to allow more than one of the variables to change there are then going to be an infinite amount of ways for them to change. For instance, one variable could be changing faster than the other variable(s) in the function. Notice as well that it will be completely possible for the function to be changing differently depending on how we allow one or more of the variables to change.

We will need to develop ways, and notations, for dealing with all of these cases. In this section we are going to concentrate exclusively on only changing one of the variables at a time, while the remaining variable(s) are held fixed. We will deal with allowing multiple variables to change in a later [section](#).

Because we are going to only allow one of the variables to change taking the derivative will now become a fairly simple process. Let's start off this discussion with a fairly simple function.

Let's start with the function $f(x, y) = 2x^2y^3$ and let's determine the rate at which the function is changing at a point, (a, b) , if we hold y fixed and allow x to vary and if we hold x fixed and allow y to vary.

We'll start by looking at the case of holding y fixed and allowing x to vary. Since we are interested in the rate of change of the function at (a, b) and are holding y fixed this means that we are going to always have $y = b$ (if we didn't have this then eventually y would have to change in order to get to the point...). Doing this will give us a function involving only x 's and we can define a new function as follows,

$$g(x) = f(x, b) = 2x^2b^3$$

Now, this is a function of a single variable and at this point all that we are asking is to determine the rate of change of $g(x)$ at $x = a$. In other words, we want to compute $g'(a)$ and since this is a function of a single variable we already know how to do that. Here is the rate of change of the function at (a, b) if we hold y fixed and allow x to vary.

$$g'(a) = 4ab^3$$

We will call $g'(a)$ the **partial derivative** of $f(x, y)$ with respect to x at (a, b) and we will denote it in the following way,

$$f_x(a, b) = 4ab^3$$

Now, let's do it the other way. We will now hold x fixed and allow y to vary. We can do this in a similar way. Since we are holding x fixed it must be fixed at $x = a$ and so we can define a new function of y and then differentiate this as we've always done with functions of one variable.

Here is the work for this,

$$h(y) = f(a, y) = 2a^2y^3 \quad \Rightarrow \quad h'(y) = 6a^2y^2$$

In this case we call $h'(y)$ the **partial derivative** of $f(x, y)$ with respect to y at (a, b) and we denote it as follows,

$$f_y(a, b) = 6a^2b^2$$

Note that these two partial derivatives are sometimes called the **first order partial derivatives**. Just as with functions of one variable we can have derivatives of all orders. We will be looking at higher order derivatives in a later [section](#).

Note that the notation for partial derivatives is different than that for derivatives of functions of a single variable. With functions of a single variable we could denote the derivative with a single prime. However, with partial derivatives we will always need to remember the variable that we are differentiating with respect to and so we will subscript the variable that we differentiated with respect to. We will shortly be seeing some alternate notation for partial derivatives as well.

Note as well that we usually don't use the (a, b) notation for partial derivatives. The more standard notation is to just continue to use (x, y) . So, the partial derivatives from above will more commonly be written as,

$$f_x(x, y) = 4xy^3 \quad \text{and} \quad f_y(x, y) = 6x^2y^2$$

Now, as this quick example has shown taking derivatives of functions of more than one variable is done in pretty much the same manner as taking derivatives of a single variable. To compute $f_x(x, y)$ all we need to do is treat all the y 's as constants (or numbers) and then differentiate the x 's as we've always done. Likewise, to compute $f_y(x, y)$ we will treat all the x 's as constants and then differentiate the y 's as we are used to doing.

Before we work any examples let's get the formal definition of the partial derivative out of the way as well as some alternate notation.

Since we can think of the two partial derivatives above as derivatives of single variable functions it shouldn't be too surprising that the definition of each is very similar to the definition of the derivative for single variable functions. Here are the formal definitions of the two partial derivatives we looked at above.

$$f_x(x, y) = \lim_{h \rightarrow 0} \frac{f(x+h, y) - f(x, y)}{h} \qquad f_y(x, y) = \lim_{h \rightarrow 0} \frac{f(x, y+h) - f(x, y)}{h}$$

Now let's take a quick look at some of the possible alternate notations for partial derivatives. Given the function $z = f(x, y)$ the following are all equivalent notations,

$$f_x(x, y) = f_x = \frac{\partial f}{\partial x} = \frac{\partial}{\partial x}(f(x, y)) = z_x = \frac{\partial z}{\partial x} = D_x f$$

$$f_y(x, y) = f_y = \frac{\partial f}{\partial y} = \frac{\partial}{\partial y}(f(x, y)) = z_y = \frac{\partial z}{\partial y} = D_y f$$

For the fractional notation for the partial derivative notice the difference between the partial derivative and the ordinary derivative from single variable calculus.

$$f(x) \quad \Rightarrow \quad f'(x) = \frac{df}{dx}$$

$$f(x, y) \quad \Rightarrow \quad f_x(x, y) = \frac{\partial f}{\partial x} \quad \& \quad f_y(x, y) = \frac{\partial f}{\partial y}$$

Okay, now let's work some examples. When working these examples always keep in mind that we need to pay very close attention to which variable we are differentiating with respect to. This is important because we are going to treat all other variables as constants and then proceed with the derivative as if it was a function of a single variable. If you can remember this you'll find that doing partial derivatives are not much more difficult than doing derivatives of functions of a single variable as we did in Calculus I.

Example 1 Find all of the first order partial derivatives for the following functions.

(a) $f(x, y) = x^4 + 6\sqrt{y} - 10$ [Solution]

(b) $w = x^2y - 10y^2z^3 + 43x - 7 \tan(4y)$ [Solution]

(c) $h(s, t) = t^7 \ln(s^2) + \frac{9}{t^3} - \sqrt[3]{s^4}$ [Solution]

(d) $f(x, y) = \cos\left(\frac{4}{x}\right) e^{x^2y-5y^3}$ [Solution]

Solution

(a) $f(x, y) = x^4 + 6\sqrt{y} - 10$

Let's first take the derivative with respect to x and remember that as we do so all the y 's will be treated as constants. The partial derivative with respect to x is,

$$f_x(x, y) = 4x^3$$

Notice that the second and the third term differentiate to zero in this case. It should be clear why the third term differentiated to zero. It's a constant and we know that constants always differentiate to zero. This is also the reason that the second term differentiated to zero.

Remember that since we are differentiating with respect to x here we are going to treat all y 's as constants. That means that terms that only involve y 's will be treated as constants and hence will

differentiate to zero.

Now, let's take the derivative with respect to y . In this case we treat all x 's as constants and so the first term involves only x 's and so will differentiate to zero, just as the third term will. Here is the partial derivative with respect to y .

$$f_y(x, y) = \frac{3}{\sqrt{y}}$$

[\[Return to Problems\]](#)

(b) $w = x^2y - 10y^2z^3 + 43x - 7 \tan(4y)$

With this function we've got three first order derivatives to compute. Let's do the partial derivative with respect to x first. Since we are differentiating with respect to x we will treat all y 's and all z 's as constants. This means that the second and fourth terms will differentiate to zero since they only involve y 's and z 's.

This first term contains both x 's and y 's and so when we differentiate with respect to x the y will be thought of as a multiplicative constant and so the first term will be differentiated just as the third term will be differentiated.

Here is the partial derivative with respect to x .

$$\frac{\partial w}{\partial x} = 2xy + 43$$

Let's now differentiate with respect to y . In this case all x 's and z 's will be treated as constants. This means the third term will differentiate to zero since it contains only x 's while the x 's in the first term and the z 's in the second term will be treated as multiplicative constants. Here is the derivative with respect to y .

$$\frac{\partial w}{\partial y} = x^2 - 20yz^3 - 28 \sec^2(4y)$$

Finally, let's get the derivative with respect to z . Since only one of the terms involve z 's this will be the only non-zero term in the derivative. Also, the y 's in that term will be treated as multiplicative constants. Here is the derivative with respect to z .

$$\frac{\partial w}{\partial z} = -30y^2z^2$$

[\[Return to Problems\]](#)

(c) $h(s, t) = t^7 \ln(s^2) + \frac{9}{t^3} - \sqrt[7]{s^4}$

With this one we'll not put in the detail of the first two. Before taking the derivative let's rewrite the function a little to help us with the differentiation process.

$$h(s, t) = t^7 \ln(s^2) + 9t^{-3} - s^{\frac{4}{7}}$$

Now, the fact that we're using s and t here instead of the "standard" x and y shouldn't be a problem. It will work the same way. Here are the two derivatives for this function.

$$h_s(s, t) = \frac{\partial h}{\partial s} = t^7 \left(\frac{2s}{s^2} \right) - \frac{4}{7} s^{-\frac{3}{7}} = \frac{2t^7}{s} - \frac{4}{7} s^{-\frac{3}{7}}$$

$$h_t(s, t) = \frac{\partial h}{\partial t} = 7t^6 \ln(s^2) - 27t^{-4}$$

Remember how to differentiate natural logarithms.

$$\frac{d}{dx}(\ln g(x)) = \frac{g'(x)}{g(x)}$$

[\[Return to Problems\]](#)

(d) $f(x, y) = \cos\left(\frac{4}{x}\right) e^{x^2y-5y^3}$

Now, we can't forget the product rule with derivatives. The product rule will work the same way here as it does with functions of one variable. We will just need to be careful to remember which variable we are differentiating with respect to.

Let's start out by differentiating with respect to x . In this case both the cosine and the exponential contain x 's and so we've really got a product of two functions involving x 's and so we'll need to product rule this up. Here is the derivative with respect to x .

$$\begin{aligned} f_x(x, y) &= -\sin\left(\frac{4}{x}\right) \left(-\frac{4}{x^2}\right) e^{x^2y-5y^3} + \cos\left(\frac{4}{x}\right) e^{x^2y-5y^3} (2xy) \\ &= \frac{4}{x^2} \sin\left(\frac{4}{x}\right) e^{x^2y-5y^3} + 2xy \cos\left(\frac{4}{x}\right) e^{x^2y-5y^3} \end{aligned}$$

Do not forget the [chain rule](#) for functions of one variable. We will be looking at the chain rule for some more complicated expressions for multivariable functions in a later section. However, at this point we're treating all the y 's as constants and so the chain rule will continue to work as it did back in Calculus I.

Also, don't forget how to differentiate exponential functions,

$$\frac{d}{dx}(e^{f(x)}) = f'(x) e^{f(x)}$$

Now, let's differentiate with respect to y . In this case we don't have a product rule to worry about since the only place that the y shows up is in the exponential. Therefore, since x 's are considered to be constants for this derivative, the cosine in the front will also be thought of as a multiplicative constant. Here is the derivative with respect to y .

$$f_y(x, y) = (x^2 - 15y^2) \cos\left(\frac{4}{x}\right) e^{x^2y-5y^3}$$

[\[Return to Problems\]](#)

Example 2 Find all of the first order partial derivatives for the following functions.

(a) $z = \frac{9u}{u^2 + 5v}$ [[Solution](#)]

(b) $g(x, y, z) = \frac{x \sin(y)}{z^2}$ [[Solution](#)]

(c) $z = \sqrt{x^2 + \ln(5x - 3y^2)}$ [[Solution](#)]

Solution

(a) $z = \frac{9u}{u^2 + 5v}$

We also can't forget about the quotient rule. Since there isn't too much to this one, we will simply give the derivatives.

$$z_u = \frac{9(u^2 + 5v) - 9u(2u)}{(u^2 + 5v)^2} = \frac{-9u^2 + 45v}{(u^2 + 5v)^2}$$

$$z_v = \frac{(0)(u^2 + 5v) - 9u(5)}{(u^2 + 5v)^2} = \frac{-45u}{(u^2 + 5v)^2}$$

In the case of the derivative with respect to v recall that u 's are constant and so when we differentiate the numerator we will get zero!

[\[Return to Problems\]](#)

(b) $g(x, y, z) = \frac{x \sin(y)}{z^2}$

Now, we do need to be careful however to not use the quotient rule when it doesn't need to be used. In this case we do have a quotient, however, since the x 's and y 's only appear in the numerator and the z 's only appear in the denominator this really isn't a quotient rule problem.

Let's do the derivatives with respect to x and y first. In both these cases the z 's are constants and so the denominator in this is a constant and so we don't really need to worry too much about it. Here are the derivatives for these two cases.

$$g_x(x, y, z) = \frac{\sin(y)}{z^2} \qquad g_y(x, y, z) = \frac{x \cos(y)}{z^2}$$

Now, in the case of differentiation with respect to z we can avoid the quotient rule with a quick rewrite of the function. Here is the rewrite as well as the derivative with respect to z .

$$g(x, y, z) = x \sin(y) z^{-2}$$

$$g_z(x, y, z) = -2x \sin(y) z^{-3} = -\frac{2x \sin(y)}{z^3}$$

We went ahead and put the derivative back into the "original" form just so we could say that we did. In practice you probably don't really need to do that.

[\[Return to Problems\]](#)

$$(c) z = \sqrt{x^2 + \ln(5x - 3y^2)}$$

In this last part we are just going to do a somewhat messy chain rule problem. However, if you had a good background in [Calculus I chain rule](#) this shouldn't be all that difficult of a problem. Here are the two derivatives,

$$\begin{aligned} z_x &= \frac{1}{2}(x^2 + \ln(5x - 3y^2))^{-\frac{1}{2}} \frac{\partial}{\partial x}(x^2 + \ln(5x - 3y^2)) \\ &= \frac{1}{2}(x^2 + \ln(5x - 3y^2))^{-\frac{1}{2}} \left(2x + \frac{5}{5x - 3y^2}\right) \\ &= \left(x + \frac{5}{2(5x - 3y^2)}\right) (x^2 + \ln(5x - 3y^2))^{-\frac{1}{2}} \\ z_y &= \frac{1}{2}(x^2 + \ln(5x - 3y^2))^{-\frac{1}{2}} \frac{\partial}{\partial y}(x^2 + \ln(5x - 3y^2)) \\ &= \frac{1}{2}(x^2 + \ln(5x - 3y^2))^{-\frac{1}{2}} \left(\frac{-6y}{5x - 3y^2}\right) \\ &= -\frac{3y}{5x - 3y^2} (x^2 + \ln(5x - 3y^2))^{-\frac{1}{2}} \end{aligned}$$

[\[Return to Problems\]](#)

So, there are some examples of partial derivatives. Hopefully you will agree that as long as we can remember to treat the other variables as constants these work in exactly the same manner that derivatives of functions of one variable do. So, if you can do Calculus I derivatives you shouldn't have too much difficulty in doing basic partial derivatives.

There is one final topic that we need to take a quick look at in this section, implicit differentiation. Before getting into implicit differentiation for multiple variable functions let's first remember how implicit differentiation works for functions of one variable.

Example 3 Find $\frac{dy}{dx}$ for $3y^4 + x^7 = 5x$.

Solution

Remember that the key to this is to always think of y as a function of x , or $y = y(x)$ and so whenever we differentiate a term involving y 's with respect to x we will really need to use the chain rule which will mean that we will add on a $\frac{dy}{dx}$ to that term.

The first step is to differentiate both sides with respect to x .

$$12y^3 \frac{dy}{dx} + 7x^6 = 5$$

The final step is to solve for $\frac{dy}{dx}$.

$$\frac{dy}{dx} = \frac{5-7x^6}{12y^3}$$

Now, we did this problem because implicit differentiation works in exactly the same manner with functions of multiple variables. If we have a function in terms of three variables $x, y,$ and z we will assume that z is in fact a function of x and y . In other words, $z = z(x, y)$. Then whenever we differentiate z 's with respect to x we will use the chain rule and add on a $\frac{\partial z}{\partial x}$. Likewise, whenever we differentiate z 's with respect to y we will add on a $\frac{\partial z}{\partial y}$.

Let's take a quick look at a couple of implicit differentiation problems.

Example 4 Find $\frac{\partial z}{\partial x}$ and $\frac{\partial z}{\partial y}$ for each of the following functions.

(a) $x^3z^2 - 5xy^5z = x^2 + y^3$ [Solution]

(b) $x^2 \sin(2y - 5z) = 1 + y \cos(6zx)$ [Solution]

Solution

(a) $x^3z^2 - 5xy^5z = x^2 + y^3$

Let's start with finding $\frac{\partial z}{\partial x}$. We first will differentiate both sides with respect to x and remember

to add on a $\frac{\partial z}{\partial x}$ whenever we differentiate a z .

$$3x^2z^2 + 2x^3z \frac{\partial z}{\partial x} - 5y^5z - 5xy^5 \frac{\partial z}{\partial x} = 2x$$

Remember that since we are assuming $z = z(x, y)$ then any product of x 's and z 's will be a product and so will need the product rule!

Now, solve for $\frac{\partial z}{\partial x}$.

$$\begin{aligned} (2x^3z - 5xy^5) \frac{\partial z}{\partial x} &= 2x - 3x^2z^2 + 5y^5z \\ \frac{\partial z}{\partial x} &= \frac{2x - 3x^2z^2 + 5y^5z}{2x^3z - 5xy^5} \end{aligned}$$

Now we'll do the same thing for $\frac{\partial z}{\partial y}$ except this time we'll need to remember to add on a $\frac{\partial z}{\partial y}$ whenever we differentiate a z .

$$2x^3z \frac{\partial z}{\partial y} - 25xy^4z - 5xy^5 \frac{\partial z}{\partial y} = 3y^2$$

$$(2x^3z - 5xy^5) \frac{\partial z}{\partial y} = 3y^2 + 25xy^4z$$

$$\frac{\partial z}{\partial y} = \frac{3y^2 + 25xy^4z}{2x^3z - 5xy^5}$$

[\[Return to Problems\]](#)

(b) $x^2 \sin(2y - 5z) = 1 + y \cos(6zx)$

We'll do the same thing for this function as we did in the previous part. First let's find $\frac{\partial z}{\partial x}$.

$$2x \sin(2y - 5z) + x^2 \cos(2y - 5z) \left(-5 \frac{\partial z}{\partial x} \right) = -y \sin(6zx) \left(6z + 6x \frac{\partial z}{\partial x} \right)$$

Don't forget to do the chain rule on each of the trig functions and when we are differentiating the inside function on the cosine we will need to also use the product rule. Now let's solve for $\frac{\partial z}{\partial x}$.

$$2x \sin(2y - 5z) - 5 \frac{\partial z}{\partial x} x^2 \cos(2y - 5z) = -6zy \sin(6zx) - 6yx \sin(6zx) \frac{\partial z}{\partial x}$$

$$2x \sin(2y - 5z) + 6zy \sin(6zx) = \left(5x^2 \cos(2y - 5z) - 6yx \sin(6zx) \right) \frac{\partial z}{\partial x}$$

$$\frac{\partial z}{\partial x} = \frac{2x \sin(2y - 5z) + 6zy \sin(6zx)}{5x^2 \cos(2y - 5z) - 6yx \sin(6zx)}$$

Now let's take care of $\frac{\partial z}{\partial y}$. This one will be slightly easier than the first one.

$$x^2 \cos(2y - 5z) \left(2 - 5 \frac{\partial z}{\partial y} \right) = \cos(6zx) - y \sin(6zx) \left(6x \frac{\partial z}{\partial y} \right)$$

$$2x^2 \cos(2y - 5z) - 5x^2 \cos(2y - 5z) \frac{\partial z}{\partial y} = \cos(6zx) - 6xy \sin(6zx) \frac{\partial z}{\partial y}$$

$$\left(6xy \sin(6zx) - 5x^2 \cos(2y - 5z) \right) \frac{\partial z}{\partial y} = \cos(6zx) - 2x^2 \cos(2y - 5z)$$

$$\frac{\partial z}{\partial y} = \frac{\cos(6zx) - 2x^2 \cos(2y - 5z)}{6xy \sin(6zx) - 5x^2 \cos(2y - 5z)}$$

[\[Return to Problems\]](#)

There's quite a bit of work to these. We will see an easier way to do implicit differentiation in a later [section](#).

Interpretations of Partial Derivatives

This is a fairly short section and is here so we can acknowledge that the two main interpretations of derivatives of functions of a single variable still hold for partial derivatives, with small modifications of course to account of the fact that we now have more than one variable.

The first interpretation we've already seen and is the more important of the two. As with functions of single variables partial derivatives represent the rates of change of the functions as the variables change. As we saw in the previous section, $f_x(x, y)$ represents the rate of change of the function $f(x, y)$ as we change x and hold y fixed while $f_y(x, y)$ represents the rate of change of $f(x, y)$ as we change y and hold x fixed.

Example 1 Determine if $f(x, y) = \frac{x^2}{y^3}$ is increasing or decreasing at $(2, 5)$,

- (a) if we allow x to vary and hold y fixed.
- (b) if we allow y to vary and hold x fixed.

Solution

(a) If we allow x to vary and hold y fixed.

In this case we will first need $f_x(x, y)$ and its value at the point.

$$f_x(x, y) = \frac{2x}{y^3} \quad \Rightarrow \quad f_x(2, 5) = \frac{4}{125} > 0$$

So, the partial derivative with respect to x is positive and so if we hold y fixed the function is increasing at $(2, 5)$ as we vary x .

(b) If we allow y to vary and hold x fixed.

For this part we will need $f_y(x, y)$ and its value at the point.

$$f_y(x, y) = -\frac{3x^2}{y^4} \quad \Rightarrow \quad f_y(2, 5) = -\frac{12}{625} < 0$$

Here the partial derivative with respect to y is negative and so the function is decreasing at $(2, 5)$ as we vary y and hold x fixed.

Note that it is completely possible for a function to be increasing for a fixed y and decreasing for a fixed x at a point as this example has shown. To see a nice example of this take a look at the following graph.

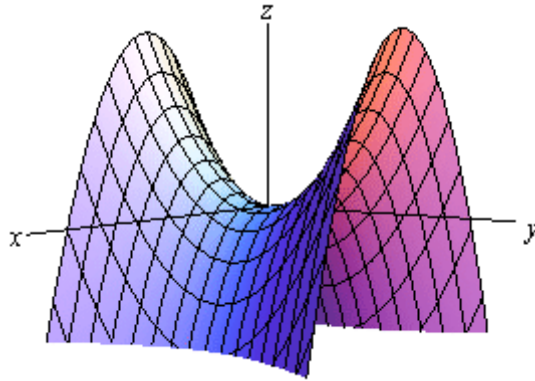

This is a graph of a [hyperbolic paraboloid](#) and at the origin we can see that if we move in along the y -axis the graph is increasing and if we move along the x -axis the graph is decreasing. So it is completely possible to have a graph both increasing and decreasing at a point depending upon the direction that we move. We should never expect that the function will behave in exactly the same way at a point as each variable changes.

The next interpretation was one of the standard interpretations in a Calculus I class. We know from a Calculus I class that $f'(a)$ represents the slope of the tangent line to $y = f(x)$ at $x = a$. Well, $f_x(a, b)$ and $f_y(a, b)$ also represent the slopes of tangent lines. The difference here is the functions that they represent tangent lines to.

Partial derivatives are the slopes of [traces](#). The partial derivative $f_x(a, b)$ is the slope of the trace of $f(x, y)$ for the plane $y = b$ at the point (a, b) . Likewise the partial derivative $f_y(a, b)$ is the slope of the trace of $f(x, y)$ for the plane $x = a$ at the point (a, b) .

Example 2 Find the slopes of the traces to $z = 10 - 4x^2 - y^2$ at the point $(1, 2)$.

Solution

We sketched the traces for the planes $x = 1$ and $y = 2$ in a previous [section](#) and these are the two traces for this point. For reference purposes here are the graphs of the traces.

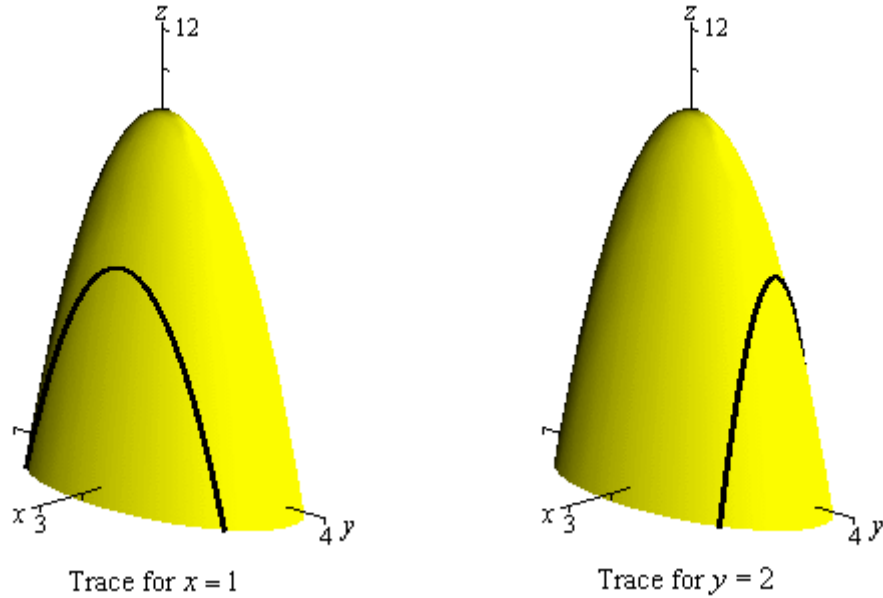

Next we'll need the two partial derivatives so we can get the slopes.

$$f_x(x, y) = -8x \qquad f_y(x, y) = -2y$$

To get the slopes all we need to do is evaluate the partial derivatives at the point in question.

$$f_x(1, 2) = -8 \qquad f_y(1, 2) = -4$$

So, the tangent line at $(1, 2)$ for the trace to $z = 10 - 4x^2 - y^2$ for the plane $y = 2$ has a slope of -8 . Also the tangent line at $(1, 2)$ for the trace to $z = 10 - 4x^2 - y^2$ for the plane $x = 1$ has a slope of -4 .

Finally, let's briefly talk about getting the equations of the tangent line. Recall that the [equation of a line](#) in 3-D space is given by a vector equation. Also to get the equation we need a point on the line and a vector that is parallel to the line.

The point is easy. Since we know the x - y coordinates of the point all we need to do is plug this into the equation to get the point. So, the point will be,

$$(a, b, f(a, b))$$

The parallel (or tangent) vector is also just as easy. We can write the equation of the surface as a vector function as follows,

$$\vec{r}(x, y) = \langle x, y, z \rangle = \langle x, y, f(x, y) \rangle$$

We [know](#) that if we have a vector function of one variable we can get a tangent vector by differentiating the vector function. The same will hold true here. If we differentiate with respect to x we will get a tangent vector to traces for the plane $y = b$ (*i.e.* for fixed y) and if we differentiate with respect to y we will get a tangent vector to traces for the plane $x = a$ (or fixed x).

So, here is the tangent vector for traces with fixed y .

$$\vec{r}_x(x, y) = \langle 1, 0, f_x(x, y) \rangle$$

We differentiated each component with respect to x . Therefore the first component becomes a 1 and the second becomes a zero because we are treating y as a constant when we differentiate with respect to x . The third component is just the partial derivative of the function with respect to x .

For traces with fixed x the tangent vector is,

$$\vec{r}_y(x, y) = \langle 0, 1, f_y(x, y) \rangle$$

The equation for the tangent line to traces with fixed y is then,

$$\vec{r}(t) = \langle a, b, f(a, b) \rangle + t \langle 1, 0, f_x(a, b) \rangle$$

and the tangent line to traces with fixed x is,

$$\vec{r}(t) = \langle a, b, f(a, b) \rangle + t \langle 0, 1, f_y(a, b) \rangle$$

Example 3 Write down the vector equations of the tangent lines to the traces to $z = 10 - 4x^2 - y^2$ at the point $(1, 2)$.

Solution

There really isn't all that much to do with these other than plugging the values and function into the formulas above. We've already computed the derivatives and their values at $(1, 2)$ in the previous example and the point on each trace is,

$$(1, 2, f(1, 2)) = (1, 2, 2)$$

Here is the equation of the tangent line to the trace for the plane $y = 2$.

$$\vec{r}(t) = \langle 1, 2, 2 \rangle + t \langle 1, 0, -8 \rangle = \langle 1+t, 2, 2-8t \rangle$$

Here is the equation of the tangent line to the trace for the plane $x = 1$.

$$\vec{r}(t) = \langle 1, 2, 2 \rangle + t \langle 0, 1, -4 \rangle = \langle 1, 2+t, 2-4t \rangle$$

Higher Order Partial Derivatives

Just as we had higher order derivatives with functions of one variable we will also have higher order derivatives of functions of more than one variable. However, this time we will have more options since we do have more than one variable..

Consider the case of a function of two variables, $f(x, y)$ since both of the first order partial derivatives are also functions of x and y we could in turn differentiate each with respect to x or y . This means that for the case of a function of two variables there will be a total of four possible second order derivatives. Here they are and the notations that we'll use to denote them.

$$(f_x)_x = f_{xx} = \frac{\partial}{\partial x} \left(\frac{\partial f}{\partial x} \right) = \frac{\partial^2 f}{\partial x^2}$$

$$(f_x)_y = f_{xy} = \frac{\partial}{\partial y} \left(\frac{\partial f}{\partial x} \right) = \frac{\partial^2 f}{\partial y \partial x}$$

$$(f_y)_x = f_{yx} = \frac{\partial}{\partial x} \left(\frac{\partial f}{\partial y} \right) = \frac{\partial^2 f}{\partial x \partial y}$$

$$(f_y)_y = f_{yy} = \frac{\partial}{\partial y} \left(\frac{\partial f}{\partial y} \right) = \frac{\partial^2 f}{\partial y^2}$$

The second and third second order partial derivatives are often called mixed partial derivatives since we are taking derivatives with respect to more than one variable. Note as well that the order that we take the derivatives in is given by the notation for each these. If we are using the subscripting notation, e.g. f_{xy} , then we will differentiate from left to right. In other words, in this case, we will differentiate first with respect to x and then with respect to y . With the fractional notation, e.g. $\frac{\partial^2 f}{\partial y \partial x}$, it is the opposite. In these cases we differentiate moving along the denominator from right to left. So, again, in this case we differentiate with respect to x first and then y .

Let's take a quick look at an example.

Example 1 Find all the second order derivatives for $f(x, y) = \cos(2x) - x^2 e^{5y} + 3y^2$.

Solution

We'll first need the first order derivatives so here they are.

$$f_x(x, y) = -2 \sin(2x) - 2xe^{5y}$$

$$f_y(x, y) = -5x^2 e^{5y} + 6y$$

Now, let's get the second order derivatives.

$$f_{xx} = -4 \cos(2x) - 2e^{5y}$$

$$f_{xy} = -10xe^{5y}$$

$$f_{yx} = -10xe^{5y}$$

$$f_{yy} = -25x^2e^{5y} + 6$$

Notice that we dropped the (x, y) from the derivatives. This is fairly standard and we will be doing it most of the time from this point on. We will also be dropping it for the first order derivatives in most cases.

Now let's also notice that, in this case, $f_{xy} = f_{yx}$. This is not by coincidence. If the function is "nice enough" this will always be the case. So, what's "nice enough"? The following theorem tells us.

Clairaut's Theorem

Suppose that f is defined on a disk D that contains the point (a, b) . If the functions f_{xy} and f_{yx} are continuous on this disk then,

$$f_{xy}(a, b) = f_{yx}(a, b)$$

Now, do not get too excited about the disk business and the fact that we gave the theorem for a specific point. In pretty much every example in this class if the two mixed second order partial derivatives are continuous then they will be equal.

Example 2 Verify Clairaut's Theorem for $f(x, y) = xe^{-x^2y^2}$.

Solution

We'll first need the two first order derivatives.

$$f_x(x, y) = e^{-x^2y^2} - 2x^2y^2e^{-x^2y^2}$$

$$f_y(x, y) = -2yx^3e^{-x^2y^2}$$

Now, compute the two mixed second order partial derivatives.

$$f_{xy}(x, y) = -2yx^2e^{-x^2y^2} - 4x^2ye^{-x^2y^2} + 4x^4y^3e^{-x^2y^2} = -6x^2ye^{-x^2y^2} + 4x^4y^3e^{-x^2y^2}$$

$$f_{yx}(x, y) = -6yx^2e^{-x^2y^2} + 4y^3x^4e^{-x^2y^2}$$

Sure enough they are the same.

So far we have only looked at second order derivatives. There are, of course, higher order derivatives as well. Here are a couple of the third order partial derivatives of function of two variables.

$$f_{xyx} = (f_{xy})_x = \frac{\partial}{\partial x} \left(\frac{\partial^2 f}{\partial y \partial x} \right) = \frac{\partial^3 f}{\partial x \partial y \partial x}$$

$$f_{yxx} = (f_{yx})_x = \frac{\partial}{\partial x} \left(\frac{\partial^2 f}{\partial x \partial y} \right) = \frac{\partial^3 f}{\partial x^2 \partial y}$$

Notice as well that for both of these we differentiate once with respect to y and twice with respect to x . There is also another third order partial derivative in which we can do this, f_{xxy} . There is an extension to Clairaut's Theorem that says if all three of these are continuous then they should all be equal,

$$f_{xxy} = f_{xyx} = f_{yxx}$$

To this point we've only looked at functions of two variables, but everything that we've done to this point will work regardless of the number of variables that we've got in the function and there are natural extensions to Clairaut's theorem to all of these cases as well. For instance,

$$f_{xz}(x, y, z) = f_{zx}(x, y, z)$$

provided both of the derivatives are continuous.

In general, we can extend Clairaut's theorem to any function and mixed partial derivatives. The only requirement is that in each derivative we differentiate with respect to each variable the same number of times. In other words, provided we meet the continuity condition, the following will be equal

$$f_{ssrtsrr} = f_{trsrssr}$$

because in each case we differentiate with respect to t once, s three times and r three times.

Let's do a couple of examples with higher (well higher order than two anyway) order derivatives and functions of more than two variables.

Example 3 Find the indicated derivative for each of the following functions.

(a) Find f_{xxyyzz} for $f(x, y, z) = z^3 y^2 \ln(x)$ [Solution]

(b) Find $\frac{\partial^3 f}{\partial y \partial x^2}$ for $f(x, y) = e^{xy}$ [Solution]

Solution

(a) Find f_{xxyyzz} for $f(x, y, z) = z^3 y^2 \ln(x)$

In this case remember that we differentiate from left to right. Here are the derivatives for this part.

$$f_x = \frac{z^3 y^2}{x}$$

$$f_{xx} = -\frac{z^3 y^2}{x^2}$$

$$f_{xxy} = -\frac{2z^3 y}{x^2}$$

$$f_{xxyz} = -\frac{6z^2y}{x^2}$$

$$f_{xyzz} = -\frac{12zy}{x^2}$$

[\[Return to Problems\]](#)

(b) Find $\frac{\partial^3 f}{\partial y \partial x^2}$ for $f(x, y) = e^{xy}$

Here we differentiate from right to left. Here are the derivatives for this function.

$$\frac{\partial f}{\partial x} = ye^{xy}$$

$$\frac{\partial^2 f}{\partial x^2} = y^2 e^{xy}$$

$$\frac{\partial^3 f}{\partial y \partial x^2} = 2ye^{xy} + xy^2 e^{xy}$$

[\[Return to Problems\]](#)

Differentials

This is a very short section and is here simply to acknowledge that just like we had [differentials](#) for functions of one variable we also have them for functions of more than one variable. Also, as we've already seen in previous sections, when we move up to more than one variable things work pretty much the same, but there are some small differences.

Given the function $z = f(x, y)$ the differential dz or df is given by,

$$dz = f_x dx + f_y dy \quad \text{or} \quad df = f_x dx + f_y dy$$

There is a natural extension to functions of three or more variables. For instance, given the function $w = g(x, y, z)$ the differential is given by,

$$dw = g_x dx + g_y dy + g_z dz$$

Let's do a couple of quick examples.

Example 1 Compute the differentials for each of the following functions.

(a) $z = e^{x^2+y^2} \tan(2x)$

(b) $u = \frac{t^3 r^6}{s^2}$

Solution

(a) $z = e^{x^2+y^2} \tan(2x)$

There really isn't a whole lot to these outside of some quick differentiation. Here is the differential for the function.

$$dz = \left(2xe^{x^2+y^2} \tan(2x) + 2e^{x^2+y^2} \sec^2(2x) \right) dx + 2ye^{x^2+y^2} \tan(2x) dy$$

(b) $u = \frac{t^3 r^6}{s^2}$

Here is the differential for this function.

$$du = \frac{3t^2 r^6}{s^2} dt + \frac{6t^3 r^5}{s^2} dr - \frac{2t^3 r^6}{s^3} ds$$

Note that sometimes these differentials are called the **total differentials**.

Chain Rule

We've been using the standard chain rule for functions of one variable throughout the last couple of sections. It's now time to extend the chain rule out to more complicated situations. Before we actually do that let's first review the notation for the chain rule for functions of one variable.

The notation that's probably familiar to most people is the following.

$$F(x) = f(g(x)) \qquad F'(x) = f'(g(x))g'(x)$$

There is an alternate notation however that while probably not used much in Calculus I is more convenient at this point because it will match up with the notation that we are going to be using in this section. Here it is.

$$\text{If } y = f(x) \quad \text{and} \quad x = g(t) \quad \text{then} \quad \frac{dy}{dt} = \frac{dy}{dx} \frac{dx}{dt}$$

Notice that the derivative $\frac{dy}{dt}$ really does make sense here since if we were to plug in for x then y really would be a function of t . One way to remember this form of the chain rule is to note that if we think of the two derivatives on the right side as fractions the dx 's will cancel to get the same derivative on both sides.

Okay, now that we've got that out of the way let's move into the more complicated chain rules that we are liable to run across in this course.

As with many topics in multivariable calculus, there are in fact many different formulas depending upon the number of variables that we're dealing with. So, let's start this discussion off with a function of two variables, $z = f(x, y)$. From this point there are still many different possibilities that we can look at. We will be looking at two distinct cases prior to generalizing the whole idea out.

Case 1: $z = f(x, y)$, $x = g(t)$, $y = h(t)$ and compute $\frac{dz}{dt}$.

This case is analogous to the standard chain rule from Calculus I that we looked at above. In this case we are going to compute an ordinary derivative since z really would be a function of t only if we were to substitute in for x and y .

The chain rule for this case is,

$$\frac{dz}{dt} = \frac{\partial f}{\partial x} \frac{dx}{dt} + \frac{\partial f}{\partial y} \frac{dy}{dt}$$

So, basically what we're doing here is differentiating f with respect to each variable in it and then multiplying each of these by the derivative of that variable with respect to t . The final step is to then add all this up.

Let's take a look at a couple of examples.

Example 1 Compute $\frac{dz}{dt}$ for each of the following.

(a) $z = xe^{xy}$, $x = t^2$, $y = t^{-1}$ [[Solution](#)]

(b) $z = x^2y^3 + y \cos x$, $x = \ln(t^2)$, $y = \sin(4t)$ [[Solution](#)]

Solution

(a) $z = xe^{xy}$, $x = t^2$, $y = t^{-1}$

There really isn't all that much to do here other than using the formula.

$$\begin{aligned}\frac{dz}{dt} &= \frac{\partial f}{\partial x} \frac{dx}{dt} + \frac{\partial f}{\partial y} \frac{dy}{dt} \\ &= (\mathbf{e^{xy} + yxe^{xy}})(2t) + x^2\mathbf{e^{xy}}(-t^{-2}) \\ &= 2t(\mathbf{e^{xy} + yxe^{xy}}) - t^{-2}x^2\mathbf{e^{xy}}\end{aligned}$$

So, technically we've computed the derivative. However, we should probably go ahead and substitute in for x and y as well at this point since we've already got t 's in the derivative. Doing this gives,

$$\frac{dz}{dt} = 2t(\mathbf{e^t + te^t}) - t^{-2}t^4\mathbf{e^t} = 2te^t + t^2\mathbf{e^t}$$

Note that in this case it might actually have been easier to just substitute in for x and y in the original function and just compute the derivative as we normally would. For comparison's sake let's do that.

$$z = t^2\mathbf{e^t} \quad \Rightarrow \quad \frac{dz}{dt} = 2te^t + t^2\mathbf{e^t}$$

The same result for less work. Note however, that often it will actually be more work to do the substitution first.

[[Return to Problems](#)]

(b) $z = x^2y^3 + y \cos x$, $x = \ln(t^2)$, $y = \sin(4t)$

Okay, in this case it would almost definitely be more work to do the substitution first so we'll use the chain rule first and then substitute.

$$\begin{aligned}\frac{dz}{dt} &= (2xy^3 - y \sin x) \left(\frac{2}{t} \right) + (3x^2y^2 + \cos x)(4 \cos(4t)) \\ &= \frac{4 \sin^3(4t) \ln t^2 - 2 \sin(4t) \sin(\ln t^2)}{t} + 4 \cos(4t) \left(3 \sin^2(4t) [\ln t^2]^2 + \cos(\ln t^2) \right)\end{aligned}$$

Note that sometimes, because of the significant mess of the final answer, we will only simplify the first step a little and leave the answer in terms of x , y , and t . This is dependent upon the situation, class and instructor however and for this class we will pretty much always be substituting in for x and y .

[[Return to Problems](#)]

Now, there is a special case that we should take a quick look at before moving on to the next case. Let's suppose that we have the following situation,

$$z = f(x, y) \quad y = g(x)$$

In this case the chain rule for $\frac{dz}{dx}$ becomes,

$$\frac{dz}{dx} = \frac{\partial f}{\partial x} \frac{dx}{dx} + \frac{\partial f}{\partial y} \frac{dy}{dx} = \frac{\partial f}{\partial x} + \frac{\partial f}{\partial y} \frac{dy}{dx}$$

In the first term we are using the fact that,

$$\frac{dx}{dx} = \frac{d}{dx}(x) = 1$$

Let's take a quick look at an example.

Example 2 Compute $\frac{dz}{dx}$ for $z = x \ln(xy) + y^3$, $y = \cos(x^2 + 1)$

Solution

We'll just plug into the formula.

$$\begin{aligned} \frac{dz}{dx} &= \left(\ln(xy) + x \frac{y}{xy} \right) + \left(x \frac{x}{xy} + 3y^2 \right) (-2x \sin(x^2 + 1)) \\ &= \ln(x \cos(x^2 + 1)) + 1 - 2x \sin(x^2 + 1) \left(\frac{x}{\cos(x^2 + 1)} + 3 \cos^2(x^2 + 1) \right) \\ &= \ln(x \cos(x^2 + 1)) + 1 - 2x^2 \tan(x^2 + 1) - 6x \sin(x^2 + 1) \cos^2(x^2 + 1) \end{aligned}$$

Now let's take a look at the second case.

Case 2 : $z = f(x, y)$, $x = g(s, t)$, $y = h(s, t)$ and compute $\frac{\partial z}{\partial s}$ and $\frac{\partial z}{\partial t}$.

In this case if we were to substitute in for x and y we would get that z is a function of s and t and so it makes sense that we would be computing partial derivatives here and that there would be two of them.

Here is the chain rule for both of these cases.

$$\frac{\partial z}{\partial s} = \frac{\partial f}{\partial x} \frac{\partial x}{\partial s} + \frac{\partial f}{\partial y} \frac{\partial y}{\partial s} \quad \frac{\partial z}{\partial t} = \frac{\partial f}{\partial x} \frac{\partial x}{\partial t} + \frac{\partial f}{\partial y} \frac{\partial y}{\partial t}$$

So, not surprisingly, these are very similar to the first case that we looked at. Here is a quick example of this kind of chain rule.

Example 3 Find $\frac{\partial z}{\partial s}$ and $\frac{\partial z}{\partial t}$ for $z = e^{2r} \sin(3\theta)$, $r = st - t^2$, $\theta = \sqrt{s^2 + t^2}$.

Solution

Here is the chain rule for $\frac{\partial z}{\partial s}$.

$$\begin{aligned}\frac{\partial z}{\partial s} &= (2e^{2r} \sin(3\theta))(t) + (3e^{2r} \cos(3\theta)) \frac{s}{\sqrt{s^2 + t^2}} \\ &= t \left(2e^{2(st-t^2)} \sin(3\sqrt{s^2 + t^2}) \right) + \frac{3se^{2(st-t^2)} \cos(3\sqrt{s^2 + t^2})}{\sqrt{s^2 + t^2}}\end{aligned}$$

Now the chain rule for $\frac{\partial z}{\partial t}$.

$$\begin{aligned}\frac{\partial z}{\partial t} &= (2e^{2r} \sin(3\theta))(s - 2t) + (3e^{2r} \cos(3\theta)) \frac{t}{\sqrt{s^2 + t^2}} \\ &= (s - 2t) \left(2e^{2(st-t^2)} \sin(3\sqrt{s^2 + t^2}) \right) + \frac{3te^{2(st-t^2)} \cos(3\sqrt{s^2 + t^2})}{\sqrt{s^2 + t^2}}\end{aligned}$$

Okay, now that we've seen a couple of cases for the chain rule let's see the general version of the chain rule.

Chain Rule

Suppose that z is a function of n variables, x_1, x_2, \dots, x_n , and that each of these variables are in turn functions of m variables, t_1, t_2, \dots, t_m . Then for any variable t_i , $i = 1, 2, \dots, m$ we have the following,

$$\frac{\partial z}{\partial t_i} = \frac{\partial z}{\partial x_1} \frac{\partial x_1}{\partial t_i} + \frac{\partial z}{\partial x_2} \frac{\partial x_2}{\partial t_i} + \dots + \frac{\partial z}{\partial x_n} \frac{\partial x_n}{\partial t_i}$$

Wow. That's a lot to remember. There is actually an easier way to construct all the chain rules that we've discussed in the section or will look at in later examples. We can build up a **tree diagram** that will give us the chain rule for any situation. To see how these work let's go back and take a look at the chain rule for $\frac{\partial z}{\partial s}$ given that $z = f(x, y)$, $x = g(s, t)$, $y = h(s, t)$. We

already know what this is, but it may help to illustrate the tree diagram if we already know the answer. For reference here is the chain rule for this case,

$$\frac{\partial z}{\partial s} = \frac{\partial f}{\partial x} \frac{\partial x}{\partial s} + \frac{\partial f}{\partial y} \frac{\partial y}{\partial s}$$

Here is the tree diagram for this case.

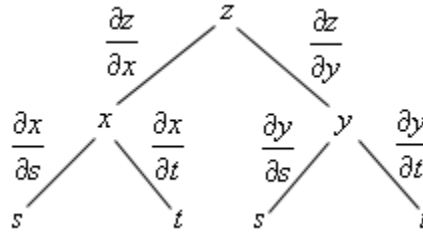

We start at the top with the function itself and the branch out from that point. The first set of branches is for the variables in the function. From each of these endpoints we put down a further set of branches that gives the variables that both x and y are a function of. We connect each letter with a line and each line represents a partial derivative as shown. Note that the letter in the numerator of the partial derivative is the upper “node” of the tree and the letter in the denominator of the partial derivative is the lower “node” of the tree.

To use this to get the chain rule we start at the bottom and for each branch that ends with the variable we want to take the derivative with respect to (s in this case) we move up the tree until we hit the top multiplying the derivatives that we see along that set of branches. Once we’ve done this for each branch that ends at s , we then add the results up to get the chain rule for that given situation.

Note that we don’t usually put the derivatives in the tree. They are always an assumed part of the tree.

Let’s write down some chain rules.

Example 4 Use a tree diagram to write down the chain rule for the given derivatives.

(a) $\frac{dw}{dt}$ for $w = f(x, y, z)$, $x = g_1(t)$, $y = g_2(t)$, and $z = g_3(t)$ [Solution]

(b) $\frac{\partial w}{\partial r}$ for $w = f(x, y, z)$, $x = g_1(s, t, r)$, $y = g_2(s, t, r)$, and $z = g_3(s, t, r)$
[Solution]

Solution

(a) $\frac{dw}{dt}$ for $w = f(x, y, z)$, $x = g_1(t)$, $y = g_2(t)$, and $z = g_3(t)$

So, we’ll first need the tree diagram so let’s get that.

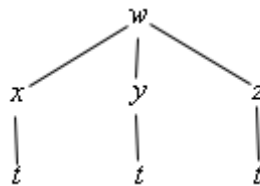

From this it looks like the chain rule for this case should be,

$$\frac{dw}{dt} = \frac{\partial f}{\partial x} \frac{dx}{dt} + \frac{\partial f}{\partial y} \frac{dy}{dt} + \frac{\partial f}{\partial z} \frac{dz}{dt}$$

which is really just a natural extension to the two variable case that we saw above.

[\[Return to Problems\]](#)

(b) $\frac{\partial w}{\partial r}$ for $w = f(x, y, z)$, $x = g_1(s, t, r)$, $y = g_2(s, t, r)$, and $z = g_3(s, t, r)$

Here is the tree diagram for this situation.

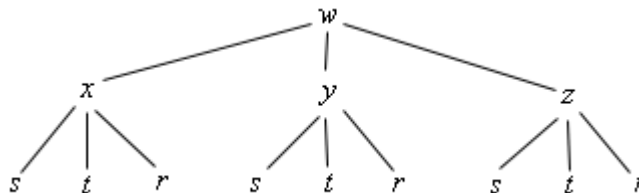

From this it looks like the derivative will be,

$$\frac{\partial w}{\partial r} = \frac{\partial f}{\partial x} \frac{\partial x}{\partial r} + \frac{\partial f}{\partial y} \frac{\partial y}{\partial r} + \frac{\partial f}{\partial z} \frac{\partial z}{\partial r}$$

[\[Return to Problems\]](#)

So, provided we can write down the tree diagram, and these aren't usually too bad to write down, we can do the chain rule for any set up that we might run across.

We've now seen how to take first derivatives of these more complicated situations, but what about higher order derivatives? How do we do those? It's probably easiest to see how to deal with these with an example.

Example 5 Compute $\frac{\partial^2 f}{\partial \theta^2}$ for $f(x, y)$ if $x = r \cos \theta$ and $y = r \sin \theta$.

Solution

We will need the first derivative before we can even think about finding the second derivative so let's get that. This situation falls into the second case that we looked at above so we don't need a new tree diagram. Here is the first derivative.

$$\begin{aligned} \frac{\partial f}{\partial \theta} &= \frac{\partial f}{\partial x} \frac{\partial x}{\partial \theta} + \frac{\partial f}{\partial y} \frac{\partial y}{\partial \theta} \\ &= -r \sin(\theta) \frac{\partial f}{\partial x} + r \cos(\theta) \frac{\partial f}{\partial y} \end{aligned}$$

Okay, now we know that the second derivative is,

$$\frac{\partial^2 f}{\partial \theta^2} = \frac{\partial}{\partial \theta} \left(\frac{\partial f}{\partial \theta} \right) = \frac{\partial}{\partial \theta} \left(-r \sin(\theta) \frac{\partial f}{\partial x} + r \cos(\theta) \frac{\partial f}{\partial y} \right)$$

The issue here is to correctly deal with this derivative. Since the two first order derivatives, $\frac{\partial f}{\partial x}$

and $\frac{\partial f}{\partial y}$, are both functions of x and y which are in turn functions of r and θ both of these terms are products. So, the using the product rule gives the following,

$$\frac{\partial^2 f}{\partial \theta^2} = -r \cos(\theta) \frac{\partial f}{\partial x} - r \sin(\theta) \frac{\partial}{\partial \theta} \left(\frac{\partial f}{\partial x} \right) - r \sin(\theta) \frac{\partial f}{\partial y} + r \cos(\theta) \frac{\partial}{\partial \theta} \left(\frac{\partial f}{\partial y} \right)$$

We now need to determine what $\frac{\partial}{\partial \theta} \left(\frac{\partial f}{\partial x} \right)$ and $\frac{\partial}{\partial \theta} \left(\frac{\partial f}{\partial y} \right)$ will be. These are both chain rule problems again since both of the derivatives are functions of x and y and we want to take the derivative with respect to θ .

Before we do these let's rewrite the first chain rule that we did above a little.

$$\frac{\partial}{\partial \theta} (f) = -r \sin(\theta) \frac{\partial}{\partial x} (f) + r \cos(\theta) \frac{\partial}{\partial y} (f) \quad (1)$$

Note that all we've done is change the notation for the derivative a little. With the first chain rule written in this way we can think of (1) as a formula for differentiating any function of x and y with respect to θ provided we have $x = r \cos \theta$ and $y = r \sin \theta$.

This however is exactly what we need to do the two new derivatives we need above. Both of the first order partial derivatives, $\frac{\partial f}{\partial x}$ and $\frac{\partial f}{\partial y}$, are functions of x and y and $x = r \cos \theta$ and $y = r \sin \theta$ so we can use (1) to compute these derivatives.

To do this we'll simply replace all the f 's in (1) with the first order partial derivative that we want to differentiate. At that point all we need to do is a little notational work and we'll get the formula that we're after.

Here is the use of (1) to compute $\frac{\partial}{\partial \theta} \left(\frac{\partial f}{\partial x} \right)$.

$$\begin{aligned} \frac{\partial}{\partial \theta} \left(\frac{\partial f}{\partial x} \right) &= -r \sin(\theta) \frac{\partial}{\partial x} \left(\frac{\partial f}{\partial x} \right) + r \cos(\theta) \frac{\partial}{\partial y} \left(\frac{\partial f}{\partial x} \right) \\ &= -r \sin(\theta) \frac{\partial^2 f}{\partial x^2} + r \cos(\theta) \frac{\partial^2 f}{\partial y \partial x} \end{aligned}$$

Here is the computation for $\frac{\partial}{\partial \theta} \left(\frac{\partial f}{\partial y} \right)$.

$$\begin{aligned}\frac{\partial}{\partial \theta} \left(\frac{\partial f}{\partial y} \right) &= -r \sin(\theta) \frac{\partial}{\partial x} \left(\frac{\partial f}{\partial y} \right) + r \cos(\theta) \frac{\partial}{\partial y} \left(\frac{\partial f}{\partial y} \right) \\ &= -r \sin(\theta) \frac{\partial^2 f}{\partial x \partial y} + r \cos(\theta) \frac{\partial^2 f}{\partial y^2}\end{aligned}$$

The final step is to plug these back into the second derivative and do some simplifying.

$$\begin{aligned}\frac{\partial^2 f}{\partial \theta^2} &= -r \cos(\theta) \frac{\partial f}{\partial x} - r \sin(\theta) \left(-r \sin(\theta) \frac{\partial^2 f}{\partial x^2} + r \cos(\theta) \frac{\partial^2 f}{\partial y \partial x} \right) - \\ &\quad r \sin(\theta) \frac{\partial f}{\partial y} + r \cos(\theta) \left(-r \sin(\theta) \frac{\partial^2 f}{\partial x \partial y} + r \cos(\theta) \frac{\partial^2 f}{\partial y^2} \right) \\ &= -r \cos(\theta) \frac{\partial f}{\partial x} + r^2 \sin^2(\theta) \frac{\partial^2 f}{\partial x^2} - r^2 \sin(\theta) \cos(\theta) \frac{\partial^2 f}{\partial y \partial x} - \\ &\quad r \sin(\theta) \frac{\partial f}{\partial y} - r^2 \sin(\theta) \cos(\theta) \frac{\partial^2 f}{\partial x \partial y} + r^2 \cos^2(\theta) \frac{\partial^2 f}{\partial y^2} \\ &= -r \cos(\theta) \frac{\partial f}{\partial x} - r \sin(\theta) \frac{\partial f}{\partial y} + r^2 \sin^2(\theta) \frac{\partial^2 f}{\partial x^2} - \\ &\quad 2r^2 \sin(\theta) \cos(\theta) \frac{\partial^2 f}{\partial y \partial x} + r^2 \cos^2(\theta) \frac{\partial^2 f}{\partial y^2}\end{aligned}$$

It's long and fairly messy but there it is.

The final topic in this section is a revisiting of implicit differentiation. With these forms of the chain rule implicit differentiation actually becomes a fairly simple process. Let's start out with the [implicit differentiation](#) that we saw in a Calculus I course.

We will start with a function in the form $F(x, y) = 0$ (if it's not in this form simply move everything to one side of the equal sign to get it into this form) where $y = y(x)$. In a Calculus I course we were then asked to compute $\frac{dy}{dx}$ and this was often a fairly messy process. Using the chain rule from this section however we can get a nice simple formula for doing this. We'll start by differentiating both sides with respect to x . This will mean using the chain rule on the left side and the right side will, of course, differentiate to zero. Here are the results of that.

$$F_x + F_y \frac{dy}{dx} = 0 \quad \Rightarrow \quad \frac{dy}{dx} = -\frac{F_x}{F_y}$$

As shown, all we need to do next is solve for $\frac{dy}{dx}$ and we've now got a very nice formula to use for implicit differentiation. Note as well that in order to simplify the formula we switched back to using the subscript notation for the derivatives.

Let's check out a quick example.

Example 6 Find $\frac{dy}{dx}$ for $x \cos(3y) + x^3 y^5 = 3x - e^{xy}$.

Solution

The first step is to get a zero on one side of the equal sign and that's easy enough to do.

$$x \cos(3y) + x^3 y^5 - 3x + e^{xy} = 0$$

Now, the function on the left is $F(x, y)$ in our formula so all we need to do is use the formula to find the derivative.

$$\frac{dy}{dx} = -\frac{\cos(3y) + 3x^2 y^5 - 3 + ye^{xy}}{-3x \sin(3y) + 5x^3 y^4 + xe^{xy}}$$

There we go. It would have taken much longer to do this using the old Calculus I way of doing this.

We can also do something similar to handle the types of implicit differentiation problems involving partial derivatives like those we saw when we first introduced partial derivatives. In these cases we will start off with a function in the form $F(x, y, z) = 0$ and assume that

$z = f(x, y)$ and we want to find $\frac{\partial z}{\partial x}$ and/or $\frac{\partial z}{\partial y}$.

Let's start by trying to find $\frac{\partial z}{\partial x}$. We will differentiate both sides with respect to x and we'll need to remember that we're going to be treating y as a constant. Also, the left side will require the chain rule. Here is this derivative.

$$\frac{\partial F}{\partial x} \frac{\partial x}{\partial x} + \frac{\partial F}{\partial y} \frac{\partial y}{\partial x} + \frac{\partial F}{\partial z} \frac{\partial z}{\partial x} = 0$$

Now, we have the following,

$$\frac{\partial x}{\partial x} = 1 \quad \text{and} \quad \frac{\partial y}{\partial x} = 0$$

The first is because we are just differentiating x with respect to x and we know that is 1. The second is because we are treating the y as a constant and so it will differentiate to zero.

Plugging these in and solving for $\frac{\partial z}{\partial x}$ gives,

$$\frac{\partial z}{\partial x} = -\frac{F_x}{F_z}$$

A similar argument can be used to show that,

$$\frac{\partial z}{\partial y} = -\frac{F_y}{F_z}$$

As with the one variable case we switched to the subscripting notation for derivatives to simplify the formulas. Let's take a quick look at an example of this.

Example 7 Find $\frac{\partial z}{\partial x}$ and $\frac{\partial z}{\partial y}$ for $x^2 \sin(2y - 5z) = 1 + y \cos(6zx)$.

Solution

This was one of the functions that we used the old implicit differentiation on back in the [Partial Derivatives](#) section. You might want to go back and see the difference between the two.

First let's get everything on one side.

$$x^2 \sin(2y - 5z) - 1 - y \cos(6zx) = 0$$

Now, the function on the left is $F(x, y, z)$ and so all that we need to do is use the formulas developed above to find the derivatives.

$$\frac{\partial z}{\partial x} = -\frac{2x \sin(2y - 5z) + 6yz \sin(6zx)}{-5x^2 \cos(2y - 5z) + 6yx \sin(6zx)}$$

$$\frac{\partial z}{\partial y} = -\frac{2x^2 \cos(2y - 5z) - \cos(6zx)}{-5x^2 \cos(2y - 5z) + 6yx \sin(6zx)}$$

If you go back and compare these answers to those that we found the first time around you will notice that they might appear to be different. However, if you take into account the minus sign that sits in the front of our answers here you will see that they are in fact the same.

Directional Derivatives

To this point we've only looked at the two partial derivatives $f_x(x, y)$ and $f_y(x, y)$. Recall that these derivatives represent the rate of change of f as we vary x (holding y fixed) and as we vary y (holding x fixed) respectively. We now need to discuss how to find the rate of change of f if we allow both x and y to change simultaneously. The problem here is that there are many ways to allow both x and y to change. For instance one could be changing faster than the other and then there is also the issue of whether or not each is increasing or decreasing. So, before we get into finding the rate of change we need to get a couple of preliminary ideas taken care of first. The main idea that we need to look at is just how are we going to define the changing of x and/or y .

Let's start off by supposing that we wanted the rate of change of f at a particular point, say (x_0, y_0) . Let's also suppose that both x and y are increasing and that, in this case, x is increasing twice as fast as y is increasing. So, as y increases one unit of measure x will increase two units of measure.

To help us see how we're going to define this change let's suppose that a particle is sitting at (x_0, y_0) and the particle will move in the direction given by the changing x and y . Therefore, the particle will move off in a direction of increasing x and y and the x coordinate of the point will increase twice as fast as the y coordinate. Now that we're thinking of this changing x and y as a direction of movement we can get a way of defining the change. We know from Calculus II that vectors can be used to define a direction and so the particle, at this point, can be said to be moving in the direction,

$$\vec{v} = \langle 2, 1 \rangle$$

Since this vector can be used to define how a particle at a point is changing we can also use it describe how x and/or y is changing at a point. For our example we will say that we want the rate of change of f in the direction of $\vec{v} = \langle 2, 1 \rangle$. In this way we will know that x is increasing twice as fast as y is. There is still a small problem with this however. There are many vectors that point in the same direction. For instance all of the following vectors point in the same direction as $\vec{v} = \langle 2, 1 \rangle$.

$$\vec{v} = \left\langle \frac{1}{5}, \frac{1}{10} \right\rangle \quad \vec{v} = \langle 6, 3 \rangle \quad \vec{v} = \left\langle \frac{2}{\sqrt{5}}, \frac{1}{\sqrt{5}} \right\rangle$$

We need a way to consistently find the rate of change of a function in a given direction. We will do this by insisting that the vector that defines the direction of change be a unit vector. Recall that a unit vector is a vector with length, or magnitude, of 1. This means that for the example that we started off thinking about we would want to use

$$\vec{v} = \left\langle \frac{2}{\sqrt{5}}, \frac{1}{\sqrt{5}} \right\rangle$$

since this is the unit vector that points in the direction of change.

For reference purposes recall that the magnitude or length of the vector $\vec{v} = \langle a, b, c \rangle$ is given by,

$$\|\vec{v}\| = \sqrt{a^2 + b^2 + c^2}$$

For two dimensional vectors we drop the c from the formula.

Sometimes we will give the direction of changing x and y as an angle. For instance, we may say that we want the rate of change of f in the direction of $\theta = \frac{\pi}{3}$. The unit vector that points in this direction is given by,

$$\vec{u} = \langle \cos \theta, \sin \theta \rangle$$

Okay, now that we know how to define the direction of changing x and y its time to start talking about finding the rate of change of f in this direction. Let's start off with the official definition.

Definition

The rate of change of $f(x, y)$ in the direction of the unit vector $\vec{u} = \langle a, b \rangle$ is called the **directional derivative** and is denoted by $D_{\vec{u}}f(x, y)$. The definition of the directional derivative is,

$$D_{\vec{u}}f(x, y) = \lim_{h \rightarrow 0} \frac{f(x + ah, y + bh) - f(x, y)}{h}$$

So, the definition of the directional derivative is very similar to the definition of partial derivatives. However, in practice this can be a very difficult limit to compute so we need an easier way of taking directional derivatives. It's actually fairly simple to derive an equivalent formula for taking directional derivatives.

To see how we can do this let's define a new function of a single variable,

$$g(z) = f(x_0 + az, y_0 + bz)$$

where x_0 , y_0 , a , and b are some fixed numbers. Note that this really is a function of a single variable now since z is the only letter that is not representing a fixed number.

Then by the definition of the derivative for functions of a single variable we have,

$$g'(z) = \lim_{h \rightarrow 0} \frac{g(z+h) - g(z)}{h}$$

and the derivative at $z = 0$ is given by,

$$g'(0) = \lim_{h \rightarrow 0} \frac{g(h) - g(0)}{h}$$

If we now substitute in for $g(z)$ we get,

$$g'(0) = \lim_{h \rightarrow 0} \frac{g(h) - g(0)}{h} = \lim_{h \rightarrow 0} \frac{f(x_0 + ah, y_0 + bh) - f(x_0, y_0)}{h} = D_{\vec{u}}f(x_0, y_0)$$

So, it looks like we have the following relationship.

$$g'(0) = D_{\vec{u}}f(x_0, y_0) \tag{1}$$

Now, let's look at this from another perspective. Let's rewrite $g(z)$ as follows,

$$g(z) = f(x, y) \text{ where } x = x_0 + az \text{ and } y = y_0 + bz$$

We can now use the chain rule from the previous section to compute,

$$g'(z) = \frac{dg}{dz} = \frac{\partial f}{\partial x} \frac{dx}{dz} + \frac{\partial f}{\partial y} \frac{dy}{dz} = f_x(x, y)a + f_y(x, y)b$$

So, from the chain rule we get the following relationship.

$$g'(z) = f_x(x, y)a + f_y(x, y)b \quad (2)$$

If we now take $z = 0$ we will get that $x = x_0$ and $y = y_0$ (from how we defined x and y above) and plug these into (2) we get,

$$g'(0) = f_x(x_0, y_0)a + f_y(x_0, y_0)b \quad (3)$$

Now, simply equate (1) and (3) to get that,

$$D_{\vec{u}}f(x_0, y_0) = g'(0) = f_x(x_0, y_0)a + f_y(x_0, y_0)b$$

If we now go back to allowing x and y to be any number we get the following formula for computing directional derivatives.

$$D_{\vec{u}}f(x, y) = f_x(x, y)a + f_y(x, y)b$$

This is much simpler than the limit definition. Also note that this definition assumed that we were working with functions of two variables. There are similar formulas that can be derived by the same type of argument for functions with more than two variables. For instance, the directional derivative of $f(x, y, z)$ in the direction of the unit vector $\vec{u} = \langle a, b, c \rangle$ is given by,

$$D_{\vec{u}}f(x, y, z) = f_x(x, y, z)a + f_y(x, y, z)b + f_z(x, y, z)c$$

Let's work a couple of examples.

Example 1 Find each of the directional derivatives.

(a) $D_{\vec{u}}f(2, 0)$ where $f(x, y) = xe^{xy} + y$ and \vec{u} is the unit vector in the direction

of $\theta = \frac{2\pi}{3}$. [\[Solution\]](#)

(b) $D_{\vec{u}}f(x, y, z)$ where $f(x, y, z) = x^2z + y^3z^2 - xyz$ in the direction of

$\vec{v} = \langle -1, 0, 3 \rangle$. [\[Solution\]](#)

Solution

(a) $D_{\vec{u}}f(2,0)$ where $f(x,y) = xe^{xy} + y$ and \vec{u} is the unit vector in the direction of $\theta = \frac{2\pi}{3}$.

We'll first find $D_{\vec{u}}f(x,y)$ and then use this a formula for finding $D_{\vec{u}}f(2,0)$. The unit vector giving the direction is,

$$\vec{u} = \left\langle \cos\left(\frac{2\pi}{3}\right), \sin\left(\frac{2\pi}{3}\right) \right\rangle = \left\langle -\frac{1}{2}, \frac{\sqrt{3}}{2} \right\rangle$$

So, the directional derivative is,

$$D_{\vec{u}}f(x,y) = \left(-\frac{1}{2}\right)(e^{xy} + xye^{xy}) + \left(\frac{\sqrt{3}}{2}\right)(x^2e^{xy} + 1)$$

Now, plugging in the point in question gives,

$$D_{\vec{u}}f(2,0) = \left(-\frac{1}{2}\right)(1) + \left(\frac{\sqrt{3}}{2}\right)(5) = \frac{5\sqrt{3}-1}{2}$$

[\[Return to Problems\]](#)

(b) $D_{\vec{u}}f(x,y,z)$ where $f(x,y,z) = x^2z + y^3z^2 - xyz$ in the direction of $\vec{v} = \langle -1, 0, 3 \rangle$.

In this case let's first check to see if the direction vector is a unit vector or not and if it isn't convert it into one. To do this all we need to do is compute its magnitude.

$$\|\vec{v}\| = \sqrt{1+0+9} = \sqrt{10} \neq 1$$

So, it's not a unit vector. Recall that we can convert any vector into a unit vector that points in the same direction by dividing the vector by its magnitude. So, the unit vector that we need is,

$$\vec{u} = \frac{1}{\sqrt{10}} \langle -1, 0, 3 \rangle = \left\langle -\frac{1}{\sqrt{10}}, 0, \frac{3}{\sqrt{10}} \right\rangle$$

The directional derivative is then,

$$\begin{aligned} D_{\vec{u}}f(x,y,z) &= \left(-\frac{1}{\sqrt{10}}\right)(2xz - yz) + (0)(3y^2z^2 - xz) + \left(\frac{3}{\sqrt{10}}\right)(x^2 + 2y^3z - xy) \\ &= \frac{1}{\sqrt{10}}(3x^2 + 6y^3z - 3xy - 2xz + yz) \end{aligned}$$

[\[Return to Problems\]](#)

There is another form of the formula that we used to get the directional derivative that is a little nicer and somewhat more compact. It is also a much more general formula that will encompass both of the formulas above.

Let's start with the second one and notice that we can write it as follows,

$$\begin{aligned} D_{\vec{u}}f(x, y, z) &= f_x(x, y, z)a + f_y(x, y, z)b + f_z(x, y, z)c \\ &= \langle f_x, f_y, f_z \rangle \cdot \langle a, b, c \rangle \end{aligned}$$

In other words we can write the directional derivative as a dot product and notice that the second vector is nothing more than the unit vector \vec{u} that gives the direction of change. Also, if we had used the version for functions of two variables the third component wouldn't be there, but other than that the formula would be the same.

Now let's give a name and notation to the first vector in the dot product since this vector will show up fairly regularly throughout this course (and in other courses). The **gradient of f** or **gradient vector of f** is defined to be,

$$\nabla f = \langle f_x, f_y, f_z \rangle \quad \text{or} \quad \nabla f = \langle f_x, f_y \rangle$$

Or, if we want to use the standard basis vectors the gradient is,

$$\nabla f = f_x \vec{i} + f_y \vec{j} + f_z \vec{k} \quad \text{or} \quad \nabla f = f_x \vec{i} + f_y \vec{j}$$

The definition is only shown for functions of two or three variables, however there is a natural extension to functions of any number of variables that we'd like.

With the definition of the gradient we can now say that the directional derivative is given by,

$$D_{\vec{u}}f = \nabla f \cdot \vec{u}$$

where we will no longer show the variable and use this formula for any number of variables. Note as well that we will sometimes use the following notation,

$$D_{\vec{u}}f(\vec{x}) = \nabla f \cdot \vec{u}$$

where $\vec{x} = \langle x, y, z \rangle$ or $\vec{x} = \langle x, y \rangle$ as needed. This notation will be used when we want to note the variables in some way, but don't really want to restrict ourselves to a particular number of variables. In other words, \vec{x} will be used to represent as many variables as we need in the formula and we will most often use this notation when we are already using vectors or vector notation in the problem/formula.

Let's work a couple of examples using this formula of the directional derivative.

Example 2 Find each of the directional derivative.

(a) $D_{\vec{u}}f(\vec{x})$ for $f(x, y) = x \cos(y)$ in the direction of $\vec{v} = \langle 2, 1 \rangle$. [\[Solution\]](#)

(b) $D_{\vec{u}}f(\vec{x})$ for $f(x, y, z) = \sin(yz) + \ln(x^2)$ at $(1, 1, \pi)$ in the direction of

$\vec{v} = \langle 1, 1, -1 \rangle$. [\[Solution\]](#)

Solution

(a) $D_{\vec{u}}f(\vec{x})$ for $f(x, y) = x \cos(y)$ in the direction of $\vec{v} = \langle 2, 1 \rangle$.

Let's first compute the gradient for this function.

$$\nabla f = \langle \cos(y), -x \sin(y) \rangle$$

Also, as we saw earlier in this section the unit vector for this direction is,

$$\vec{u} = \left\langle \frac{2}{\sqrt{5}}, \frac{1}{\sqrt{5}} \right\rangle$$

The directional derivative is then,

$$\begin{aligned} D_{\vec{u}}f(\vec{x}) &= \langle \cos(y), -x \sin(y) \rangle \cdot \left\langle \frac{2}{\sqrt{5}}, \frac{1}{\sqrt{5}} \right\rangle \\ &= \frac{1}{\sqrt{5}} (2 \cos(y) - x \sin(y)) \end{aligned}$$

[\[Return to Problems\]](#)

(b) $D_{\vec{u}}f(\vec{x})$ for $f(x, y, z) = \sin(yz) + \ln(x^2)$ at $(1, 1, \pi)$ in the direction of $\vec{v} = \langle 1, 1, -1 \rangle$.

In this case are asking for the directional derivative at a particular point. To do this we will first compute the gradient, evaluate it at the point in question and then do the dot product. So, let's get the gradient.

$$\begin{aligned} \nabla f(x, y, z) &= \left\langle \frac{2}{x}, z \cos(yz), y \cos(yz) \right\rangle \\ \nabla f(1, 1, \pi) &= \left\langle \frac{2}{1}, \pi \cos(\pi), \cos(\pi) \right\rangle = \langle 2, -\pi, -1 \rangle \end{aligned}$$

Next, we need the unit vector for the direction,

$$\|\vec{v}\| = \sqrt{3} \qquad \vec{u} = \left\langle \frac{1}{\sqrt{3}}, \frac{1}{\sqrt{3}}, -\frac{1}{\sqrt{3}} \right\rangle$$

Finally, the directional derivative at the point in question is,

$$\begin{aligned} D_{\vec{u}}f(1, 1, \pi) &= \langle 2, -\pi, -1 \rangle \cdot \left\langle \frac{1}{\sqrt{3}}, \frac{1}{\sqrt{3}}, -\frac{1}{\sqrt{3}} \right\rangle \\ &= \frac{1}{\sqrt{3}} (2 - \pi + 1) \\ &= \frac{3 - \pi}{\sqrt{3}} \end{aligned}$$

[\[Return to Problems\]](#)

Before proceeding let's note that the first order partial derivatives that we were looking at in the majority of the section can be thought of as special cases of the directional derivatives. For

instance, f_x can be thought of as the directional derivative of f in the direction of $\vec{u} = \langle 1, 0 \rangle$ or $\vec{u} = \langle 1, 0, 0 \rangle$, depending on the number of variables that we're working with. The same can be done for f_y and f_z .

We will close out this section with a couple of nice facts about the gradient vector. The first tells us how to determine the maximum rate of change of a function at a point and the direction that we need to move in order to achieve that maximum rate of change.

Theorem

The maximum value of $D_{\vec{u}}f(\vec{x})$ (and hence then the maximum rate of change of the function $f(\vec{x})$) is given by $\|\nabla f(\vec{x})\|$ and will occur in the direction given by $\nabla f(\vec{x})$.

Proof

This is a really simple proof. First, if we start with the dot product form $D_{\vec{u}}f(\vec{x})$ and use a nice [fact](#) about dot products as well as the fact that \vec{u} is a unit vector we get,

$$D_{\vec{u}}f = \nabla f \cdot \vec{u} = \|\nabla f\| \|\vec{u}\| \cos \theta = \|\nabla f\| \cos \theta$$

where θ is the angle between the gradient and \vec{u} .

Now the largest possible value of $\cos \theta$ is 1 which occurs at $\theta = 0$. Therefore the maximum value of $D_{\vec{u}}f(\vec{x})$ is $\|\nabla f(\vec{x})\|$. Also, the maximum value occurs when the angle between the gradient and \vec{u} is zero, or in other words when \vec{u} is pointing in the same direction as the gradient, $\nabla f(\vec{x})$.

■

Let's take a quick look at an example.

Example 3 Suppose that the height of a hill above sea level is given by $z = 1000 - 0.01x^2 - 0.02y^2$. If you are at the point $(60, 100)$ in what direction is the elevation changing fastest? What is the maximum rate of change of the elevation at this point?

Solution

First, you will hopefully recall from the [Quadric Surfaces](#) section that this is an elliptic paraboloid that opens downward. So even though most hills aren't this symmetrical it will at least be vaguely hill shaped and so the question makes at least a little sense.

Now on to the problem. There are a couple of questions to answer here, but using the theorem makes answering them very simple. We'll first need the gradient vector.

$$\nabla f(\vec{x}) = \langle -0.02x, -0.04y \rangle$$

The maximum rate of change of the elevation will then occur in the direction of

$$\nabla f(60, 100) = \langle -1.2, -4 \rangle$$

The maximum rate of change of the elevation at this point is,

$$\|\nabla f(60,100)\| = \sqrt{(-1.2)^2 + (4)^2} = \sqrt{17.44} = 4.176$$

Before leaving this example let's note that we're at the point $(60,100)$ and the direction of greatest rate of change of the elevation at this point is given by the vector $\langle -1.2, -4 \rangle$. Since both of the components are negative it looks like the direction of maximum rate of change points up the hill towards the center rather than away from the hill.

The second fact about the gradient vector that we need to give in this section will be very convenient in some later sections.

Fact

The gradient vector $\nabla f(x_0, y_0)$ is orthogonal (or perpendicular) to the [level curve](#) $f(x, y) = k$ at the point (x_0, y_0) . Likewise, the gradient vector $\nabla f(x_0, y_0, z_0)$ is orthogonal to the level surface $f(x, y, z) = k$ at the point (x_0, y_0, z_0) .

Proof

We're going to do the proof for the \mathbb{R}^3 case. The proof for the \mathbb{R}^2 case is identical. We'll also need some notation out of the way to make life easier for us let's let S be the level surface given by $f(x, y, z) = k$ and let $P = (x_0, y_0, z_0)$. Note as well that P will be on S .

Now, let C be any curve on S that contains P . Let $\vec{r}(t) = \langle x(t), y(t), z(t) \rangle$ be the vector equation for C and suppose that t_0 be the value of t such that $\vec{r}(t_0) = \langle x_0, y_0, z_0 \rangle$. In other words, t_0 be the value of t that gives P .

Because C lies on S we know that points on C must satisfy the equation for S . Or,

$$f(x(t), y(t), z(t)) = k$$

Next, let's use the Chain Rule on this to get,

$$\frac{\partial f}{\partial x} \frac{dx}{dt} + \frac{\partial f}{\partial y} \frac{dy}{dt} + \frac{\partial f}{\partial z} \frac{dz}{dt} = 0 \quad (4)$$

Notice that $\nabla f = \langle f_x, f_y, f_z \rangle$ and $\vec{r}'(t) = \langle x'(t), y'(t), z'(t) \rangle$ so (4) becomes,

$$\nabla f \cdot \vec{r}'(t) = 0$$

At, $t = t_0$ this is,

$$\nabla f(x_0, y_0, z_0) \cdot \vec{r}'(t_0) = 0$$

This then tells us that the gradient vector at P , $\nabla f(x_0, y_0, z_0)$, is orthogonal to the tangent

vector, $\vec{r}'(t_0)$, to any curve C that passes through P and on the surface S and so must also be orthogonal to the surface S .



As we will be seeing in later sections we are often going to be needing vectors that are orthogonal to a surface or curve and using this fact we will know that all we need to do is compute a gradient vector and we will get the orthogonal vector that we need. We will see the first application of this in the next chapter.

Applications of Partial Derivatives

Introduction

In this section we will take a look at a couple of applications of partial derivatives. Most of the applications will be extensions to applications to ordinary derivatives that we saw back in Calculus I. For instance, we will be looking at finding the absolute and relative extrema of a function and we will also be looking at optimization. Both (all three?) of these subjects were major applications back in Calculus I. They will, however, be a little more work here because we now have more than one variable.

Here is a list of the topics in this chapter.

[Tangent Planes and Linear Approximations](#) – We'll take a look at tangent planes to surfaces in this section as well as an application of tangent planes.

[Gradient Vector, Tangent Planes and Normal Lines](#) – In this section we'll see how the gradient vector can be used to find tangent planes and normal lines to a surface.

[Relative Minimums and Maximums](#) – Here we will see how to identify relative minimums and maximums.

[Absolute Minimums and Maximums](#) – We will find absolute minimums and maximums of a function over a given region.

[Lagrange Multipliers](#) – In this section we'll see how to use Lagrange Multipliers to find the absolute extrema for a function subject to a given constraint.

Tangent Planes and Linear Approximations

Earlier we [saw](#) how the two partial derivatives f_x and f_y can be thought of as the slopes of traces. We want to extend this idea out a little in this section. The graph of a function $z = f(x, y)$ is a surface in \mathbb{R}^3 (three dimensional space) and so we can now start thinking of the plane that is “tangent” to the surface as a point.

Let’s start out with a point (x_0, y_0) and let’s let C_1 represent the trace to $f(x, y)$ for the plane $y = y_0$ (*i.e.* allowing x to vary with y held fixed) and we’ll let C_2 represent the trace to $f(x, y)$ for the plane $x = x_0$ (*i.e.* allowing y to vary with x held fixed). Now, we know that $f_x(x_0, y_0)$ is the slope of the tangent line to the trace C_1 and $f_y(x_0, y_0)$ is the slope of the tangent line to the trace C_2 . So, let L_1 be the tangent line to the trace C_1 and let L_2 be the tangent line to the trace C_2 .

The tangent plane will then be the plane that contains the two lines L_1 and L_2 . Geometrically this plane will serve the same purpose that a tangent line did in Calculus I. A tangent line to a curve was a line that just touched the curve at that point and was “parallel” to the curve at the point in question. Well tangent planes to a surface are planes that just touch the surface at the point and are “parallel” to the surface at the point. Note that this gives us a point that is on the plane. Since the tangent plane and the surface touch at (x_0, y_0) the following point will be on both the surface and the plane.

$$(x_0, y_0, z_0) = (x_0, y_0, f(x_0, y_0))$$

What we need to do now is determine the equation of the tangent plane. We [know](#) that the general equation of a plane is given by,

$$a(x - x_0) + b(y - y_0) + c(z - z_0) = 0$$

where (x_0, y_0, z_0) is a point that is on the plane, which we know already. Let’s rewrite this a little. We’ll move the x terms and y terms to the other side and divide both sides by c . Doing this gives,

$$z - z_0 = -\frac{a}{c}(x - x_0) - \frac{b}{c}(y - y_0)$$

Now, let’s rename the constants to simplify up the notation a little. Let’s rename them as follows,

$$A = -\frac{a}{c} \quad B = -\frac{b}{c}$$

With this renaming the equation of the tangent plane becomes,

$$z - z_0 = A(x - x_0) + B(y - y_0)$$

and we need to determine values for A and B .

Let's first think about what happens if we hold y fixed, *i.e.* if we assume that $y = y_0$. In this case the equation of the tangent plane becomes,

$$z - z_0 = A(x - x_0)$$

This is the equation of a line and this line must be tangent to the surface at (x_0, y_0) (since it's part of the tangent plane). In addition, this line assumes that $y = y_0$ (*i.e.* fixed) and A is the slope of this line. But if we think about it this is exactly what the tangent to C_1 is, a line tangent to the surface at (x_0, y_0) assuming that $y = y_0$. In other words,

$$z - z_0 = A(x - x_0)$$

is the equation for L_1 and we know that the slope of L_1 is given by $f_x(x_0, y_0)$. Therefore we have the following,

$$A = f_x(x_0, y_0)$$

If we hold x fixed at $x = x_0$ the equation of the tangent plane becomes,

$$z - z_0 = B(y - y_0)$$

However, by a similar argument to the one above we can see that this is nothing more than the equation for L_2 and that it's slope is B or $f_y(x_0, y_0)$. So,

$$B = f_y(x_0, y_0)$$

The equation of the tangent plane to the surface given by $z = f(x, y)$ at (x_0, y_0) is then,

$$z - z_0 = f_x(x_0, y_0)(x - x_0) + f_y(x_0, y_0)(y - y_0)$$

Also, if we use the fact that $z_0 = f(x_0, y_0)$ we can rewrite the equation of the tangent plane as,

$$\begin{aligned} z - f(x_0, y_0) &= f_x(x_0, y_0)(x - x_0) + f_y(x_0, y_0)(y - y_0) \\ z &= f(x_0, y_0) + f_x(x_0, y_0)(x - x_0) + f_y(x_0, y_0)(y - y_0) \end{aligned}$$

We will see an easier derivation of this formula (actually a more general formula) in the next section so if you didn't quite follow this argument hold off until then to see a better derivation.

Example 1 Find the equation of the tangent plane to $z = \ln(2x + y)$ at $(-1, 3)$.

Solution

There really isn't too much to do here other than taking a couple of derivatives and doing some quick evaluations.

$$f(x, y) = \ln(2x + y) \qquad z_0 = f(-1, 3) = \ln(1) = 0$$

$$f_x(x, y) = \frac{2}{2x + y} \qquad f_x(-1, 3) = 2$$

$$f_y(x, y) = \frac{1}{2x + y} \qquad f_y(-1, 3) = 1$$

The equation of the plane is then,

$$z - 0 = 2(x + 1) + (1)(y - 3)$$

$$z = 2x + y - 1$$

One nice use of tangent planes is they give us a way to approximate a surface near a point. As long as we are near to the point (x_0, y_0) then the tangent plane should nearly approximate the function at that point. Because of this we define the **linear approximation** to be,

$$L(x, y) = f(x_0, y_0) + f_x(x_0, y_0)(x - x_0) + f_y(x_0, y_0)(y - y_0)$$

and as long as we are “near” (x_0, y_0) then we should have that,

$$f(x, y) \approx L(x, y) = f(x_0, y_0) + f_x(x_0, y_0)(x - x_0) + f_y(x_0, y_0)(y - y_0)$$

Example 2 Find the linear approximation to $z = 3 + \frac{x^2}{16} + \frac{y^2}{9}$ at $(-4, 3)$.

Solution

So, we’re really asking for the tangent plane so let’s find that.

$$f(x, y) = 3 + \frac{x^2}{16} + \frac{y^2}{9} \qquad f(-4, 3) = 3 + 1 + 1 = 5$$

$$f_x(x, y) = \frac{x}{8} \qquad f_x(-4, 3) = -\frac{1}{2}$$

$$f_y(x, y) = \frac{2y}{9} \qquad f_y(-4, 3) = \frac{2}{3}$$

The tangent plane, or linear approximation, is then,

$$L(x, y) = 5 - \frac{1}{2}(x + 4) + \frac{2}{3}(y - 3)$$

For reference purposes here is a sketch of the surface and the tangent plane/linear approximation.

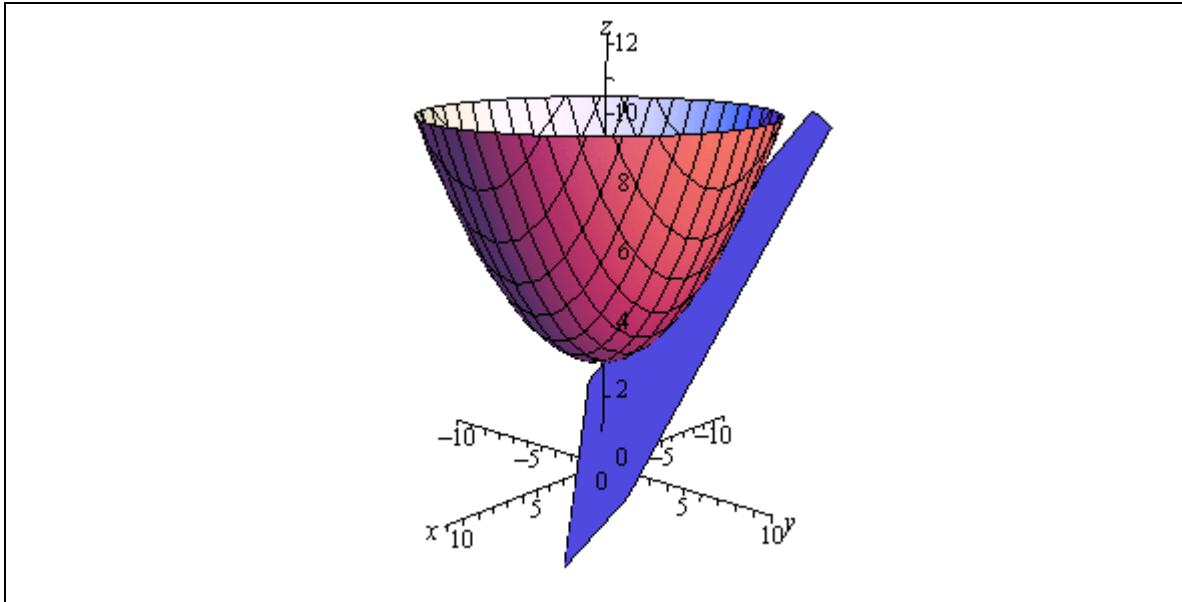

Gradient Vector, Tangent Planes and Normal Lines

In this section we want to revisit tangent planes only this time we'll look at them in light of the gradient vector. In the process we will also take a look at a normal line to a surface.

Let's first recall the equation of a plane that contains the point (x_0, y_0, z_0) with normal vector $\vec{n} = \langle a, b, c \rangle$ is given by,

$$a(x - x_0) + b(y - y_0) + c(z - z_0) = 0$$

When we introduced the gradient vector in the section on [directional derivatives](#) we gave the following fact.

Fact

The gradient vector $\nabla f(x_0, y_0)$ is orthogonal (or perpendicular) to the [level curve](#) $f(x, y) = k$ at the point (x_0, y_0) . Likewise, the gradient vector $\nabla f(x_0, y_0, z_0)$ is orthogonal to the level surface $f(x, y, z) = k$ at the point (x_0, y_0, z_0) .

Actually, all we need here is the last part of this fact. This says that the gradient vector is always orthogonal, or *normal*, to the surface at a point.

Also recall that the gradient vector is,

$$\nabla f = \langle f_x, f_y, f_z \rangle$$

So, the tangent plane to the surface given by $f(x, y, z) = k$ at (x_0, y_0, z_0) has the equation,

$$f_x(x_0, y_0, z_0)(x - x_0) + f_y(x_0, y_0, z_0)(y - y_0) + f_z(x_0, y_0, z_0)(z - z_0) = 0$$

This is a much more general form of the equation of a tangent plane than the one that we derived in the previous section.

Note however, that we can also get the equation from the previous section using this more general formula. To see this let's start with the equation $z = f(x, y)$ and we want to find the tangent plane to the surface given by $z = f(x, y)$ at the point (x_0, y_0, z_0) where $z_0 = f(x_0, y_0)$. In order to use the formula above we need to have all the variables on one side. This is easy enough to do. All we need to do is subtract a z from both sides to get,

$$f(x, y) - z = 0$$

Now, if we define a new function

$$F(x, y, z) = f(x, y) - z$$

we can see that the surface given by $z = f(x, y)$ is identical to the surface given by

$F(x, y, z) = 0$ and this new equivalent equation is in the correct form for the equation of the tangent plane that we derived in this section.

So, the first thing that we need to do is find the gradient vector for F .

$$\nabla F = \langle F_x, F_y, F_z \rangle = \langle f_x, f_y, -1 \rangle$$

Notice that

$$F_x = \frac{\partial}{\partial x}(f(x, y) - z) = f_x \qquad F_y = \frac{\partial}{\partial y}(f(x, y) - z) = f_y$$

$$F_z = \frac{\partial}{\partial z}(f(x, y) - z) = -1$$

The equation of the tangent plane is then,

$$f_x(x_0, y_0)(x - x_0) + f_y(x_0, y_0)(y - y_0) - (z - z_0) = 0$$

Or, upon solving for z , we get,

$$z = f(x_0, y_0) + f_x(x_0, y_0)(x - x_0) + f_y(x_0, y_0)(y - y_0)$$

which is identical to the equation that we derived in the previous section.

We can get another nice piece of information out of the gradient vector as well. We might on occasion want a line that is orthogonal to a surface at a point, sometimes called the **normal line**. This is easy enough to get if we recall that the [equation of a line](#) only requires that we have a point and a parallel vector. Since we want a line that is at the point (x_0, y_0, z_0) we know that this point must also be on the line and we know that $\nabla f(x_0, y_0, z_0)$ is a vector that is normal to the surface and hence will be parallel to the line. Therefore the equation of the normal line is,

$$\vec{r}(t) = \langle x_0, y_0, z_0 \rangle + t \nabla f(x_0, y_0, z_0)$$

Example 1 Find the tangent plane and normal line to $x^2 + y^2 + z^2 = 30$ at the point $(1, -2, 5)$.

Solution

For this case the function that we're going to be working with is,

$$F(x, y, z) = x^2 + y^2 + z^2$$

and note that we don't have to have a zero on one side of the equal sign. All that we need is a constant. To finish this problem out we simply need the gradient evaluated at the point.

$$\nabla F = \langle 2x, 2y, 2z \rangle$$

$$\nabla F(1, -2, 5) = \langle 2, -4, 10 \rangle$$

The tangent plane is then,

$$2(x - 1) - 4(y + 2) + 10(z - 5) = 0$$

The normal line is,

$$\vec{r}(t) = \langle 1, -2, 5 \rangle + t \langle 2, -4, 10 \rangle = \langle 1 + 2t, -2 - 4t, 5 + 10t \rangle$$

Relative Minimums and Maximums

In this section we are going to extend one of the more important ideas from Calculus I into functions of two variables. We are going to start looking at trying to find minimums and maximums of functions. This in fact will be the topic of the following two sections as well.

In this section we are going to be looking at identifying relative minimums and relative maximums. Recall as well that we will often use the word extrema to refer to both minimums and maximums.

The definition of relative extrema for functions of two variables is identical to that for functions of one variable we just need to remember now that we are working with functions of two variables. So, for the sake of completeness here is the definition of relative minimums and relative maximums for functions of two variables.

Definition

1. A function $f(x, y)$ has a **relative minimum** at the point (a, b) if $f(x, y) \geq f(a, b)$ for all points (x, y) in some region around (a, b) .
2. A function $f(x, y)$ has a **relative maximum** at the point (a, b) if $f(x, y) \leq f(a, b)$ for all points (x, y) in some region around (a, b) .

Note that this definition does not say that a relative minimum is the smallest value that the function will ever take. It only says that in some region around the point (a, b) the function will always be larger than $f(a, b)$. Outside of that region it is completely possible for the function to be smaller. Likewise, a relative maximum only says that around (a, b) the function will always be smaller than $f(a, b)$. Again, outside of the region it is completely possible that the function will be larger.

Next we need to extend the idea of **critical points** up to functions of two variables. Recall that a critical point of the function $f(x)$ was a number $x = c$ so that either $f'(c) = 0$ or $f'(c)$ doesn't exist. We have a similar definition for critical points of functions of two variables.

Definition

The point (a, b) is a **critical point** (or a **stationary point**) of $f(x, y)$ provided one of the following is true,

1. $\nabla f(a, b) = \vec{0}$ (this is equivalent to saying that $f_x(a, b) = 0$ and $f_y(a, b) = 0$),
2. $f_x(a, b)$ and/or $f_y(a, b)$ doesn't exist.

To see the equivalence in the first part let's start off with $\nabla f = \vec{0}$ and put in the definition of each part.

$$\nabla f(a, b) = \vec{0}$$

$$\langle f_x(a, b), f_y(a, b) \rangle = \langle 0, 0 \rangle$$

The only way that these two vectors can be equal is to have $f_x(a, b) = 0$ and $f_y(a, b) = 0$. In fact, we will use this definition of the critical point more than the gradient definition since it will be easier to find the critical points if we start with the partial derivative definition.

Note as well that BOTH of the first order partial derivatives must be zero at (a, b) . If only one of the first order partial derivatives are zero at the point then the point will NOT be a critical point.

We now have the following fact that, at least partially, relates critical points to relative extrema.

Fact

If the point (a, b) is a relative extrema of the function $f(x, y)$ then (a, b) is also a critical point of $f(x, y)$ and in fact we'll have $\nabla f(a, b) = \vec{0}$.

Proof

This is a really simple proof that relies on the single variable version that we [saw](#) in Calculus I version, often called Fermat's Theorem.

Let's start off by defining $g(x) = f(x, b)$ and suppose that $f(x, y)$ has a relative extrema at (a, b) . However, this also means that $g(x)$ also has a relative extrema (of the same kind as $f(x, y)$) at $x = a$. By Fermat's Theorem we then know that $g'(a) = 0$. But we also know that $g'(a) = f_x(a, b)$ and so we have that $f_x(a, b) = 0$.

If we now define $h(y) = f(a, y)$ and going through exactly the same process as above we will see that $f_y(a, b) = 0$.

So, putting all this together means that $\nabla f(a, b) = \vec{0}$ and so $f(x, y)$ has a critical point at (a, b) .



Note that this does NOT say that all critical points are relative extrema. It only says that relative extrema will be critical points of the function. To see this let's consider the function

$$f(x, y) = xy$$

The two first order partial derivatives are,

$$f_x(x, y) = y$$

$$f_y(x, y) = x$$

The only point that will make both of these derivatives zero at the same time is $(0, 0)$ and so $(0, 0)$ is a critical point for the function. Here is a graph of the function.

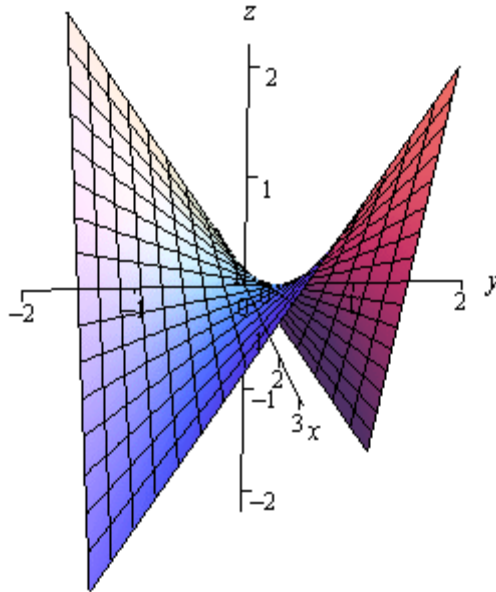

Note that the axes are not in the standard orientation here so that we can see more clearly what is happening at the origin, *i.e.* at $(0, 0)$. If we start at the origin and move into either of the quadrants where both x and y are the same sign the function increases. However, if we start at the origin and move into either of the quadrants where x and y have the opposite sign then the function decreases. In other words, no matter what region you take about the origin there will be points larger than $f(0, 0) = 0$ and points smaller than $f(0, 0) = 0$. Therefore, there is no way that $(0, 0)$ can be a relative extrema.

Critical points that exhibit this kind of behavior are called **saddle points**.

While we have to be careful to not misinterpret the results of this fact it is very useful in helping us to identify relative extrema. Because of this fact we know that if we have all the critical points of a function then we also have every possible relative extrema for the function. The fact tells us that all relative extrema must be critical points so we know that if the function does have relative extrema then they must be in the collection of all the critical points. Remember however, that it will be completely possible that at least one of the critical points won't be a relative extrema.

So, once we have all the critical points in hand all we will need to do is test these points to see if they are relative extrema or not. To determine if a critical point is a relative extrema (and in fact to determine if it is a minimum or a maximum) we can use the following fact.

Fact

Suppose that (a, b) is a critical point of $f(x, y)$ and that the second order partial derivatives are continuous in some region that contains (a, b) . Next define,

$$D = D(a, b) = f_{xx}(a, b)f_{yy}(a, b) - [f_{xy}(a, b)]^2$$

We then have the following classifications of the critical point.

1. If $D > 0$ and $f_{xx}(a, b) > 0$ then there is a relative minimum at (a, b) .
2. If $D > 0$ and $f_{xx}(a, b) < 0$ then there is a relative maximum at (a, b) .
3. If $D < 0$ then the point (a, b) is a saddle point.
4. If $D = 0$ then the point (a, b) may be a relative minimum, relative maximum or a saddle point. Other techniques would need to be used to classify the critical point.

Note that if $D > 0$ then both $f_{xx}(a, b)$ and $f_{yy}(a, b)$ will have the same sign and so in the first two cases above we could just as easily replace $f_{xx}(a, b)$ with $f_{yy}(a, b)$. Also note that we aren't going to be seeing any cases in this class where $D = 0$. We will be able to classify all the critical points that we find.

Let's see a couple of examples.

Example 1 Find and classify all the critical points of $f(x, y) = 4 + x^3 + y^3 - 3xy$.

Solution

We first need all the first order (to find the critical points) and second order (to classify the critical points) partial derivatives so let's get those.

$$\begin{aligned} f_x &= 3x^2 - 3y & f_y &= 3y^2 - 3x \\ f_{xx} &= 6x & f_{yy} &= 6y & f_{xy} &= -3 \end{aligned}$$

Let's first find the critical points. Critical points will be solutions to the system of equations,

$$\begin{aligned} f_x &= 3x^2 - 3y = 0 \\ f_y &= 3y^2 - 3x = 0 \end{aligned}$$

This is a non-linear system of equations and these can, on occasion, be difficult to solve. However, in this case it's not too bad. We can solve the first equation for y as follows,

$$3x^2 - 3y = 0 \quad \Rightarrow \quad y = x^2$$

Plugging this into the second equation gives,

$$3(x^2)^2 - 3x = 3x(x^3 - 1) = 0$$

From this we can see that we must have $x = 0$ or $x = 1$. Now use the fact that $y = x^2$ to get the

critical points.

$$x = 0: y = 0^2 = 0 \quad \Rightarrow \quad (0, 0)$$

$$x = 1: y = 1^2 = 1 \quad \Rightarrow \quad (1, 1)$$

So, we get two critical points. All we need to do now is classify them. To do this we will need D . Here is the general formula for D .

$$\begin{aligned} D(x, y) &= f_{xx}(x, y)f_{yy}(x, y) - [f_{xy}(x, y)]^2 \\ &= (6x)(6y) - (-3)^2 \\ &= 36xy - 9 \end{aligned}$$

To classify the critical points all that we need to do is plug in the critical points and use the fact above to classify them.

$(0, 0)$:

$$D = D(0, 0) = -9 < 0$$

So, for $(0, 0)$ D is negative and so this must be a saddle point.

$(1, 1)$:

$$D = D(1, 1) = 36 - 9 = 27 > 0 \quad f_{xx}(1, 1) = 6 > 0$$

For $(1, 1)$ D is positive and f_{xx} is positive and so we must have a relative minimum.

For the sake of completeness here is a graph of this function.

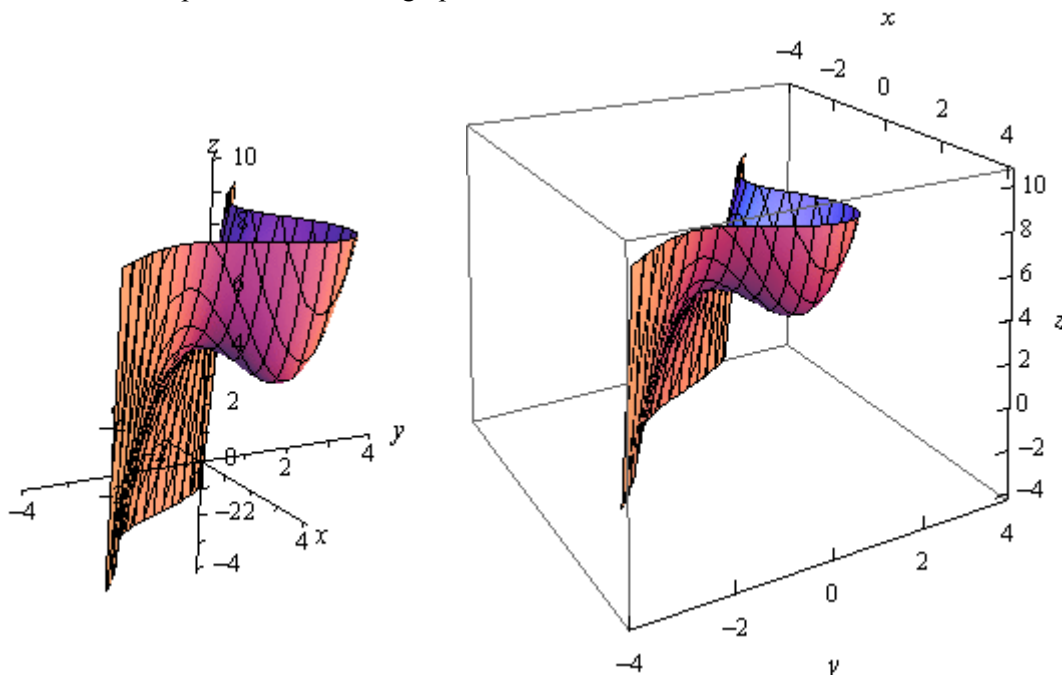

Notice that in order to get a better visual we used a somewhat nonstandard orientation. We can see that there is a relative minimum at $(1,1)$ and (hopefully) it's clear that at $(0,0)$ we do get a saddle point.

Example 2 Find and classify all the critical points for $f(x, y) = 3x^2y + y^3 - 3x^2 - 3y^2 + 2$

Solution

As with the first example we will first need to get all the first and second order derivatives.

$$\begin{aligned} f_x &= 6xy - 6x & f_y &= 3x^2 + 3y^2 - 6y \\ f_{xx} &= 6y - 6 & f_{yy} &= 6y - 6 & f_{xy} &= 6x \end{aligned}$$

We'll first need the critical points. The equations that we'll need to solve this time are,

$$\begin{aligned} 6xy - 6x &= 0 \\ 3x^2 + 3y^2 - 6y &= 0 \end{aligned}$$

These equations are a little trickier to solve than the first set, but once you see what to do they really aren't terribly bad.

First, let's notice that we can factor out a $6x$ from the first equation to get,

$$6x(y-1) = 0$$

So, we can see that the first equation will be zero if $x = 0$ or $y = 1$. Be careful to not just cancel the x from both sides. If we had done that we would have missed $x = 0$.

To find the critical points we can plug these (individually) into the second equation and solve for the remaining variable.

$x = 0$:

$$3y^2 - 6y = 3y(y-2) = 0 \quad \Rightarrow \quad y = 0, y = 2$$

$y = 1$:

$$3x^2 - 3 = 3(x^2 - 1) = 0 \quad \Rightarrow \quad x = -1, x = 1$$

So, if $x = 0$ we have the following critical points,

$$(0,0) \quad (0,2)$$

and if $y = 1$ the critical points are,

$$(1,1) \quad (-1,1)$$

Now all we need to do is classify the critical points. To do this we'll need the general formula for D .

$$D(x, y) = (6y - 6)(6y - 6) - (6x)^2 = (6y - 6)^2 - 36x^2$$

$(0,0)$:

$$D = D(0,0) = 36 > 0 \quad f_{xx}(0,0) = -6 < 0$$

$(0,2)$:

$$D = D(0,2) = 36 > 0 \quad f_{xx}(0,2) = 6 > 0$$

$(1,1)$:

$$D = D(1,1) = -36 < 0$$

$(-1,1)$:

$$D = D(-1,1) = -36 < 0$$

So, it looks like we have the following classification of each of these critical points.

$(0,0)$: Relative Maximum

$(0,2)$: Relative Minimum

$(1,1)$: Saddle Point

$(-1,1)$: Saddle Point

Here is a graph of the surface for the sake of completeness.

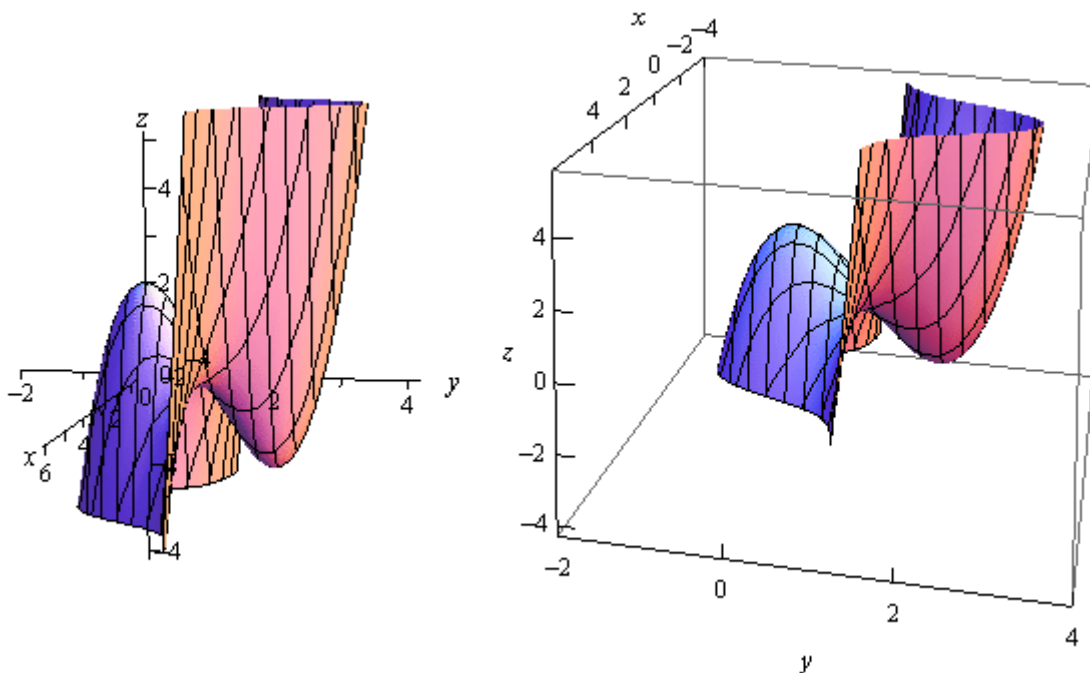

Let's do one more example that is a little different from the first two.

Example 3 Determine the point on the plane $4x - 2y + z = 1$ that is closest to the point $(-2, -1, 5)$.

Solution

Note that we are NOT asking for the critical points of the plane. In order to do this example we are going to need to first come up with the equation that we are going to have to work with.

First, let's suppose that (x, y, z) is any point on the plane. The distance between this point and the point in question, $(-2, -1, 5)$, is given by the formula,

$$d = \sqrt{(x+2)^2 + (y+1)^2 + (z-5)^2}$$

What we are then asked to find is the minimum value of this equation. The point (x, y, z) that gives the minimum value of this equation will be the point on the plane that is closest to $(-2, -1, 5)$.

There are a couple of issues with this equation. First, it is a function of x, y and z and we can only deal with functions of x and y at this point. However, this is easy to fix. We can solve the equation of the plane to see that,

$$z = 1 - 4x + 2y$$

Plugging this into the distance formula gives,

$$\begin{aligned} d &= \sqrt{(x+2)^2 + (y+1)^2 + (1-4x+2y-5)^2} \\ &= \sqrt{(x+2)^2 + (y+1)^2 + (-4-4x+2y)^2} \end{aligned}$$

Now, the next issue is that there is a square root in this formula and we know that we're going to be differentiating this eventually. So, in order to make our life a little easier let's notice that finding the minimum value of d will be equivalent to finding the minimum value of d^2 .

So, let's instead find the minimum value of

$$f(x, y) = d^2 = (x+2)^2 + (y+1)^2 + (-4-4x+2y)^2$$

Now, we need to be a little careful here. We are being asked to find the closest point on the plane to $(-2, -1, 5)$ and that is not really the same thing as what we've been doing in this section. In this section we've been finding and classifying critical points as relative minimums or maximums and what we are really asking is to find the smallest value the function will take, or the absolute minimum. Hopefully, it does make sense from a physical standpoint that there will be a closest point on the plane to $(-2, -1, 5)$. Also, this point should be a relative minimum.

So, let's go through the process from the first and second example and see what we get as far as relative minimums go. If we only get a single relative minimum then we will be done since that point will also need to be the absolute minimum of the function and hence the point on the plane

that is closest to $(-2, -1, 5)$.

We'll need the derivatives first.

$$f_x = 2(x+2) + 2(-4)(-4-4x+2y) = 36 + 34x - 16y$$

$$f_y = 2(y+1) + 2(2)(-4-4x+2y) = -14 - 16x + 10y$$

$$f_{xx} = 34$$

$$f_{yy} = 10$$

$$f_{xy} = -16$$

Now, before we get into finding the critical point let's compute D quickly.

$$D = 34(10) - (-16)^2 = 84 > 0$$

So, in this case D will always be positive and also notice that $f_{xx} = 34 > 0$ is always positive and so any critical points that we get will be guaranteed to be relative minimums.

Now let's find the critical point(s). This will mean solving the system.

$$36 + 34x - 16y = 0$$

$$-14 - 16x + 10y = 0$$

To do this we can solve the first equation for x .

$$x = \frac{1}{34}(16y - 36) = \frac{1}{17}(8y - 18)$$

Now, plug this into the second equation and solve for y .

$$-14 - \frac{16}{17}(8y - 18) + 10y = 0 \quad \Rightarrow \quad y = -\frac{25}{21}$$

Back substituting this into the equation for x gives $x = -\frac{34}{21}$.

So, it looks like we get a single critical point : $(-\frac{34}{21}, -\frac{25}{21})$. Also, since we know this will be a relative minimum and it is the only critical point we know that this is also the x and y coordinates of the point on the plane that we're after. We can find the z coordinate by plugging into the equation of the plane as follows,

$$z = 1 - 4\left(-\frac{34}{21}\right) + 2\left(-\frac{25}{21}\right) = \frac{107}{21}$$

So, the point on the plane that is closest to $(-2, -1, 5)$ is $(-\frac{34}{21}, -\frac{25}{21}, \frac{107}{21})$.

Absolute Minimums and Maximums

In this section we are going to extend the work from the previous section. In the previous section we were asked to find and classify all critical points as relative minimums, relative maximums and/or saddle points. In this section we want to optimize a function, that is identify the absolute minimum and/or the absolute maximum of the function, on a given region in \mathbb{R}^2 . Note that when we say we are going to be working on a region in \mathbb{R}^2 we mean that we're going to be looking at some region in the xy -plane.

In order to optimize a function in a region we are going to need to get a couple of definitions out of the way and a fact. Let's first get the definitions out of the way.

Definitions

1. A region in \mathbb{R}^2 is called **closed** if it includes its boundary. A region is called **open** if it doesn't include any of its boundary points.
2. A region in \mathbb{R}^2 is called **bounded** if it can be completely contained in a disk. In other words, a region will be bounded if it is finite.

Let's think a little more about the definition of closed. We said a region is closed if it includes its boundary. Just what does this mean? Let's think of a rectangle. Below are two definitions of a rectangle, one is closed and the other is open.

| Open | Closed |
|--------------|--------------------|
| $-5 < x < 3$ | $-5 \leq x \leq 3$ |
| $1 < y < 6$ | $1 \leq y \leq 6$ |

In this first case we don't allow the ranges to include the endpoints (*i.e.* we aren't including the edges of the rectangle) and so we aren't allowing the region to include any points on the edge of the rectangle. In other words, we aren't allowing the region to include its boundary and so it's open.

In the second case we are allowing the region to contain points on the edges and so will contain its entire boundary and hence will be closed.

This is an important idea because of the following fact.

Extreme Value Theorem

If $f(x, y)$ is continuous in some closed, bounded set D in \mathbb{R}^2 then there are points in D , (x_1, y_1) and (x_2, y_2) so that $f(x_1, y_1)$ is the absolute maximum and $f(x_2, y_2)$ is the absolute minimum of the function in D .

Note that this theorem does NOT tell us where the absolute minimum or absolute maximum will occur. It only tells us that they will exist. Note as well that the absolute minimum and/or absolute maximum may occur in the interior of the region or it may occur on the boundary of the region.

The basic process for finding absolute maximums is pretty much identical to the process that we used in Calculus I when we looked at finding [absolute extrema](#) of functions of single variables. There will however, be some procedural changes to account for the fact that we now are dealing with functions of two variables. Here is the process.

Finding Absolute Extrema

1. Find all the critical points of the function that lie in the region D and determine the function value at each of these points.
2. Find all extrema of the function on the boundary. This usually involves the Calculus I approach for this work.
3. The largest and smallest values found in the first two steps are the absolute minimum and the absolute maximum of the function.

The main difference between this process and the process that we used in Calculus I is that the “boundary” in Calculus I was just two points and so there really wasn’t a lot to do in the second step. For these problems the majority of the work is often in the second step as we will often end up doing a Calculus I absolute extrema problem one or more times.

Let’s take a look at an example or two.

Example 1 Find the absolute minimum and absolute maximum of $f(x, y) = x^2 + 4y^2 - 2x^2y + 4$ on the rectangle given by $-1 \leq x \leq 1$ and $-1 \leq y \leq 1$.

Solution

Let’s first get a quick picture of the rectangle for reference purposes.

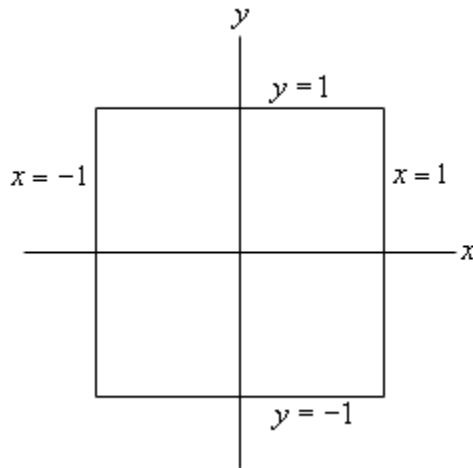

The boundary of this rectangle is given by the following conditions.

right side : $x = 1, -1 \leq y \leq 1$

left side : $x = -1, -1 \leq y \leq 1$

upper side : $y = 1, -1 \leq x \leq 1$

lower side : $y = -1, -1 \leq x \leq 1$

These will be important in the second step of our process.

We'll start this off by finding all the critical points that lie inside the given rectangle. To do this we'll need the two first order derivatives.

$$f'_x = 2x - 4xy \qquad f'_y = 8y - 2x^2$$

Note that since we aren't going to be classifying the critical points we don't need the second order derivatives. To find the critical points we will need to solve the system,

$$2x - 4xy = 0$$

$$8y - 2x^2 = 0$$

We can solve the second equation for y to get,

$$y = \frac{x^2}{4}$$

Plugging this into the first equation gives us,

$$2x - 4x\left(\frac{x^2}{4}\right) = 2x - x^3 = x(2 - x^2) = 0$$

This tells us that we must have $x = 0$ or $x = \pm\sqrt{2} = \pm 1.414\dots$. Now, recall that we only want critical points in the region that we're given. That means that we only want critical points for which $-1 \leq x \leq 1$. The only value of x that will satisfy this is the first one so we can ignore the last two for this problem. Note however that a simple change to the boundary would include these two so don't forget to always check if the critical points are in the region (or on the boundary since that can also happen).

Plugging $x = 0$ into the equation for y gives us,

$$y = \frac{0^2}{4} = 0$$

The single critical point, in the region (and again, that's important), is $(0, 0)$. We now need to get the value of the function at the critical point.

$$f(0, 0) = 4$$

Eventually we will compare this to values of the function found in the next step and take the largest and smallest as the absolute extrema of the function in the rectangle.

Now we have reached the long part of this problem. We need to find the absolute extrema of the function along the boundary of the rectangle. What this means is that we're going to need to look at what the function is doing along each of the sides of the rectangle listed above.

Let's first take a look at the right side. As noted above the right side is defined by

$$x = 1, -1 \leq y \leq 1$$

Notice that along the right side we know that $x = 1$. Let's take advantage of this by defining a new function as follows,

$$g(y) = f(1, y) = 1^2 + 4y^2 - 2(1^2)y + 4 = 5 + 4y^2 - 2y$$

Now, finding the absolute extrema of $f(x, y)$ along the right side will be equivalent to finding the absolute extrema of $g(y)$ in the range $-1 \leq y \leq 1$. Hopefully you [recall](#) how to do this from Calculus I. We find the critical points of $g(y)$ in the range $-1 \leq y \leq 1$ and then evaluate $g(y)$ at the critical points and the end points of the range of y 's.

Let's do that for this problem.

$$g'(y) = 8y - 2 \quad \Rightarrow \quad y = \frac{1}{4}$$

This is in the range and so we will need the following function evaluations.

$$g(-1) = 11 \qquad g(1) = 7 \qquad g\left(\frac{1}{4}\right) = \frac{19}{4} = 4.75$$

Notice that, using the definition of $g(y)$ these are also function values for $f(x, y)$.

$$g(-1) = f(1, -1) = 11$$

$$g(1) = f(1, 1) = 7$$

$$g\left(\frac{1}{4}\right) = f\left(1, \frac{1}{4}\right) = \frac{19}{4} = 4.75$$

We can now do the left side of the rectangle which is defined by,

$$x = -1, -1 \leq y \leq 1$$

Again, we'll define a new function as follows,

$$g(y) = f(-1, y) = (-1)^2 + 4y^2 - 2(-1)^2 y + 4 = 5 + 4y^2 - 2y$$

Notice however that, for this boundary, this is the same function as we looked at for the right side. This will not always happen, but since it has let's take advantage of the fact that we've already done the work for this function. We know that the critical point is $y = \frac{1}{4}$ and we know that the function value at the critical point and the end points are,

$$g(-1) = 11 \qquad g(1) = 7 \qquad g\left(\frac{1}{4}\right) = \frac{19}{4} = 4.75$$

The only real difference here is that these will correspond to values of $f(x, y)$ at different points

than for the right side. In this case these will correspond to the following function values for $f(x, y)$.

$$g(-1) = f(-1, -1) = 11$$

$$g(1) = f(-1, 1) = 7$$

$$g\left(\frac{1}{4}\right) = f\left(-1, \frac{1}{4}\right) = \frac{19}{4} = 4.75$$

We can now look at the upper side defined by,

$$y = 1, -1 \leq x \leq 1$$

We'll again define a new function except this time it will be a function of x .

$$h(x) = f(x, 1) = x^2 + 4(1^2) - 2x^2(1) + 4 = 8 - x^2$$

We need to find the absolute extrema of $h(x)$ on the range $-1 \leq x \leq 1$. First find the critical point(s).

$$h'(x) = -2x \quad \Rightarrow \quad x = 0$$

The value of this function at the critical point and the end points is,

$$h(-1) = 7 \quad h(1) = 7 \quad h(0) = 8$$

and these in turn correspond to the following function values for $f(x, y)$

$$h(-1) = f(-1, 1) = 7$$

$$h(1) = f(1, 1) = 7$$

$$h(0) = f(0, 1) = 8$$

Note that there are several "repeats" here. The first two function values have already been computed when we looked at the right and left side. This will often happen.

Finally, we need to take care of the lower side. This side is defined by,

$$y = -1, -1 \leq x \leq 1$$

The new function we'll define in this case is,

$$h(x) = f(x, -1) = x^2 + 4(-1)^2 - 2x^2(-1) + 4 = 8 + 3x^2$$

The critical point for this function is,

$$h'(x) = 6x \quad \Rightarrow \quad x = 0$$

The function values at the critical point and the endpoint are,

$$h(-1) = 11 \quad h(1) = 11 \quad h(0) = 8$$

and the corresponding values for $f(x, y)$ are,

$$h(-1) = f(-1, -1) = 11$$

$$h(1) = f(1, -1) = 11$$

$$h(0) = f(0, -1) = 8$$

The final step to this (long...) process is to collect up all the function values for $f(x, y)$ that we've computed in this problem. Here they are,

$$\begin{array}{lll} f(0, 0) = 4 & f(1, -1) = 11 & f(1, 1) = 7 \\ f\left(1, \frac{1}{4}\right) = 4.75 & f(-1, 1) = 7 & f(-1, -1) = 11 \\ f\left(-1, \frac{1}{4}\right) = 4.75 & f(0, 1) = 8 & f(0, -1) = 8 \end{array}$$

The absolute minimum is at $(0, 0)$ since gives the smallest function value and the absolute maximum occurs at $(1, -1)$ and $(-1, -1)$ since these two points give the largest function value.

Here is a sketch of the function on the rectangle for reference purposes.

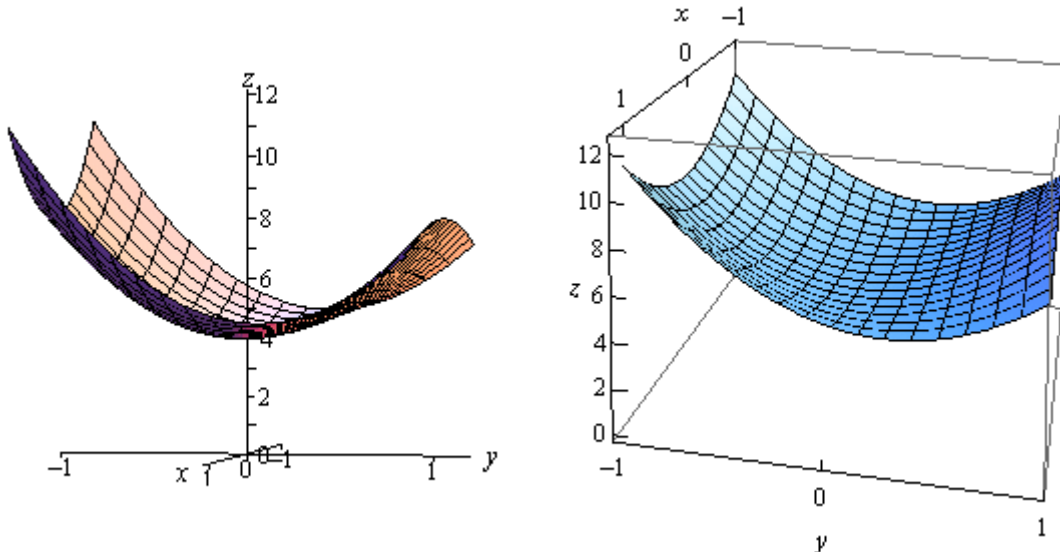

As this example has shown these can be very long problems. Let's take a look at an easier problem with a different kind of boundary.

Example 2 Find the absolute minimum and absolute maximum of $f(x, y) = 2x^2 - y^2 + 6y$ on the disk of radius 4, $x^2 + y^2 \leq 16$

Solution

First note that a disk of radius 4 is given by the inequality in the problem statement. The "less than" inequality is included to get the interior of the disk and the equal sign is included to get the

boundary. Of course, this also means that the boundary of the disk is a circle of radius 4.

Let's first find the critical points of the function that lies inside the disk. This will require the following two first order partial derivatives.

$$f_x = 4x \qquad f_y = -2y + 6$$

To find the critical points we'll need to solve the following system.

$$\begin{aligned} 4x &= 0 \\ -2y + 6 &= 0 \end{aligned}$$

This is actually a fairly simple system to solve however. The first equation tells us that $x = 0$ and the second tells us that $y = 3$. So the only critical point for this function is $(0, 3)$ and this is inside the disk of radius 4. The function value at this critical point is,

$$f(0, 3) = 9$$

Now we need to look at the boundary. This one will be somewhat different from the previous example. In this case we don't have fixed values of x and y on the boundary. Instead we have,

$$x^2 + y^2 = 16$$

We can solve this for x^2 and plug this into the x^2 in $f(x, y)$ to get a function of y as follows.

$$\begin{aligned} x^2 &= 16 - y^2 \\ g(y) &= 2(16 - y^2) - y^2 + 6y = 32 - 3y^2 + 6y \end{aligned}$$

We will need to find the absolute extrema of this function on the range $-4 \leq y \leq 4$ (this is the range of y 's for the disk....). We'll first need the critical points of this function.

$$g'(y) = -6y + 6 \quad \Rightarrow \quad y = 1$$

The value of this function at the critical point and the endpoints are,

$$g(-4) = -40 \qquad g(4) = 8 \qquad g(1) = 35$$

Unlike the first example we will still need to find the values of x that correspond to these. We can do this by plugging the value of y into our equation for the circle and solving for x .

$$\begin{aligned} y = -4 &: \quad x^2 = 16 - 16 = 0 \quad \Rightarrow \quad x = 0 \\ y = 4 &: \quad x^2 = 16 - 16 = 0 \quad \Rightarrow \quad x = 0 \\ y = 1 &: \quad x^2 = 16 - 1 = 15 \Rightarrow \quad x = \pm\sqrt{15} = \pm 3.87 \end{aligned}$$

The function values for $g(y)$ then correspond to the following function values for $f(x, y)$.

$$\begin{aligned} g(-4) = -40 &\Rightarrow f(0, -4) = -40 \\ g(4) = 8 &\Rightarrow f(0, 4) = 8 \\ g(1) = 35 &\Rightarrow f(-\sqrt{15}, 1) = 35 \quad \text{and} \quad f(\sqrt{15}, 1) = 35 \end{aligned}$$

Note that the third one actually corresponded to two different values for $f(x, y)$ since that y also produced two different values of x .

So, comparing these values to the value of the function at the critical point of $f(x, y)$ that we found earlier we can see that the absolute minimum occurs at $(0, -4)$ while the absolute maximum occurs twice at $(-\sqrt{15}, 1)$ and $(\sqrt{15}, 1)$.

Here is a sketch of the region for reference purposes.

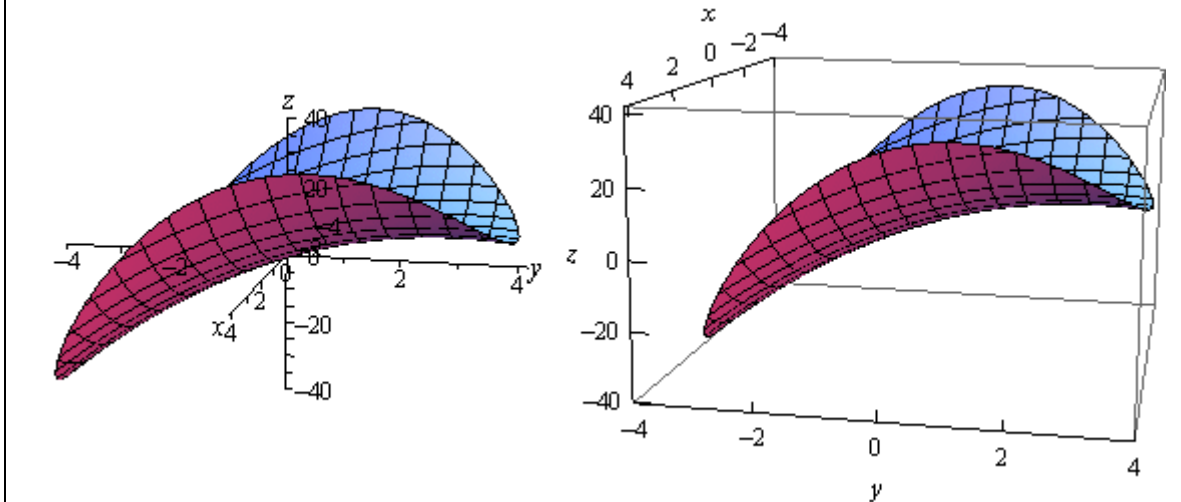

In both of these examples one of the absolute extrema actually occurred at more than one place. Sometimes this will happen and sometimes it won't so don't read too much into the fact that it happened in both examples given here.

Also note that, as we've seen, absolute extrema will often occur on the boundaries of these regions, although they don't have to occur at the boundaries. Had we given much more complicated examples with multiple critical points we would have seen examples where the absolute extrema occurred interior to the region and not on the boundary.

Lagrange Multipliers

In the previous section we optimized (*i.e.* found the absolute extrema) a function on a region that contained its boundary. Finding potential optimal points in the interior of the region isn't too bad in general, all that we needed to do was find the critical points and plug them into the function. However, as we saw in the examples finding potential optimal points on the boundary was often a fairly long and messy process.

In this section we are going to take a look at another way of optimizing a function subject to given constraint(s). The constraint(s) may be the equation(s) that describe the boundary of a region although in this section we won't concentrate on those types of problems since this method just requires a general constraint and doesn't really care where the constraint came from.

So, let's get things set up. We want to optimize (find the minimum and maximum) of a function, $f(x, y, z)$, subject to the constraint $g(x, y, z) = k$. Again, the constraint may be the equation that describes the boundary of a region or it may not be. The process is actually fairly simple, although the work can still be a little overwhelming at times.

Method of Lagrange Multipliers

1. Solve the following system of equations.

$$\begin{aligned}\nabla f(x, y, z) &= \lambda \nabla g(x, y, z) \\ g(x, y, z) &= k\end{aligned}$$

2. Plug in all solutions, (x, y, z) , from the first step into $f(x, y, z)$ and identify the minimum and maximum values, provided they exist.

The constant, λ , is called the **Lagrange Multiplier**.

Notice that the system of equations actually has four equations, we just wrote the system in a simpler form. To see this let's take the first equation and put in the definition of the gradient vector to see what we get.

$$\langle f_x, f_y, f_z \rangle = \lambda \langle g_x, g_y, g_z \rangle = \langle \lambda g_x, \lambda g_y, \lambda g_z \rangle$$

In order for these two vectors to be equal the individual components must also be equal. So, we actually have three equations here.

$$f_x = \lambda g_x \quad f_y = \lambda g_y \quad f_z = \lambda g_z$$

These three equations along with the constraint, $g(x, y, z) = c$, give four equations with four unknowns x, y, z , and λ .

Note as well that if we only have functions of two variables then we won't have the third component of the gradient and so will only have three equations in three unknowns x, y , and λ .

As a final note we also need to be careful with the fact that in some cases minimums and maximums won't exist even though the method will seem to imply that they do. In every problem we'll need to go back and make sure that our answers make sense.

Let's work a couple of examples.

Example 1 Find the dimensions of the box with largest volume if the total surface area is 64 cm².

Solution

Before we start the process here note that we also saw a way to solve this kind of problem in [Calculus I](#), except in those problems we required a condition that related one of the sides of the box to the other sides so that we could get down to a volume and surface area function that only involved two variables. We no longer need this condition for these problems.

Now, let's get on to solving the problem. We first need to identify the function that we're going to optimize as well as the constraint. Let's set the length of the box to be x , the width of the box to be y and the height of the box to be z . Let's also note that because we're dealing with the dimensions of a box it is safe to assume that x , y , and z are all positive quantities.

We want to find the largest volume and so the function that we want to optimize is given by,

$$f(x, y, z) = xyz$$

Next we know that the surface area of the box must be a constant 64. So this is the constraint. The surface area of a box is simply the sum of the areas of each of the sides so the constraint is given by,

$$2xy + 2xz + 2yz = 64 \quad \Rightarrow \quad xy + xz + yz = 32$$

Note that we divided the constraint by 2 to simplify the equation a little. Also, we get the function $g(x, y, z)$ from this.

$$g(x, y, z) = xy + xz + yz$$

Here are the four equations that we need to solve.

$$yz = \lambda(y + z) \quad (f_x = \lambda g_x) \quad (1)$$

$$xz = \lambda(x + z) \quad (f_y = \lambda g_y) \quad (2)$$

$$xy = \lambda(x + y) \quad (f_z = \lambda g_z) \quad (3)$$

$$xy + xz + yz = 32 \quad (g(x, y, z) = 32) \quad (4)$$

There are many ways to solve this system. We'll solve it in the following way. Let's multiply equation (1) by x , equation (2) by y and equation (3) by z . This gives,

$$xyz = \lambda x(y + z) \quad (5)$$

$$xyz = \lambda y(x + z) \quad (6)$$

$$xyz = \lambda z(x + y) \quad (7)$$

Now notice that we can set equations (5) and (6) equal. Doing this gives,

$$\begin{aligned}\lambda x(y+z) &= \lambda y(x+z) \\ \lambda(xy+xz) - \lambda(yx+yz) &= 0 \\ \lambda(xz-yz) &= 0 \quad \Rightarrow \quad \lambda = 0 \quad \text{or} \quad xz = yz\end{aligned}$$

This gave two possibilities. The first, $\lambda = 0$ is not possible since if this was the case equation (1) would reduce to

$$yz = 0 \quad \Rightarrow \quad y = 0 \quad \text{or} \quad z = 0$$

Since we are talking about the dimensions of a box neither of these are possible so we can discount $\lambda = 0$. This leaves the second possibility.

$$xz = yz$$

Since we know that $z \neq 0$ (again since we are talking about the dimensions of a box) we can cancel the z from both sides. This gives,

$$x = y \tag{8}$$

Next, let's set equations (6) and (7) equal. Doing this gives,

$$\begin{aligned}\lambda y(x+z) &= \lambda z(x+y) \\ \lambda(yx+yz-zx-zy) &= 0 \\ \lambda(yx-zx) &= 0 \quad \Rightarrow \quad \lambda = 0 \quad \text{or} \quad yx = zx\end{aligned}$$

As already discussed we know that $\lambda = 0$ won't work and so this leaves,

$$yx = zx$$

We can also say that $x \neq 0$ since we are dealing with the dimensions of a box so we must have,

$$z = y \tag{9}$$

Plugging equations (8) and (9) into equation (4) we get,

$$y^2 + y^2 + y^2 = 3y^2 = 32 \quad y = \pm \sqrt{\frac{32}{3}} = \pm 3.266$$

However, we know that y must be positive since we are talking about the dimensions of a box. Therefore the only solution that makes physical sense here is

$$x = y = z = 3.266$$

So, it looks like we've got a cube here.

We should be a little careful here. Since we've only got one solution we might be tempted to assume that these are the dimensions that will give the largest volume. The method of Lagrange Multipliers will give a set of points that will either maximize or minimize a given function subject to the constraint, provided there actually are minimums or maximums.

The function itself, $f(x, y, z) = xyz$ will clearly have neither minimums or maximums unless we put some restrictions on the variables. The only real restriction that we've got is that all the variables must be positive. This, of course, instantly means that the function does have a

minimum, zero.

The function will not have a maximum if all the variables are allowed to increase without bound. That however, can't happen because of the constraint,

$$xy + xz + yz = 32$$

Here we've got the sum of three positive numbers (because x , y , and z are positive) and the sum must equal 32. So, if one of the variables gets very large, say x , then because each of the products must be less than 32 both y and z must be very small to make sure the first two terms are less than 32. So, there is no way for all the variables to increase without bound and so it should make some sense that the function, $f(x, y, z) = xyz$, will have a maximum.

This isn't a rigorous proof that the function will have a maximum, but it should help to visualize that in fact it should have a maximum and so we can say that we will get a maximum volume if the dimensions are : $x = y = z = 3.266$.

Notice that we never actually found values for λ in the above example. This is fairly standard for these kinds of problems. The value of λ isn't really important to determining if the point is a maximum or a minimum so often we will not bother with finding a value for it. On occasion we will need its value to help solve the system, but even in those cases we won't use it past finding the point.

Example 2 Find the maximum and minimum of $f(x, y) = 5x - 3y$ subject to the constraint $x^2 + y^2 = 136$.

Solution

This one is going to be a little easier than the previous one since it only has two variables. Also, note that it's clear from the constraint that region of possible solutions lies on a disk of radius $\sqrt{136}$ which is a closed and bounded region and hence by the [Extreme Value Theorem](#) we know that a minimum and maximum value must exist.

Here is the system that we need to solve.

$$\begin{aligned} 5 &= 2\lambda x \\ -3 &= 2\lambda y \\ x^2 + y^2 &= 136 \end{aligned}$$

Notice that, as with the last example, we can't have $\lambda = 0$ since that would not satisfy the first two equations. So, since we know that $\lambda \neq 0$ we can solve the first two equations for x and y respectively. This gives,

$$x = \frac{5}{2\lambda} \qquad y = -\frac{3}{2\lambda}$$

Plugging these into the constraint gives,

$$\frac{25}{4\lambda^2} + \frac{9}{4\lambda^2} = \frac{17}{2\lambda^2} = 136$$

We can solve this for λ .

$$\lambda^2 = \frac{1}{16} \quad \Rightarrow \quad \lambda = \pm \frac{1}{4}$$

Now, that we know λ we can find the points that will be potential maximums and/or minimums.

If $\lambda = -\frac{1}{4}$ we get,

$$x = -10 \qquad y = 6$$

and if $\lambda = \frac{1}{4}$ we get,

$$x = 10 \qquad y = -6$$

To determine if we have maximums or minimums we just need to plug these into the function. Also recall from the discussion at the start of this solution that we know these will be the minimum and maximums because the Extreme Value Theorem tells us that minimums and maximums will exist for this problem.

Here are the minimum and maximum values of the function.

$$f(-10, 6) = -68 \qquad \text{Minimum at } (-10, 6)$$

$$f(10, -6) = 68 \qquad \text{Maximum at } (10, -6)$$

In the first two examples we've excluded $\lambda = 0$ either for physical reasons or because it wouldn't solve one or more of the equations. Do not always expect this to happen. Sometimes we will be able to automatically exclude a value of λ and sometimes we won't.

Let's take a look at another example.

Example 3 Find the maximum and minimum values of $f(x, y, z) = xyz$ subject to the constraint $x + y + z = 1$. Assume that $x, y, z \geq 0$.

Solution

First note that our constraint is a sum of three positive or zero number and it must be 1. Therefore it is clear that our solution will fall in the range $0 \leq x, y, z \leq 1$. Therefore the solution must lie in a closed and bounded region and so by the [Extreme Value Theorem](#) we know that a minimum and maximum value must exist.

Here is the system of equation that we need to solve.

$$yz = \lambda \qquad (10)$$

$$xz = \lambda \qquad (11)$$

$$xy = \lambda \qquad (12)$$

$$x + y + z = 1 \qquad (13)$$

Let's start this solution process off by noticing that since the first three equations all have λ they are all equal. So, let's start off by setting equations (10) and (11) equal.

$$yz = xz \quad \Rightarrow \quad z(y - x) = 0 \quad \Rightarrow \quad z = 0 \text{ or } y = x$$

So, we've got two possibilities here. Let's start off with by assuming that $z = 0$. In this case we can see from either equation (10) or (11) that we must then have $\lambda = 0$. From equation (12) we see that this means that $xy = 0$. This in turn means that either $x = 0$ or $y = 0$.

So, we've got two possible cases to deal with there. In each case two of the variables must be zero. Once we know this we can plug into the constraint, equation (13), to find the remaining value.

$$z = 0, x = 0: \quad \Rightarrow \quad y = 1$$

$$z = 0, y = 0: \quad \Rightarrow \quad x = 1$$

So, we've got two possible solutions $(0,1,0)$ and $(1,0,0)$.

Now let's go back and take a look at the other possibility, $y = x$. We also have two possible cases to look at here as well.

This first case is $x = y = 0$. In this case we can see from the constraint that we must have $z = 1$ and so we now have a third solution $(0,0,1)$.

The second case is $x = y \neq 0$. Let's set equations (11) and (12) equal.

$$xz = xy \quad \Rightarrow \quad x(z - y) = 0 \quad \Rightarrow \quad x = 0 \text{ or } z = y$$

Now, we've already assumed that $x \neq 0$ and so the only possibility is that $z = y$. However, this also means that,

$$x = y = z$$

Using this in the constraint gives,

$$3x = 1 \quad \Rightarrow \quad x = \frac{1}{3}$$

So, the next solution is $\left(\frac{1}{3}, \frac{1}{3}, \frac{1}{3}\right)$.

We got four solutions by setting the first two equations equal.

To completely finish this problem out we should probably set equations (10) and (12) equal as well as setting equations (11) and (12) equal to see what we get. Doing this gives,

$$yz = xy \quad \Rightarrow \quad y(z - x) = 0 \quad \Rightarrow \quad y = 0 \text{ or } z = x$$

$$xz = xy \quad \Rightarrow \quad x(z - y) = 0 \quad \Rightarrow \quad x = 0 \text{ or } z = y$$

Both of these are very similar to the first situation that we looked at and we'll leave it up to you to show that in each of these cases we arrive back at the four solutions that we already found.

So, we have four solutions that we need to check in the function to see whether we have minimums or maximums.

$$f(0,0,1) = 0 \quad f(0,1,0) = 0 \quad f(1,0,0) = 0 \quad \text{All Minimums}$$

$$f\left(\frac{1}{3}, \frac{1}{3}, \frac{1}{3}\right) = \frac{1}{27} \quad \text{Maximum}$$

So, in this case the maximum occurs only once while the minimum occurs three times.

Note as well that we never really used the assumption that $x, y, z \geq 0$ in this problem. This assumption is here mostly to make sure that we really do have a maximum and a minimum of the function. Without this assumption it wouldn't be too difficult to find points that give both larger and smaller values of the functions. For example.

$$x = -100, y = 100, z = 1: -100 + 100 + 1 = 1 \quad f(-100, 100, 1) = -10000$$

$$x = -50, y = -50, z = 101: -50 - 50 + 101 = 1 \quad f(-50, -50, 101) = 252500$$

With these examples you can clearly see that it's not too hard to find points that will give larger and smaller function values. However, all of these examples required negative values of x, y and/or z to make sure we satisfy the constraint. By eliminating these we will know that we've got minimum and maximum values by the Extreme Value Theorem.

To this point we've only looked at constraints that were equations. We can also have constraints that are inequalities. The process for these types of problems is nearly identical to what we've been doing in this section to this point. The main difference between the two types of problems is that we will also need to find all the critical points that satisfy the inequality in the constraint and check these in the function when we check the values we found using Lagrange Multipliers.

Let's work an example to see how these kinds of problems work.

Example 4 Find the maximum and minimum values of $f(x, y) = 4x^2 + 10y^2$ on the disk $x^2 + y^2 \leq 4$.

Solution

Note that the constraint here is the inequality for the disk. Because this is a closed and bounded region the [Extreme Value Theorem](#) tells us that a minimum and maximum value must exist.

The first step is to find all the critical points that are in the disk (*i.e.* satisfy the constraint). This is easy enough to do for this problem. Here are the two first order partial derivatives.

$$\begin{aligned} f_x = 8x &\Rightarrow 8x = 0 &\Rightarrow x = 0 \\ f_y = 20y &\Rightarrow 20y = 0 &\Rightarrow y = 0 \end{aligned}$$

So, the only critical point is $(0, 0)$ and it does satisfy the inequality.

At this point we proceed with Lagrange Multipliers and we treat the constraint as an equality instead of the inequality. We only need to deal with the inequality when finding the critical points.

So, here is the system of equations that we need to solve.

$$\begin{aligned} 8x &= 2\lambda x \\ 20y &= 2\lambda y \\ x^2 + y^2 &= 4 \end{aligned}$$

From the first equation we get,

$$2x(4 - \lambda) = 0 \quad \Rightarrow \quad x = 0 \quad \text{or} \quad \lambda = 4$$

If we have $x = 0$ then the constraint gives us $y = \pm 2$.

If we have $\lambda = 4$ the second equation gives us,

$$20y = 8y \quad \Rightarrow \quad y = 0$$

The constraint then tells us that $x = \pm 2$.

If we'd performed a similar analysis on the second equation we would arrive at the same points.

So, Lagrange Multipliers gives us four points to check : $(0, 2)$, $(0, -2)$, $(2, 0)$, and $(-2, 0)$.

To find the maximum and minimum we need to simply plug these four points along with the critical point in the function.

$$\begin{aligned} f(0, 0) &= 0 && \text{Minimum} \\ f(2, 0) &= f(-2, 0) = 16 \\ f(0, 2) &= f(0, -2) = 40 && \text{Maximum} \end{aligned}$$

In this case, the minimum was interior to the disk and the maximum was on the boundary of the disk.

The final topic that we need to discuss in this section is what to do if we have more than one constraint. We will look only at two constraints, but we can naturally extend the work here to more than two constraints.

We want to optimize $f(x, y, z)$ subject to the constraints $g(x, y, z) = c$ and $h(x, y, z) = k$.

The system that we need to solve in this case is,

$$\begin{aligned} \nabla f(x, y, z) &= \lambda \nabla g(x, y, z) + \mu \nabla h(x, y, z) \\ g(x, y, z) &= c \\ h(x, y, z) &= k \end{aligned}$$

So, in this case we get two Lagrange Multipliers. Also, note that the first equation really is three equations as we saw in the previous examples. Let's see an example of this kind of optimization problem.

Example 5 Find the maximum and minimum of $f(x, y, z) = 4y - 2z$ subject to the constraints $2x - y - z = 2$ and $x^2 + y^2 = 1$.

Solution

Verifying that we will have a minimum and maximum value here is a little trickier. Clearly, because of the second constraint we've got to have $-1 \leq x, y \leq 1$. With this in mind there must also be a set of limits on z in order to make sure that the first constraint is met. If one really wanted to determine that range you could find the minimum and maximum values of $2x - y$ subject to $x^2 + y^2 = 1$ and you could then use this to determine the minimum and maximum values of z . We won't do that here. The point is only to acknowledge that once again the possible solutions must lie in a closed and bounded region and so minimum and maximum values must exist by the [Extreme Value Theorem](#).

Here is the system of equations that we need to solve.

$$0 = 2\lambda + 2\mu x \quad (f_x = \lambda g_x + \mu h_x) \quad (14)$$

$$4 = -\lambda + 2\mu y \quad (f_y = \lambda g_y + \mu h_y) \quad (15)$$

$$-2 = -\lambda \quad (f_z = \lambda g_z + \mu h_z) \quad (16)$$

$$2x - y - z = 2 \quad (17)$$

$$x^2 + y^2 = 1 \quad (18)$$

First, let's notice that from equation (16) we get $\lambda = 2$. Plugging this into equation (14) and equation (15) and solving for x and y respectively gives,

$$0 = 4 + 2\mu x \quad \Rightarrow \quad x = -\frac{2}{\mu}$$

$$4 = -2 + 2\mu y \quad \Rightarrow \quad y = \frac{3}{\mu}$$

Now, plug these into equation (18).

$$\frac{4}{\mu^2} + \frac{9}{\mu^2} = \frac{13}{\mu^2} = 1 \quad \Rightarrow \quad \mu = \pm\sqrt{13}$$

So, we have two cases to look at here. First, let's see what we get when $\mu = \sqrt{13}$. In this case we know that,

$$x = -\frac{2}{\sqrt{13}} \quad y = \frac{3}{\sqrt{13}}$$

Plugging these into equation (17) gives,

$$-\frac{4}{\sqrt{13}} - \frac{3}{\sqrt{13}} - z = 2 \quad \Rightarrow \quad z = -2 - \frac{7}{\sqrt{13}}$$

So, we've got one solution.

Let's now see what we get if we take $\mu = -\sqrt{13}$. Here we have,

$$x = \frac{2}{\sqrt{13}} \quad y = -\frac{3}{\sqrt{13}}$$

Plugging these into equation (17) gives,

$$\frac{4}{\sqrt{13}} + \frac{3}{\sqrt{13}} - z = 2 \quad \Rightarrow \quad z = -2 + \frac{7}{\sqrt{13}}$$

and there's a second solution.

Now all that we need to is check the two solutions in the function to see which is the maximum and which is the minimum.

$$f\left(-\frac{2}{\sqrt{13}}, \frac{3}{\sqrt{13}}, -2 - \frac{7}{\sqrt{13}}\right) = 4 + \frac{26}{\sqrt{13}} = 11.2111$$

$$f\left(\frac{2}{\sqrt{13}}, -\frac{3}{\sqrt{13}}, -2 + \frac{7}{\sqrt{13}}\right) = 4 - \frac{26}{\sqrt{13}} = -3.2111$$

So, we have a maximum at $\left(-\frac{2}{\sqrt{13}}, \frac{3}{\sqrt{13}}, -2 - \frac{7}{\sqrt{13}}\right)$ and a minimum at $\left(\frac{2}{\sqrt{13}}, -\frac{3}{\sqrt{13}}, -2 + \frac{7}{\sqrt{13}}\right)$.

Multiple Integrals

Introduction

In Calculus I we moved on to the subject of integrals once we had finished the discussion of derivatives. The same is true in this course. Now that we have finished our discussion of derivatives of functions of more than one variable we need to move on to integrals of functions of two or three variables.

Most of the derivatives topics extended somewhat naturally from their Calculus I counterparts and that will be the same here. However, because we are now involving functions of two or three variables there will be some differences as well. There will be new notation and some new issues that simply don't arise when dealing with functions of a single variable.

Here is a list of topics covered in this chapter.

[Double Integrals](#) – We will define the double integral in this section.

[Iterated Integrals](#) – In this section we will start looking at how we actually compute double integrals.

[Double Integrals over General Regions](#) – Here we will look at some general double integrals.

[Double Integrals in Polar Coordinates](#) – In this section we will take a look at evaluating double integrals using polar coordinates.

[Triple Integrals](#) – Here we will define the triple integral as well as how we evaluate them.

[Triple Integrals in Cylindrical Coordinates](#) – We will evaluate triple integrals using cylindrical coordinates in this section.

[Triple Integrals in Spherical Coordinates](#) – In this section we will evaluate triple integrals using spherical coordinates.

[Change of Variables](#) – In this section we will look at change of variables for double and triple integrals.

[Surface Area](#) – Here we look at the one real application of double integrals that we're going to look at in this material.

[Area and Volume Revisited](#) – We summarize the area and volume formulas from this chapter.

Double Integrals

Before starting on double integrals let's do a quick review of the definition of a definite integrals for functions of single variables. First, when working with the integral,

$$\int_a^b f(x) dx$$

we think of x 's as coming from the interval $a \leq x \leq b$. For these integrals we can say that we are integrating over the interval $a \leq x \leq b$. Note that this does assume that $a < b$, however, if we have $b < a$ then we can just use the interval $b \leq x \leq a$.

Now, when we [derived](#) the definition of the definite integral we first thought of this as an area problem. We first asked what the area under the curve was and to do this we broke up the interval $a \leq x \leq b$ into n subintervals of width Δx and choose a point, x_i^* , from each interval as shown below,

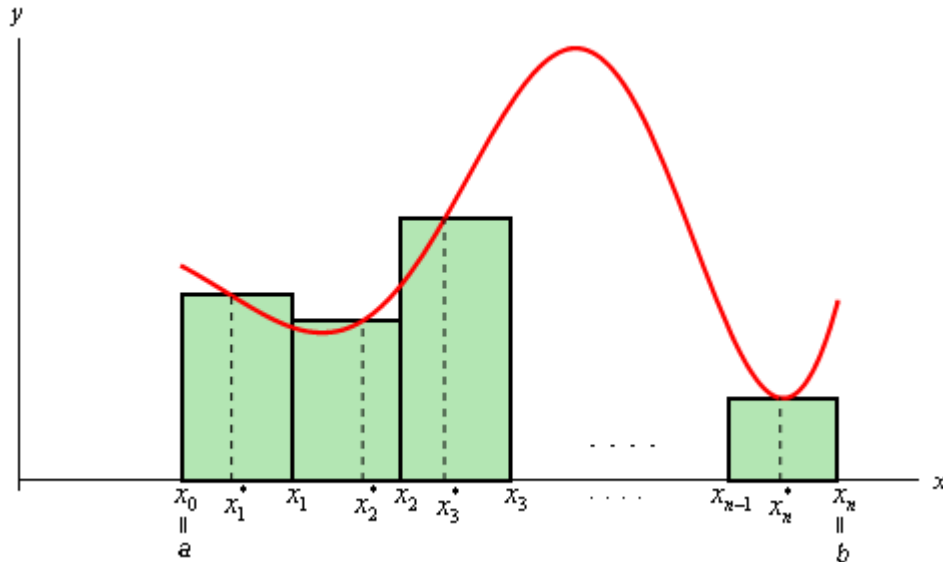

Each of the rectangles has height of $f(x_i^*)$ and we could then use the area of each of these rectangles to approximate the area as follows.

$$A \approx f(x_1^*)\Delta x + f(x_2^*)\Delta x + \cdots + f(x_i^*)\Delta x + \cdots + f(x_n^*)\Delta x$$

To get the exact area we then took the limit as n goes to infinity and this was also the definition of the definite integral.

$$\int_a^b f(x) dx = \lim_{n \rightarrow \infty} \sum_{i=1}^n f(x_i^*) \Delta x$$

In this section we want to integrate a function of two variables, $f(x, y)$. With functions of one variable we integrated over an interval (*i.e.* a one-dimensional space) and so it makes some sense then that when integrating a function of two variables we will integrate over a region of \mathbb{R}^2 (two-dimensional space).

We will start out by assuming that the region in \mathbb{R}^2 is a rectangle which we will denote as follows,

$$R = [a, b] \times [c, d]$$

This means that the ranges for x and y are $a \leq x \leq b$ and $c \leq y \leq d$.

Also, we will initially assume that $f(x, y) \geq 0$ although this doesn't really have to be the case.

Let's start out with the graph of the surface S given by graphing $f(x, y)$ over the rectangle R .

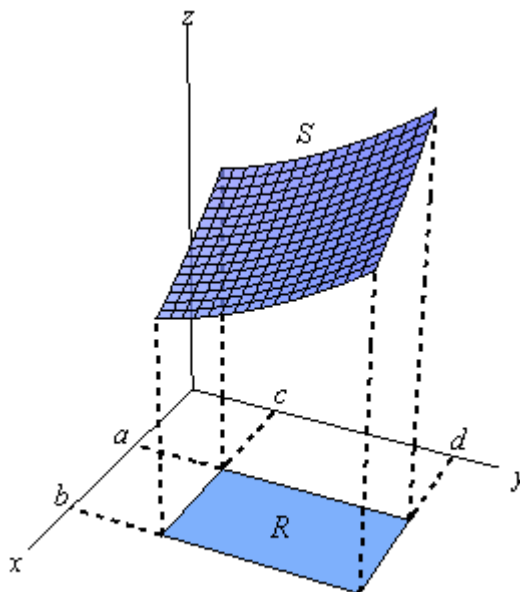

Now, just like with functions of one variable let's not worry about integrals quite yet. Let's first ask what the volume of the region under S (and above the xy -plane of course) is.

We will first approximate the volume much as we approximated the area above. We will first divide up $a \leq x \leq b$ into n subintervals and divide up $c \leq y \leq d$ into m subintervals. This will divide up R into a series of smaller rectangles and from each of these we will choose a point (x_i^*, y_j^*) . Here is a sketch of this set up.

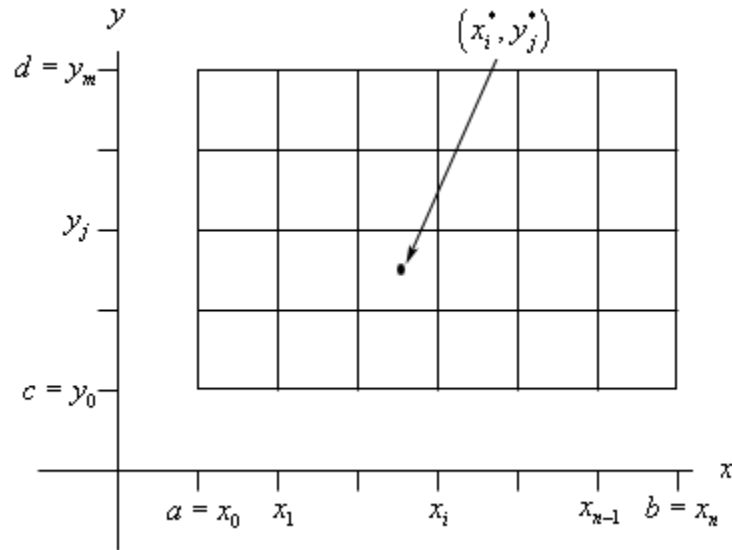

Now, over each of these smaller rectangles we will construct a box whose height is given by $f(x_i^*, y_j^*)$. Here is a sketch of that.

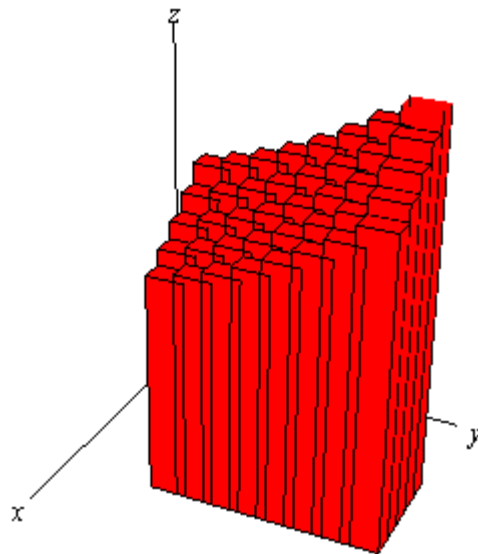

Each of the rectangles has a base area of ΔA and a height of $f(x_i^*, y_j^*)$ so the volume of each of these boxes is $f(x_i^*, y_j^*)\Delta A$. The volume under the surface S is then approximately,

$$V \approx \sum_{i=1}^n \sum_{j=1}^m f(x_i^*, y_j^*)\Delta A$$

We will have a *double* sum since we will need to add up volumes in both the x and y directions.

To get a better estimation of the volume we will take n and m larger and larger and to get the exact volume we will need to take the limit as both n and m go to infinity. In other words,

$$V = \lim_{n, m \rightarrow \infty} \sum_{i=1}^n \sum_{j=1}^m f(x_i^*, y_j^*) \Delta A$$

Now, this should look familiar. This looks a lot like the definition of the integral of a function of single variable. In fact this is also the definition of a double integral, or more exactly an integral of a function of two variables over a rectangle.

Here is the official definition of a double integral of a function of two variables over a rectangular region R as well as the notation that we'll use for it.

$$\iint_R f(x, y) dA = \lim_{n, m \rightarrow \infty} \sum_{i=1}^n \sum_{j=1}^m f(x_i^*, y_j^*) \Delta A$$

Note the similarities and differences in the notation to single integrals. We have two integrals to denote the fact that we are dealing with a two dimensional region and we have a differential here as well. Note that the differential is dA instead of the dx and dy that we're used to seeing. Note as well that we don't have limits on the integrals in this notation. Instead we have the R written below the two integrals to denote the region that we are integrating over.

Note that one interpretation of the double integral of $f(x, y)$ over the rectangle R is the volume under the function $f(x, y)$ (and above the xy -plane). Or,

$$\text{Volume} = \iint_R f(x, y) dA$$

We can use this double sum in the definition to estimate the value of a double integral if we need to. We can do this by choosing (x_i^*, y_j^*) to be the midpoint of each rectangle. When we do this we usually denote the point as (\bar{x}_i, \bar{y}_j) . This leads to the **Midpoint Rule**,

$$\iint_R f(x, y) dA \approx \sum_{i=1}^n \sum_{j=1}^m f(\bar{x}_i, \bar{y}_j) \Delta A$$

In the next section we start looking at how to actually compute double integrals.

Iterated Integrals

In the previous section we gave the definition of the double integral. However, just like with the definition of a single integral the definition is very difficult to use in practice and so we need to start looking into how we actually compute double integrals. We will continue to assume that we are integrating over the rectangle

$$R = [a, b] \times [c, d]$$

We will look at more general regions in the next section.

The following theorem tells us how to compute a double integral over a rectangle.

Fubini's Theorem

If $f(x, y)$ is continuous on $R = [a, b] \times [c, d]$ then,

$$\iint_R f(x, y) dA = \int_a^b \int_c^d f(x, y) dy dx = \int_c^d \int_a^b f(x, y) dx dy$$

These integrals are called **iterated integrals**.

Note that there are in fact two ways of computing a double integral and also notice that the inner differential matches up with the limits on the inner integral and similarly for the outer differential and limits. In other words, if the inner differential is dy then the limits on the inner integral must be y limits of integration and if the outer differential is dx then the limits on the outer integral must be x limits of integration.

Now, on some level this is just notation and doesn't really tell us how to compute the double integral. Let's just take the first possibility above and change the notation a little.

$$\iint_R f(x, y) dA = \int_a^b \left[\int_c^d f(x, y) dy \right] dx$$

We will compute the double integral by first computing

$$\int_c^d f(x, y) dy$$

and we compute this by holding x constant and integrating with respect to y as if this were an single integral. This will give a function involving only x 's which we can in turn integrate.

We've done a similar process with partial derivatives. To take the derivative of a function with respect to y we treated the x 's as constants and differentiated with respect to y as if it was a function of a single variable.

Double integrals work in the same manner. We think of all the x 's as constants and integrate with respect to y or we think of all y 's as constants and integrate with respect to x .

Let's take a look at some examples.

Example 1 Compute each of the following double integrals over the indicated rectangles.

(a) $\iint_R 6xy^2 dA$, $R = [2, 4] \times [1, 2]$ [Solution]

(b) $\iint_R 2x - 4y^3 dA$, $R = [-5, 4] \times [0, 3]$ [Solution]

(c) $\iint_R x^2 y^2 + \cos(\pi x) + \sin(\pi y) dA$, $R = [-2, -1] \times [0, 1]$ [Solution]

(d) $\iint_R \frac{1}{(2x+3y)^2} dA$, $R = [0, 1] \times [1, 2]$ [Solution]

(e) $\iint_R xe^{xy} dA$, $R = [-1, 2] \times [0, 1]$ [Solution]

Solution

(a) $\iint_R 6xy^2 dA$, $R = [2, 4] \times [1, 2]$

It doesn't matter which variable we integrate with respect to first, we will get the same answer regardless of the order of integration. To prove that let's work this one with each order to make sure that we do get the same answer.

Solution 1

In this case we will integrate with respect to y first. So, the iterated integral that we need to compute is,

$$\iint_R 6xy^2 dA = \int_2^4 \int_1^2 6xy^2 dy dx$$

When setting these up make sure the limits match up to the differentials. Since the dy is the inner differential (*i.e.* we are integrating with respect to y first) the inner integral needs to have y limits.

To compute this we will do the inner integral first and we typically keep the outer integral around as follows,

$$\begin{aligned} \iint_R 6xy^2 dA &= \int_2^4 (2xy^3) \Big|_1^2 dx \\ &= \int_2^4 16x - 2x dx \\ &= \int_2^4 14x dx \end{aligned}$$

Remember that we treat the x as a constant when doing the first integral and we don't do any integration with it yet. Now, we have a normal single integral so let's finish the integral by computing this.

$$\iint_R 6xy^2 dA = 7x^2 \Big|_2^4 = 84$$

Solution 2

In this case we'll integrate with respect to x first and then y . Here is the work for this solution.

$$\begin{aligned}\iint_R 6xy^2 dA &= \int_1^2 \int_2^4 6xy^2 dx dy \\ &= \int_1^2 (3x^2y^2) \Big|_2^4 dy \\ &= \int_1^2 36y^2 dy \\ &= 12y^3 \Big|_1^2 \\ &= 84\end{aligned}$$

Sure enough the same answer as the first solution.

So, remember that we can do the integration in any order.

[\[Return to Problems\]](#)

(b) $\iint_R 2x - 4y^3 dA$, $R = [-5, 4] \times [0, 3]$

For this integral we'll integrate with respect to y first.

$$\begin{aligned}\iint_R 2x - 4y^3 dA &= \int_{-5}^4 \int_0^3 2x - 4y^3 dy dx \\ &= \int_{-5}^4 (2xy - y^4) \Big|_0^3 dx \\ &= \int_{-5}^4 6x - 81 dx \\ &= (3x^2 - 81x) \Big|_{-5}^4 \\ &= -756\end{aligned}$$

Remember that when integrating with respect to y all x 's are treated as constants and so as far as the inner integral is concerned the $2x$ is a constant and we know that when we integrate constants with respect to y we just tack on a y and so we get $2xy$ from the first term.

[\[Return to Problems\]](#)

(c) $\iint_R x^2 y^2 + \cos(\pi x) + \sin(\pi y) dA$, $R = [-2, -1] \times [0, 1]$

In this case we'll integrate with respect to x first.

$$\begin{aligned}
\iint_R x^2 y^2 + \cos(\pi x) + \sin(\pi y) dA &= \int_0^1 \int_{-2}^{-1} x^2 y^2 + \cos(\pi x) + \sin(\pi y) dx dy \\
&= \int_0^1 \left(\frac{1}{3} x^3 y^2 + \frac{1}{\pi} \sin(\pi x) + x \sin(\pi y) \right) \Big|_{-2}^{-1} dy \\
&= \int_0^1 \frac{7}{3} y^2 + \sin(\pi y) dy \\
&= \frac{7}{9} y^3 - \frac{1}{\pi} \cos(\pi y) \Big|_0^1 \\
&= \frac{7}{9} + \frac{2}{\pi}
\end{aligned}$$

Don't forget your basic Calculus I [substitutions](#)!

[\[Return to Problems\]](#)

(d) $\iint_R \frac{1}{(2x+3y)^2} dA, R = [0,1] \times [1,2]$

In this case because the limits for x are kind of nice (*i.e.* they are zero and one which are often nice for evaluation) let's integrate with respect to x first. We'll also rewrite the integrand to help with the first integration.

$$\begin{aligned}
\iint_R (2x+3y)^{-2} dA &= \int_1^2 \int_0^1 (2x+3y)^{-2} dx dy \\
&= \int_1^2 \left(-\frac{1}{2} (2x+3y)^{-1} \right) \Big|_0^1 dy \\
&= -\frac{1}{2} \int_1^2 \frac{1}{2+3y} - \frac{1}{3y} dy \\
&= -\frac{1}{2} \left(\frac{1}{3} \ln|2+3y| - \frac{1}{3} \ln|y| \right) \Big|_1^2 \\
&= -\frac{1}{6} (\ln 8 - \ln 2 - \ln 5)
\end{aligned}$$

[\[Return to Problems\]](#)

(e) $\iint_R x e^{xy} dA, R = [-1,2] \times [0,1]$

Now, while we can technically integrate with respect to either variable first sometimes one way is significantly easier than the other way. In this case it will be significantly easier to integrate with respect to y first as we will see.

$$\iint_R x e^{xy} dA = \int_{-1}^2 \int_0^1 x e^{xy} dy dx$$

The y integration can be done with the quick substitution,

$$u = xy \quad du = x dy$$

which gives

$$\begin{aligned} \iint_R x e^{xy} dA &= \int_{-1}^2 e^{xy} \Big|_0^1 dx \\ &= \int_{-1}^2 e^x - 1 dx \\ &= (e^x - x) \Big|_{-1}^2 \\ &= e^2 - 2 - (e^{-1} + 1) \\ &= e^2 - e^{-1} - 3 \end{aligned}$$

So, not too bad of an integral there provided you get the substitution. Now let's see what would happen if we had integrated with respect to x first.

$$\iint_R x e^{xy} dA = \int_0^1 \int_{-1}^2 x e^{xy} dx dy$$

In order to do this we would have to use integration by parts as follows,

$$\begin{aligned} u &= x & dv &= e^{xy} dx \\ du &= dx & v &= \frac{1}{y} e^{xy} \end{aligned}$$

The integral is then,

$$\begin{aligned} \iint_R x e^{xy} dA &= \int_0^1 \left(\frac{x}{y} e^{xy} - \int \frac{1}{y} e^{xy} dx \right) \Big|_{-1}^2 dy \\ &= \int_0^1 \left(\frac{x}{y} e^{xy} - \frac{1}{y^2} e^{xy} \right) \Big|_{-1}^2 dy \\ &= \int_0^1 \left(\frac{2}{y} e^{2y} - \frac{1}{y^2} e^{2y} \right) - \left(-\frac{1}{y} e^{-y} - \frac{1}{y^2} e^{-y} \right) dy \end{aligned}$$

We're not even going to continue here as these are very difficult integrals to do.

[\[Return to Problems\]](#)

As we saw in the previous set of examples we can do the integral in either direction. However, sometimes one direction of integration is significantly easier than the other so make sure that you think about which one you should do first before actually doing the integral.

The next topic of this section is a quick fact that can be used to make some iterated integrals somewhat easier to compute on occasion.

Fact

If $f(x, y) = g(x)h(y)$ and we are integrating over the rectangle $R = [a, b] \times [c, d]$ then,

$$\iint_R f(x, y) dA = \iint_R g(x)h(y) dA = \left(\int_a^b g(x) dx \right) \left(\int_c^d h(y) dy \right)$$

So, if we can break up the function into a function only of x times a function of y then we can do the two integrals individually and multiply them together.

Let's do a quick example using this integral.

Example 2 Evaluate $\iint_R x \cos^2(y) dA$, $R = [-2, 3] \times \left[0, \frac{\pi}{2}\right]$.

Solution

Since the integrand is a function of x times a function of y we can use the fact.

$$\begin{aligned} \iint_R x \cos^2(y) dA &= \left(\int_{-2}^3 x dx \right) \left(\int_0^{\frac{\pi}{2}} \cos^2(y) dy \right) \\ &= \left(\frac{1}{2} x^2 \right) \Big|_{-2}^3 \left(\frac{1}{2} \int_0^{\frac{\pi}{2}} 1 + \cos(2y) dy \right) \\ &= \left(\frac{5}{2} \right) \left(\frac{1}{2} \left(y + \frac{1}{2} \sin(2y) \right) \Big|_0^{\frac{\pi}{2}} \right) \\ &= \frac{5\pi}{8} \end{aligned}$$

We have one more topic to discuss in this section. This topic really doesn't have anything to do with iterated integrals, but this is as good a place as any to put it and there are liable to be some questions about it at this point as well so this is as good a place as any.

What we want to do is discuss single indefinite integrals of a function of two variables. In other words we want to look at integrals like the following.

$$\int x \sec^2(2y) + 4xy dy$$

$$\int x^3 - e^{-\frac{x}{y}} dx$$

From Calculus I we know that these integrals are asking what function that we differentiated to get the integrand. However, in this case we need to pay attention to the differential (dy or dx) in the integral, because that will change things a little.

In the case of the first integral we are asking what function we differentiated with respect to y to get the integrand while in the second integral we're asking what function differentiated with

respect to x to get the integrand. For the most part answering these questions isn't that difficult. The important issue is how we deal with the constant of integration.

Here are the integrals.

$$\int x \sec^2(2y) + 4xy \, dy = \frac{x}{2} \tan(2y) + 2xy^2 + g(x)$$

$$\int x^3 - e^{-\frac{x}{y}} \, dx = \frac{1}{4}x^4 + y e^{-\frac{x}{y}} + h(y)$$

Notice that the “constants” of integration are now functions of the opposite variable. In the first integral we are differentiating with respect to y and we know that any function involving only x 's will differentiate to zero and so when integrating with respect to y we need to acknowledge that there may have been a function of only x 's in the function and so the “constant” of integration is a function of x .

Likewise, in the second integral, the “constant” of integration must be a function of y since we are integrating with respect to x . Again, remember if we differentiate the answer with respect to x then any function of only y 's will differentiate to zero.

Double Integrals Over General Regions

In the previous section we looked at double integrals over rectangular regions. The problem with this is that most of the regions are not rectangular so we need to now look at the following double integral,

$$\iint_D f(x, y) dA$$

where D is any region.

There are two types of regions that we need to look at. Here is a sketch of both of them.

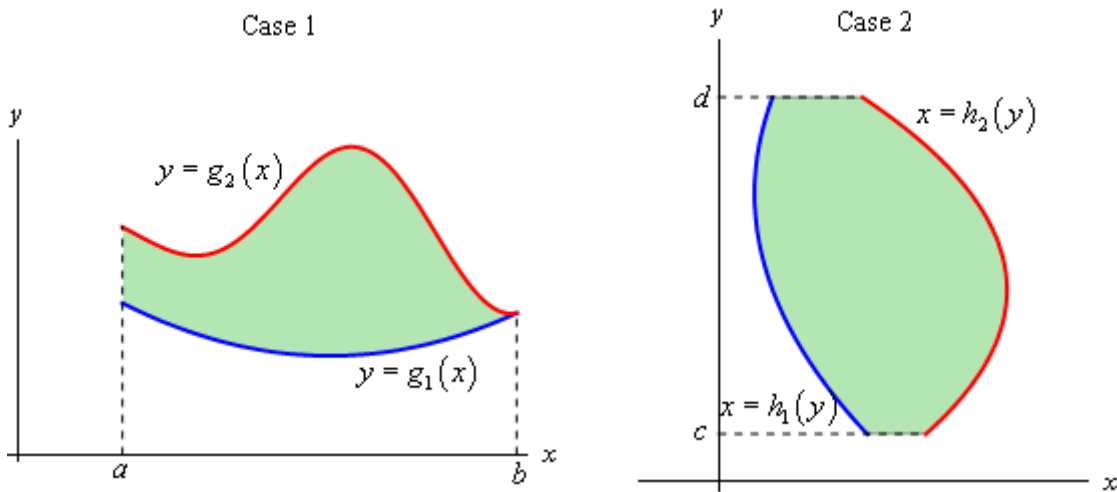

We will often use *set builder notation* to describe these regions. Here is the definition for the region in Case 1

$$D = \{(x, y) \mid a \leq x \leq b, g_1(x) \leq y \leq g_2(x)\}$$

and here is the definition for the region in Case 2.

$$D = \{(x, y) \mid h_1(y) \leq x \leq h_2(y), c \leq y \leq d\}$$

This notation is really just a fancy way of saying we are going to use all the points, (x, y) , in which both of the coordinates satisfy the two given inequalities.

The double integral for both of these cases are defined in terms of iterated integrals as follows.

In Case 1 where $D = \{(x, y) \mid a \leq x \leq b, g_1(x) \leq y \leq g_2(x)\}$ the integral is defined to be,

$$\iint_D f(x, y) dA = \int_a^b \int_{g_1(x)}^{g_2(x)} f(x, y) dy dx$$

In Case 2 where $D = \{(x, y) \mid h_1(y) \leq x \leq h_2(y), c \leq y \leq d\}$ the integral is defined to be,

$$\iint_D f(x, y) dA = \int_c^d \int_{h_1(y)}^{h_2(y)} f(x, y) dx dy$$

Here are some properties of the double integral that we should go over before we actually do some examples. Note that all three of these properties are really just extensions of properties of single integrals that have been extended to double integrals.

Properties

$$1. \iint_D f(x, y) + g(x, y) dA = \iint_D f(x, y) dA + \iint_D g(x, y) dA$$

$$2. \iint_D cf(x, y) dA = c \iint_D f(x, y) dA, \text{ where } c \text{ is any constant.}$$

3. If the region D can be split into two separate regions D_1 and D_2 then the integral can be written as

$$\iint_D f(x, y) dA = \iint_{D_1} f(x, y) dA + \iint_{D_2} f(x, y) dA$$

Let's take a look at some examples of double integrals over general regions.

Example 1 Evaluate each of the following integrals over the given region D .

$$(a) \iint_D e^{\frac{x}{y}} dA, \quad D = \{(x, y) \mid 1 \leq y \leq 2, y \leq x \leq y^3\} \quad [\text{Solution}]$$

$$(b) \iint_D 4xy - y^3 dA, \quad D \text{ is the region bounded by } y = \sqrt{x} \text{ and } y = x^3. \quad [\text{Solution}]$$

$$(c) \iint_D 6x^2 - 40y dA, \quad D \text{ is the triangle with vertices } (0, 3), (1, 1), \text{ and } (5, 3). \quad [\text{Solution}]$$

Solution

$$(a) \iint_D e^{\frac{x}{y}} dA, \quad D = \{(x, y) \mid 1 \leq y \leq 2, y \leq x \leq y^3\}$$

Okay, this first one is set up to just use the formula above so let's do that.

$$\begin{aligned} \iint_D e^{\frac{x}{y}} dA &= \int_1^2 \int_y^{y^3} e^{\frac{x}{y}} dx dy = \int_1^2 y e^{\frac{x}{y}} \Big|_y^{y^3} dy \\ &= \int_1^2 y e^{y^2} - y e^1 dy \\ &= \left(\frac{1}{2} e^{y^2} - \frac{1}{2} y^2 e^1 \right) \Big|_1^2 = \frac{1}{2} e^4 - 2e^1 \end{aligned}$$

[\[Return to Problems\]](#)

(b) $\iint_D 4xy - y^3 \, dA$, D is the region bounded by $y = \sqrt{x}$ and $y = x^3$.

In this case we need to determine the two inequalities for x and y that we need to do the integral. The best way to do this is the graph the two curves. Here is a sketch.

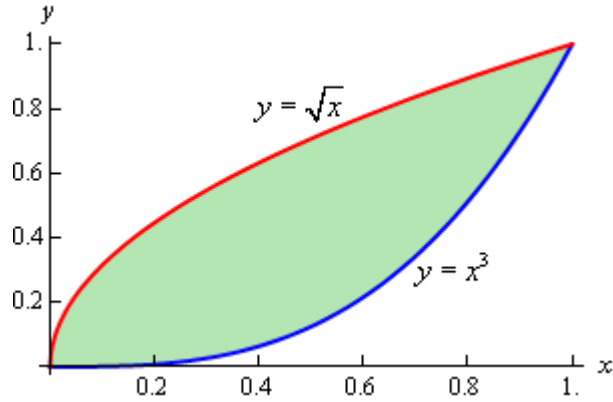

So, from the sketch we can see that that two inequalities are,

$$0 \leq x \leq 1 \quad x^3 \leq y \leq \sqrt{x}$$

We can now do the integral,

$$\begin{aligned} \iint_D 4xy - y^3 \, dA &= \int_0^1 \int_{x^3}^{\sqrt{x}} 4xy - y^3 \, dy \, dx \\ &= \int_0^1 \left(2xy^2 - \frac{1}{4}y^4 \right) \Big|_{x^3}^{\sqrt{x}} \, dx \\ &= \int_0^1 \frac{7}{4}x^2 - 2x^7 + \frac{1}{4}x^{12} \, dx \\ &= \left(\frac{7}{12}x^3 - \frac{1}{4}x^8 + \frac{1}{52}x^{13} \right) \Big|_0^1 = \frac{55}{156} \end{aligned}$$

[\[Return to Problems\]](#)

(c) $\iint_D 6x^2 - 40y \, dA$, D is the triangle with vertices $(0,3)$, $(1,1)$, and $(5,3)$.

We got even less information about the region this time. Let's start this off by sketching the triangle.

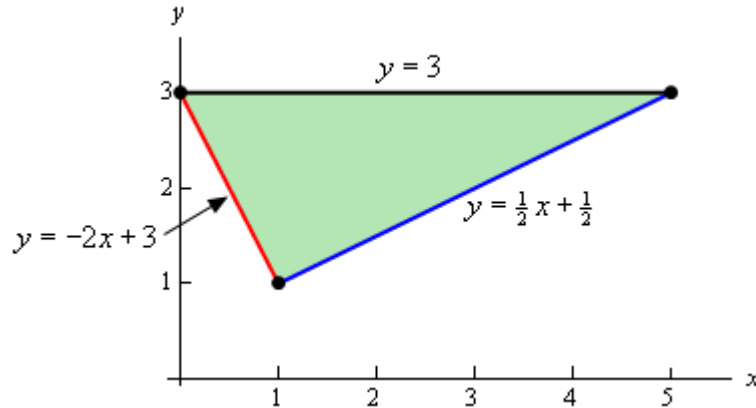

Since we have two points on each edge it is easy to get the equations for each edge and so we'll leave it to you to verify the equations.

Now, there are two ways to describe this region. If we use functions of x , as shown in the image we will have to break the region up into two different pieces since the lower function is different depending upon the value of x . In this case the region would be given by $D = D_1 \cup D_2$ where,

$$D_1 = \left\{ (x, y) \mid 0 \leq x \leq 1, -2x + 3 \leq y \leq 3 \right\}$$

$$D_2 = \left\{ (x, y) \mid 1 \leq x \leq 5, \frac{1}{2}x + \frac{1}{2} \leq y \leq 3 \right\}$$

Note the \cup is the "union" symbol and just means that D is the region we get by combining the two regions. If we do this then we'll need to do two separate integrals, one for each of the regions.

To avoid this we could turn things around and solve the two equations for x to get,

$$y = -2x + 3 \quad \Rightarrow \quad x = -\frac{1}{2}y + \frac{3}{2}$$

$$y = \frac{1}{2}x + \frac{1}{2} \quad \Rightarrow \quad x = 2y - 1$$

If we do this we can notice that the same function is always on the right and the same function is always on the left and so the region is,

$$D = \left\{ (x, y) \mid -\frac{1}{2}y + \frac{3}{2} \leq x \leq 2y - 1, 1 \leq y \leq 3 \right\}$$

Writing the region in this form means doing a single integral instead of the two integrals we'd have to do otherwise.

Either way should give the same answer and so we can get an example in the notes of splitting a region up let's do both integrals.

Solution 1

$$\begin{aligned}
\iint_D 6x^2 - 40y \, dA &= \iint_{D_1} 6x^2 - 40y \, dA + \iint_{D_2} 6x^2 - 40y \, dA \\
&= \int_0^1 \int_{-2x+3}^3 6x^2 - 40y \, dy \, dx + \int_1^5 \int_{\frac{1}{2}x+\frac{1}{2}}^3 6x^2 - 40y \, dy \, dx \\
&= \int_0^1 (6x^2y - 20y^2) \Big|_{-2x+3}^3 \, dx + \int_1^5 (6x^2y - 20y^2) \Big|_{\frac{1}{2}x+\frac{1}{2}}^3 \, dx \\
&= \int_0^1 12x^3 - 180 + 20(3-2x)^2 \, dx + \int_1^5 -3x^3 + 15x^2 - 180 + 20\left(\frac{1}{2}x + \frac{1}{2}\right)^2 \, dx \\
&= \left(3x^4 - 180x - \frac{10}{3}(3-2x)^3\right) \Big|_0^1 + \left(-\frac{3}{4}x^4 + 5x^3 - 180x + \frac{40}{3}\left(\frac{1}{2}x + \frac{1}{2}\right)^3\right) \Big|_1^5 \\
&= -\frac{935}{3}
\end{aligned}$$

That was a lot of work. Notice however, that after we did the first substitution that we didn't multiply everything out. The two quadratic terms can be easily integrated with a basic Calc I substitution and so we didn't bother to multiply them out. We'll do that on occasion to make some of these integrals a little easier.

Solution 2

This solution will be a lot less work since we are only going to do a single integral.

$$\begin{aligned}
\iint_D 6x^2 - 40y \, dA &= \int_1^3 \int_{-\frac{1}{2}y+\frac{3}{2}}^{2y-1} 6x^2 - 40y \, dx \, dy \\
&= \int_1^3 (2x^3 - 40xy) \Big|_{-\frac{1}{2}y+\frac{3}{2}}^{2y-1} \, dy \\
&= \int_1^3 100y - 100y^2 + 2(2y-1)^3 - 2\left(-\frac{1}{2}y + \frac{3}{2}\right)^3 \, dy \\
&= \left(50y^2 - \frac{100}{3}y^3 + \frac{1}{4}(2y-1)^4 + \left(-\frac{1}{2}y + \frac{3}{2}\right)^4\right) \Big|_1^3 \\
&= -\frac{935}{3}
\end{aligned}$$

So, the numbers were a little messier, but other than that there was much less work for the same result. Also notice that again we didn't cube out the two terms as they are easier to deal with using a Calc I substitution.

[\[Return to Problems\]](#)

As the last part of the previous example has shown us we can integrate these integrals in either order (*i.e.* x followed by y or y followed by x), although often one order will be easier than the other. In fact there will be times when it will not even be possible to do the integral in one order while it will be possible to do the integral in the other order.

Let's see a couple of examples of these kinds of integrals.

Example 2 Evaluate the following integrals by first reversing the order of integration.

(a) $\int_0^3 \int_{x^2}^9 x^3 e^{y^3} dy dx$ [Solution]

(b) $\int_0^8 \int_{\sqrt[3]{y}}^2 \sqrt{x^4 + 1} dx dy$ [Solution]

Solution

(a) $\int_0^3 \int_{x^2}^9 x^3 e^{y^3} dy dx$

First, notice that if we try to integrate with respect to y we can't do the integral because we would need a y^2 in front of the exponential in order to do the y integration. We are going to hope that if we reverse the order of integration we will get an integral that we can do.

Now, when we say that we're going to reverse the order of integration this means that we want to integrate with respect to x first and then y . Note as well that we can't just interchange the integrals, keeping the original limits, and be done with it. This would not fix our original problem and in order to integrate with respect to x we can't have x 's in the limits of the integrals. Even if we ignored that the answer would not be a constant as it should be.

So, let's see how we reverse the order of integration. The best way to reverse the order of integration is to first sketch the region given by the original limits of integration. From the integral we see that the inequalities that define this region are,

$$0 \leq x \leq 3$$

$$x^2 \leq y \leq 9$$

These inequalities tell us that we want the region with $y = x^2$ on the lower boundary and $y = 9$ on the upper boundary that lies between $x = 0$ and $x = 3$. Here is a sketch of that region.

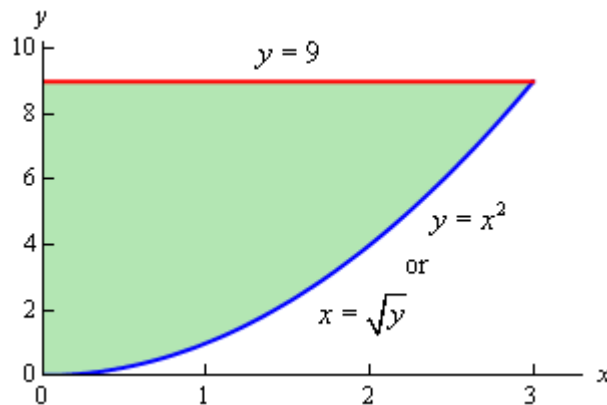

Since we want to integrate with respect to x first we will need to determine limits of x (probably in terms of y) and then get the limits on the y 's. Here they are for this region.

$$0 \leq x \leq \sqrt{y}$$

$$0 \leq y \leq 9$$

Any horizontal line drawn in this region will start at $x = 0$ and end at $x = \sqrt{y}$ and so these are the limits on the x 's and the range of y 's for the regions is 0 to 9.

The integral, with the order reversed, is now,

$$\int_0^3 \int_{x^2}^9 x^3 e^{y^3} dy dx = \int_0^9 \int_0^{\sqrt{y}} x^3 e^{y^3} dx dy$$

and notice that we can do the first integration with this order. We'll also hope that this will give us a second integral that we can do. Here is the work for this integral.

$$\begin{aligned} \int_0^3 \int_{x^2}^9 x^3 e^{y^3} dy dx &= \int_0^9 \int_0^{\sqrt{y}} x^3 e^{y^3} dx dy \\ &= \int_0^9 \left. \frac{1}{4} x^4 e^{y^3} \right|_0^{\sqrt{y}} dy \\ &= \int_0^9 \frac{1}{4} y^2 e^{y^3} dy \\ &= \left. \frac{1}{12} e^{y^3} \right|_0^9 \\ &= \frac{1}{12} (e^{729} - 1) \end{aligned}$$

[\[Return to Problems\]](#)

(b) $\int_0^8 \int_{\sqrt[3]{y}}^2 \sqrt{x^4 + 1} dx dy$

As with the first integral we cannot do this integral by integrating with respect to x first so we'll hope that by reversing the order of integration we will get something that we can integrate. Here are the limits for the variables that we get from this integral.

$$\begin{aligned} \sqrt[3]{y} &\leq x \leq 2 \\ 0 &\leq y \leq 8 \end{aligned}$$

and here is a sketch of this region.

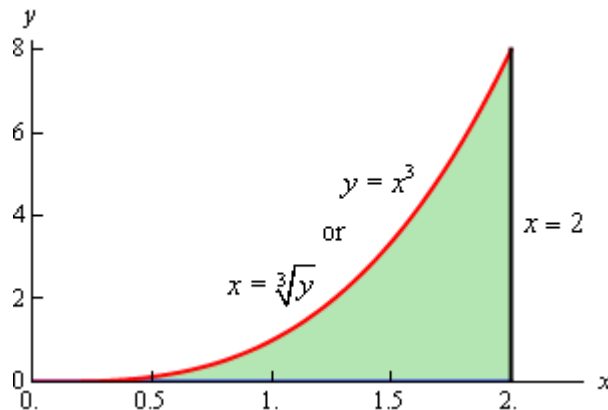

So, if we reverse the order of integration we get the following limits.

$$0 \leq x \leq 2$$

$$0 \leq y \leq x^3$$

The integral is then,

$$\begin{aligned} \int_0^8 \int_{\sqrt[3]{y}}^2 \sqrt{x^4+1} \, dx \, dy &= \int_0^2 \int_0^{x^3} \sqrt{x^4+1} \, dy \, dx \\ &= \int_0^2 y \sqrt{x^4+1} \Big|_0^{x^3} \, dx \\ &= \int_0^2 x^3 \sqrt{x^4+1} \, dx = \frac{1}{6} \left(17^{\frac{3}{2}} - 1 \right) \end{aligned}$$

[\[Return to Problems\]](#)

The final topic of this section is two geometric interpretations of a double integral. The first interpretation is an extension of the idea that we used to develop the idea of a double integral in the first [section](#) of this chapter. We did this by looking at the volume of the solid that was below the surface of the function $z = f(x, y)$ and over the rectangle R in the xy -plane. This idea can be extended to more general regions.

The volume of the solid that lies below the surface given by $z = f(x, y)$ and above the region D in the xy -plane is given by,

$$V = \iint_D f(x, y) \, dA$$

Example 3 Find the volume of the solid that lies below the surface given by $z = 16xy + 200$ and lies above the region in the xy -plane bounded by $y = x^2$ and $y = 8 - x^2$.

Solution

Here is the graph of the surface and we've tried to show the region in the xy -plane below the surface.

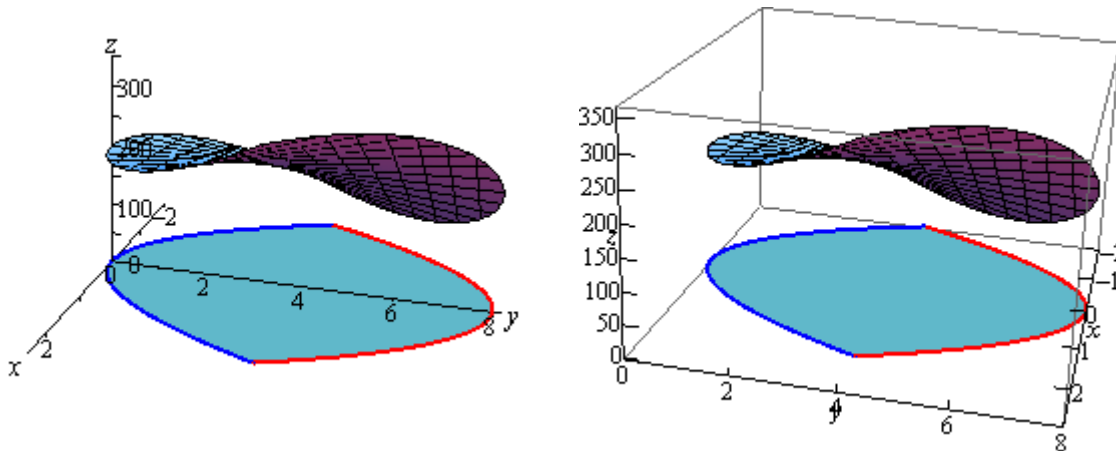

Here is a sketch of the region in the xy -plane by itself.

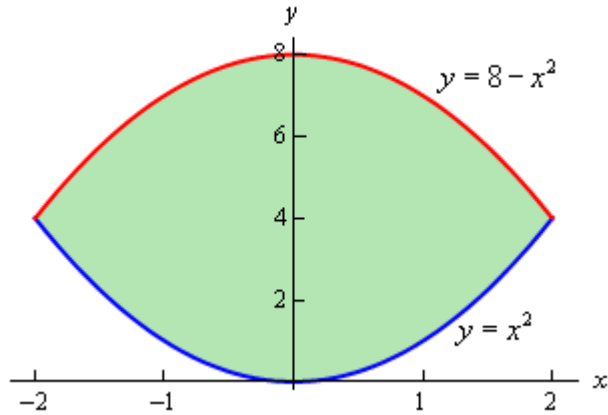

By setting the two bounding equations equal we can see that they will intersect at $x = 2$ and $x = -2$. So, the inequalities that will define the region D in the xy -plane are,

$$\begin{aligned} -2 \leq x \leq 2 \\ x^2 \leq y \leq 8 - x^2 \end{aligned}$$

The volume is then given by,

$$\begin{aligned} V &= \iint_D 16xy + 200 \, dA \\ &= \int_{-2}^2 \int_{x^2}^{8-x^2} 16xy + 200 \, dy \, dx \\ &= \int_{-2}^2 (8xy^2 + 200y) \Big|_{x^2}^{8-x^2} \, dx \\ &= \int_{-2}^2 -128x^3 - 400x^2 + 512x + 1600 \, dx \\ &= \left(-32x^4 - \frac{400}{3}x^3 + 256x^2 + 1600x \right) \Big|_{-2}^2 = \frac{12800}{3} \end{aligned}$$

Example 4 Find the volume of the solid enclosed by the planes $4x + 2y + z = 10$, $y = 3x$, $z = 0$, $x = 0$.

Solution This example is a little different from the previous one. Here the region D is not explicitly given so we're going to have to find it. First, notice that the last two planes are really telling us that we won't go past the xy -plane and the yz -plane when we reach them.

The first plane, $4x + 2y + z = 10$, is the top of the volume and so we are really looking for the volume under,

$$z = 10 - 4x - 2y$$

and above the region D in the xy -plane. The second plane, $y = 3x$ (yes that is a plane), gives one of the sides of the volume as shown below.

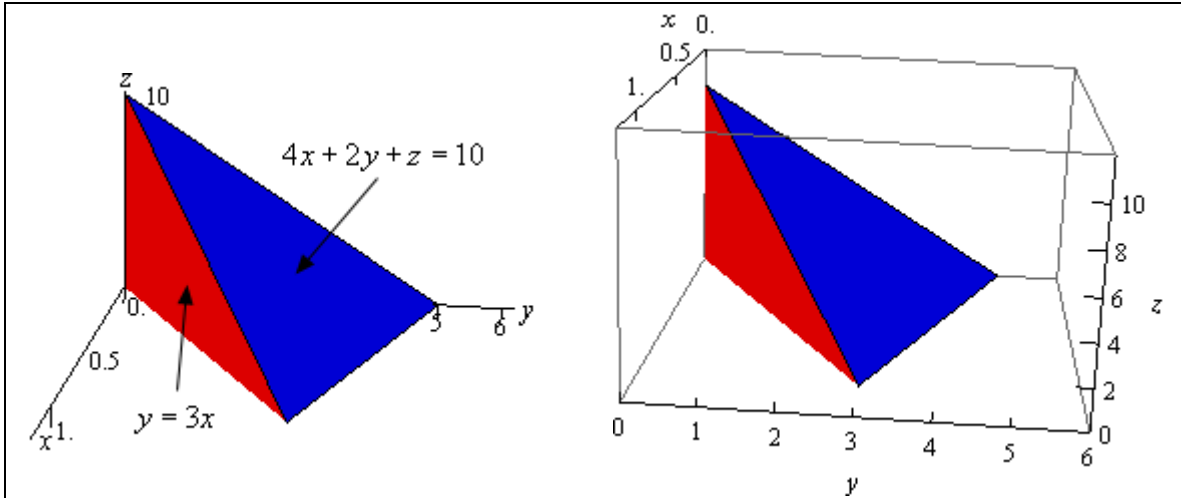

The region D will be the region in the xy -plane (*i.e.* $z = 0$) that is bounded by $y = 3x$, $x = 0$, and the line where $z + 4x + 2y = 10$ intersects the xy -plane. We can determine where $z + 4x + 2y = 10$ intersects the xy -plane by plugging $z = 0$ into it.

$$0 + 4x + 2y = 10 \quad \Rightarrow \quad 2x + y = 5 \quad \Rightarrow \quad y = -2x + 5$$

So, here is a sketch the region D .

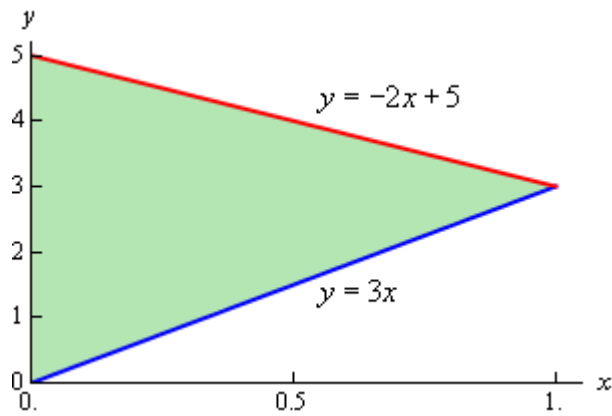

The region D is really where this solid will sit on the xy -plane and here are the inequalities that define the region.

$$0 \leq x \leq 1$$

$$3x \leq y \leq -2x + 5$$

Here is the volume of this solid.

$$\begin{aligned}
 V &= \iint_D 10 - 4x - 2y \, dA \\
 &= \int_0^1 \int_{3x}^{-2x+5} 10 - 4x - 2y \, dy \, dx \\
 &= \int_0^1 (10y - 4xy - y^2) \Big|_{3x}^{-2x+5} \, dx \\
 &= \int_0^1 25x^2 - 50x + 25 \, dx \\
 &= \left(\frac{25}{3}x^3 - 25x^2 + 25x \right) \Big|_0^1 = \frac{25}{3}
 \end{aligned}$$

The second geometric interpretation of a double integral is the following.

$$\text{Area of } D = \iint_D dA$$

This is easy to see why this is true in general. Let's suppose that we want to find the area of the region shown below.

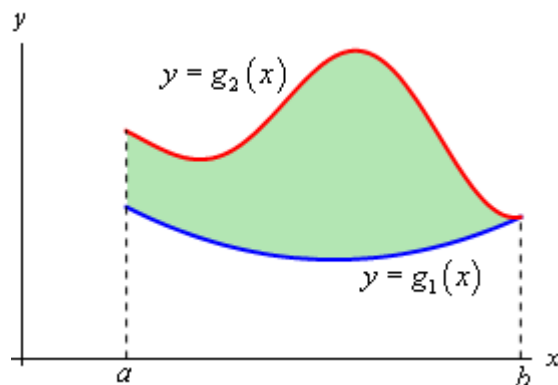

From Calculus I we know that this area can be found by the integral,

$$A = \int_a^b g_2(x) - g_1(x) \, dx$$

Or in terms of a double integral we have,

$$\begin{aligned}
 \text{Area of } D &= \iint_D dA \\
 &= \int_a^b \int_{g_1(x)}^{g_2(x)} dy \, dx \\
 &= \int_a^b y \Big|_{g_1(x)}^{g_2(x)} \, dx = \int_a^b g_2(x) - g_1(x) \, dx
 \end{aligned}$$

This is exactly the same formula we had in Calculus I.

Double Integrals in Polar Coordinates

To this point we've seen quite a few double integrals. However, in every case we've seen to this point the region D could be easily described in terms of simple functions in Cartesian coordinates. In this section we want to look at some regions that are much easier to describe in terms of polar coordinates. For instance, we might have a region that is a disk, ring, or a portion of a disk or ring. In these cases using Cartesian coordinates could be somewhat cumbersome. For instance let's suppose we wanted to do the following integral,

$$\iint_D f(x, y) dA, \quad D \text{ is the disk of radius } 2$$

To this we would have to determine a set of inequalities for x and y that describe this region. These would be,

$$\begin{aligned} -2 &\leq x \leq 2 \\ -\sqrt{4-x^2} &\leq y \leq \sqrt{4-x^2} \end{aligned}$$

With these limits the integral would become,

$$\iint_D f(x, y) dA = \int_{-2}^2 \int_{-\sqrt{4-x^2}}^{\sqrt{4-x^2}} f(x, y) dy dx$$

Due to the limits on the inner integral this is liable to be an unpleasant integral to compute.

However, a disk of radius 2 can be defined in polar coordinates by the following inequalities,

$$\begin{aligned} 0 &\leq \theta \leq 2\pi \\ 0 &\leq r \leq 2 \end{aligned}$$

These are very simple limits and, in fact, are constant limits of integration which almost always makes integrals somewhat easier.

So, if we could convert our double integral formula into one involving polar coordinates we would be in pretty good shape. The problem is that we can't just convert the dx and the dy into a dr and a $d\theta$. In computing double integrals to this point we have been using the fact that $dA = dx dy$ and this really does require Cartesian coordinates to use. Once we've moved into polar coordinates $dA \neq dr d\theta$ and so we're going to need to determine just what dA is under polar coordinates.

So, let's step back a little bit and start off with a general region in terms of polar coordinates and see what we can do with that. Here is a sketch of some region using polar coordinates.

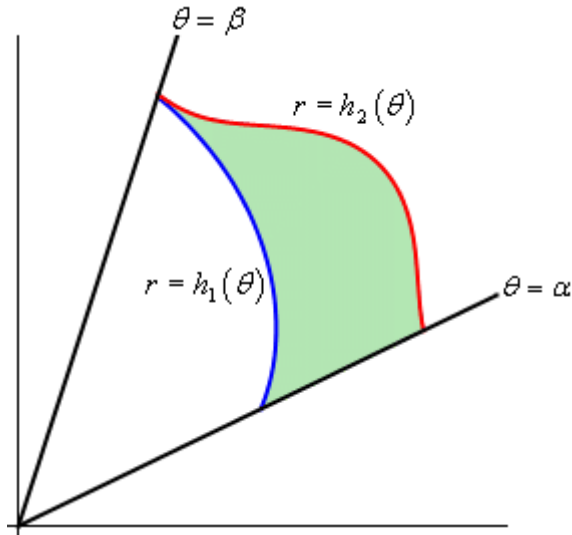

So, our general region will be defined by inequalities,

$$\alpha \leq \theta \leq \beta$$

$$h_1(\theta) \leq r \leq h_2(\theta)$$

Now, to find dA let's redo the figure above as follows,

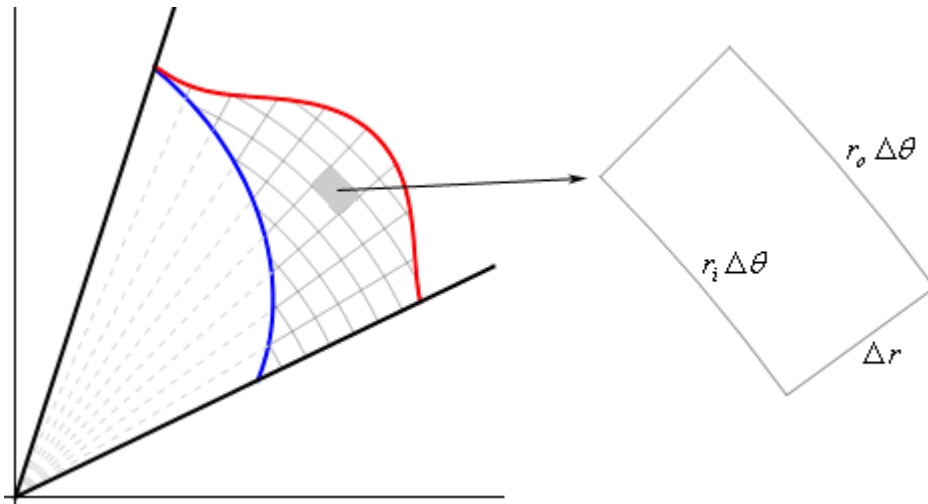

As shown, we'll break up the region into a mesh of radial lines and arcs. Now, if we pull one of the pieces of the mesh out as shown we have something that is almost, but not quite a rectangle. The area of this piece is ΔA . The two sides of this piece both have length $\Delta r = r_o - r_i$ where r_o is the radius of the outer arc and r_i is the radius of the inner arc. Basic geometry then tells us that the length of the inner edge is $r_i \Delta \theta$ while the length of the out edge is $r_o \Delta \theta$ where $\Delta \theta$ is the angle between the two radial lines that form the sides of this piece.

Now, let's assume that we've taken the mesh so small that we can assume that $r_i \approx r_o = r$ and with this assumption we can also assume that our piece is close enough to a rectangle that we can also then assume that,

$$\Delta A \approx r \Delta \theta \Delta r$$

Also, if we assume that the mesh is small enough then we can also assume that,

$$dA \approx \Delta A \qquad d\theta \approx \Delta \theta \qquad dr \approx \Delta r$$

With these assumptions we then get $dA \approx r dr d\theta$.

In order to arrive at this we had to make the assumption that the mesh was very small. This is not an unreasonable assumption. [Recall](#) that the definition of a double integral is in terms of two limits and as limits go to infinity the mesh size of the region will get smaller and smaller. In fact, as the mesh size gets smaller and smaller the formula above becomes more and more accurate and so we can say that,

$$dA = r dr d\theta$$

We'll see another way of deriving this once we reach the [Change of Variables](#) section later in this chapter. This second way will not involve any assumptions either and so it maybe a little better way of deriving this.

Before moving on it is again important to note that $dA \neq dr d\theta$. The actual formula for dA has an r in it. It will be easy to forget this r on occasion, but as you'll see without it some integrals will not be possible to do.

Now, if we're going to be converting an integral in Cartesian coordinates into an integral in polar coordinates we are going to have to make sure that we've also converted all the x 's and y 's into polar coordinates as well. To do this we'll need to remember the following conversion formulas,

$$x = r \cos \theta \qquad y = r \sin \theta \qquad r^2 = x^2 + y^2$$

We are now ready to write down a formula for the double integral in terms of polar coordinates.

$$\iint_D f(x, y) dA = \int_{\alpha}^{\beta} \int_{h_1(\theta)}^{h_2(\theta)} f(r \cos \theta, r \sin \theta) r dr d\theta$$

It is important to not forget the added r and don't forget to convert the Cartesian coordinates in the function over to polar coordinates.

Let's look at a couple of examples of these kinds of integrals.

Example 1 Evaluate the following integrals by converting them into polar coordinates.

(a) $\iint_D 2xy \, dA$, D is the portion of the region between the circles of radius 2 and radius 5 centered at the origin that lies in the first quadrant. [\[Solution\]](#)

(b) $\iint_D e^{x^2+y^2} \, dA$, D is the unit circle centered at the origin. [\[Solution\]](#)

Solution

(a) $\iint_D 2xy \, dA$, D is the portion of the region between the circles of radius 2 and radius 5 centered at the origin that lies in the first quadrant.

First let's get D in terms of polar coordinates. The circle of radius 2 is given by $r = 2$ and the circle of radius 5 is given by $r = 5$. We want the region between them so we will have the following inequality for r .

$$2 \leq r \leq 5$$

Also, since we only want the portion that is in the first quadrant we get the following range of θ 's.

$$0 \leq \theta \leq \frac{\pi}{2}$$

Now that we've got these we can do the integral.

$$\iint_D 2xy \, dA = \int_0^{\frac{\pi}{2}} \int_2^5 2(r \cos \theta)(r \sin \theta) r \, dr \, d\theta$$

Don't forget to do the conversions and to add in the extra r . Now, let's simplify and make use of the double angle formula for sine to make the integral a little easier.

$$\begin{aligned} \iint_D 2xy \, dA &= \int_0^{\frac{\pi}{2}} \int_2^5 r^3 \sin(2\theta) \, dr \, d\theta \\ &= \int_0^{\frac{\pi}{2}} \left. \frac{1}{4} r^4 \sin(2\theta) \right|_2^5 \, d\theta \\ &= \int_0^{\frac{\pi}{2}} \frac{609}{4} \sin(2\theta) \, d\theta \\ &= -\frac{609}{8} \cos(2\theta) \Big|_0^{\frac{\pi}{2}} \\ &= \frac{609}{4} \end{aligned}$$

[\[Return to Problems\]](#)

(b) $\iint_D e^{x^2+y^2} dA$, D is the unit circle centered at the origin.

In this case we can't do this integral in terms of Cartesian coordinates. We will however be able to do it in polar coordinates. First, the region D is defined by,

$$\begin{aligned} 0 \leq \theta \leq 2\pi \\ 0 \leq r \leq 1 \end{aligned}$$

In terms of polar coordinates the integral is then,

$$\iint_D e^{x^2+y^2} dA = \int_0^{2\pi} \int_0^1 r e^{r^2} dr d\theta$$

Notice that the addition of the r gives us an integral that we can now do. Here is the work for this integral.

$$\begin{aligned} \iint_D e^{x^2+y^2} dA &= \int_0^{2\pi} \int_0^1 r e^{r^2} dr d\theta \\ &= \int_0^{2\pi} \left. \frac{1}{2} e^{r^2} \right|_0^1 d\theta \\ &= \int_0^{2\pi} \frac{1}{2} (e-1) d\theta \\ &= \pi (e-1) \end{aligned}$$

[\[Return to Problems\]](#)

Let's not forget that we still have the two geometric interpretations for these integrals as well.

Example 2 Determine the area of the region that lies inside $r = 3 + 2 \sin \theta$ and outside $r = 2$.

Solution

Here is a sketch of the region, D , that we want to determine the area of.

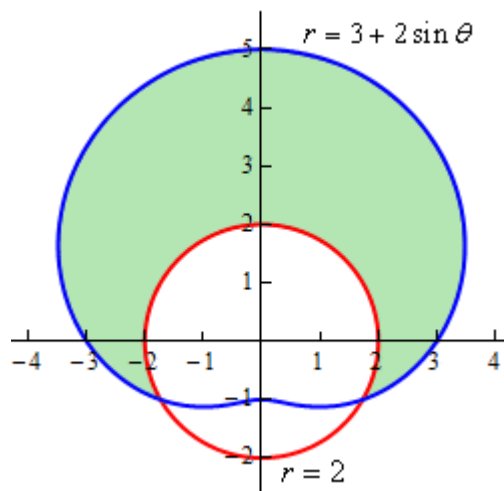

To determine this area we'll need to know that value of θ for which the two curves intersect. We can determine these points by setting the two equations and solving.

$$3 + 2 \sin \theta = 2$$

$$\sin \theta = -\frac{1}{2} \quad \Rightarrow \quad \theta = \frac{7\pi}{6}, \frac{11\pi}{6}$$

Here is a sketch of the figure with these angles added.

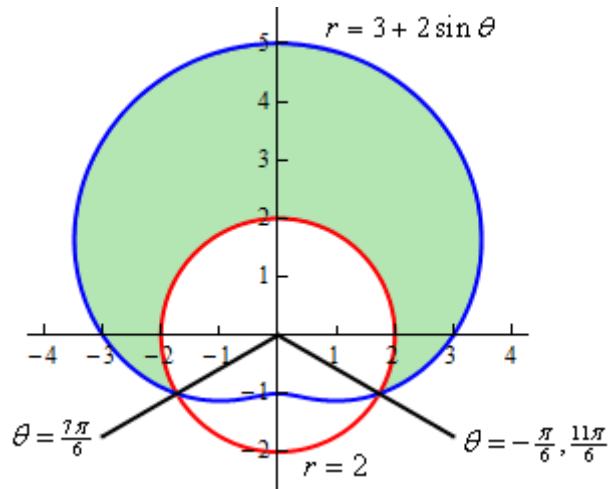

Note as well that we've acknowledged that $-\frac{\pi}{6}$ is another representation for the angle $\frac{11\pi}{6}$. This is important since we need the range of θ to actually enclose the regions as we increase from the lower limit to the upper limit. If we'd chosen to use $\frac{11\pi}{6}$ then as we increase from $\frac{7\pi}{6}$ to $\frac{11\pi}{6}$ we would be tracing out the lower portion of the circle and that is not the region that we are after.

So, here are the ranges that will define the region.

$$-\frac{\pi}{6} \leq \theta \leq \frac{7\pi}{6}$$

$$2 \leq r \leq 3 + 2 \sin \theta$$

To get the ranges for r the function that is closest to the origin is the lower bound and the function that is farthest from the origin is the upper bound.

The area of the region D is then,

$$\begin{aligned}
A &= \iint_D dA \\
&= \int_{-\pi/6}^{7\pi/6} \int_2^{3+2\sin\theta} r \, dr \, d\theta \\
&= \int_{-\pi/6}^{7\pi/6} \left. \frac{1}{2} r^2 \right|_2^{3+2\sin\theta} d\theta \\
&= \int_{-\pi/6}^{7\pi/6} \frac{5}{2} + 6\sin\theta + 2\sin^2\theta \, d\theta \\
&= \int_{-\pi/6}^{7\pi/6} \frac{7}{2} + 6\sin\theta - \cos(2\theta) \, d\theta \\
&= \left(\frac{7}{2}\theta - 6\cos\theta - \frac{1}{2}\sin(2\theta) \right) \Big|_{-\pi/6}^{7\pi/6} \\
&= \frac{11\sqrt{3}}{2} + \frac{14\pi}{3} = 24.187
\end{aligned}$$

Example 3 Determine the volume of the region that lies under the sphere $x^2 + y^2 + z^2 = 9$, above the plane $z = 0$ and inside the cylinder $x^2 + y^2 = 5$.

Solution

We know that the formula for finding the volume of a region is,

$$V = \iint_D f(x, y) \, dA$$

In order to make use of this formula we're going to need to determine the function that we should be integrating and the region D that we're going to be integrating over.

The function isn't too bad. It's just the sphere, however, we do need it to be in the form $z = f(x, y)$. We are looking at the region that lies under the sphere and above the plane $z = 0$ (just the xy -plane right?) and so all we need to do is solve the equation for z and when taking the square root we'll take the positive one since we are wanting the region above the xy -plane. Here is the function.

$$z = \sqrt{9 - x^2 - y^2}$$

The region D isn't too bad in this case either. As we take points, (x, y) , from the region we need to completely graph the portion of the sphere that we are working with. Since we only want the portion of the sphere that actually lies inside the cylinder given by $x^2 + y^2 = 5$ this is also the region D . The region D is the disk $x^2 + y^2 \leq 5$ in the xy -plane.

For reference purposes here is a sketch of the region that we are trying to find the volume of.

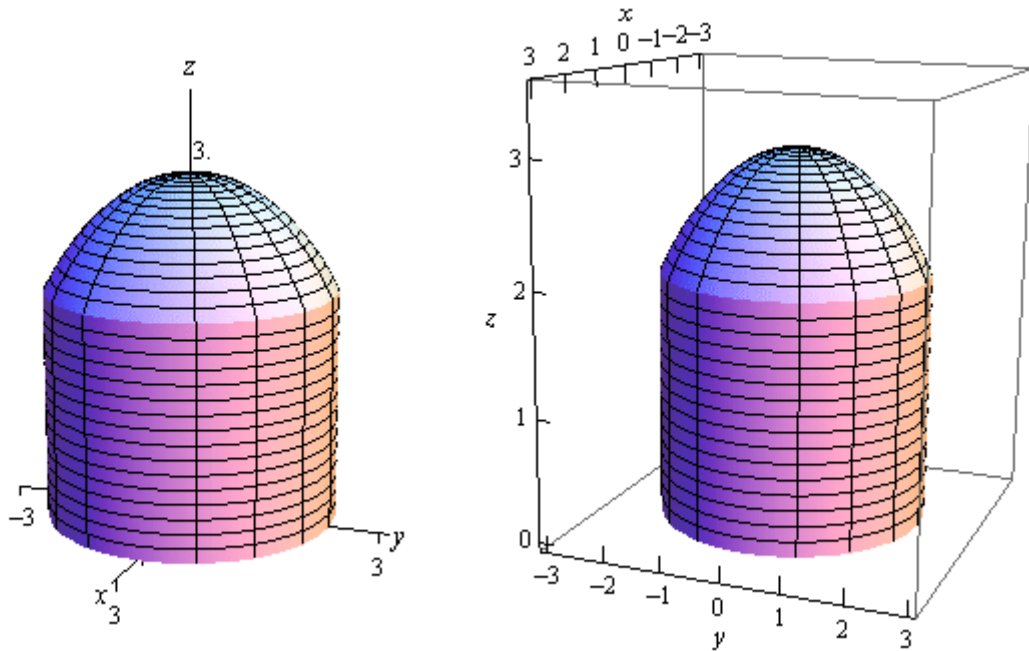

So, the region that we want the volume for is really a cylinder with a cap that comes from the sphere.

We are definitely going to want to do this integral in terms of polar coordinates so here are the limits (in polar coordinates) for the region,

$$0 \leq \theta \leq 2\pi$$

$$0 \leq r \leq \sqrt{5}$$

and we'll need to convert the function to polar coordinates as well.

$$z = \sqrt{9 - (x^2 + y^2)} = \sqrt{9 - r^2}$$

The volume is then,

$$\begin{aligned} V &= \iint_D \sqrt{9 - x^2 - y^2} \, dA \\ &= \int_0^{2\pi} \int_0^{\sqrt{5}} r \sqrt{9 - r^2} \, dr \, d\theta \\ &= \int_0^{2\pi} \left. -\frac{1}{3} (9 - r^2)^{\frac{3}{2}} \right|_0^{\sqrt{5}} d\theta \\ &= \int_0^{2\pi} \frac{19}{3} d\theta \\ &= \frac{38\pi}{3} \end{aligned}$$

Example 4 Find the volume of the region that lies inside $z = x^2 + y^2$ and below the plane $z = 16$.

Solution

Let's start this example off with a quick sketch of the region.

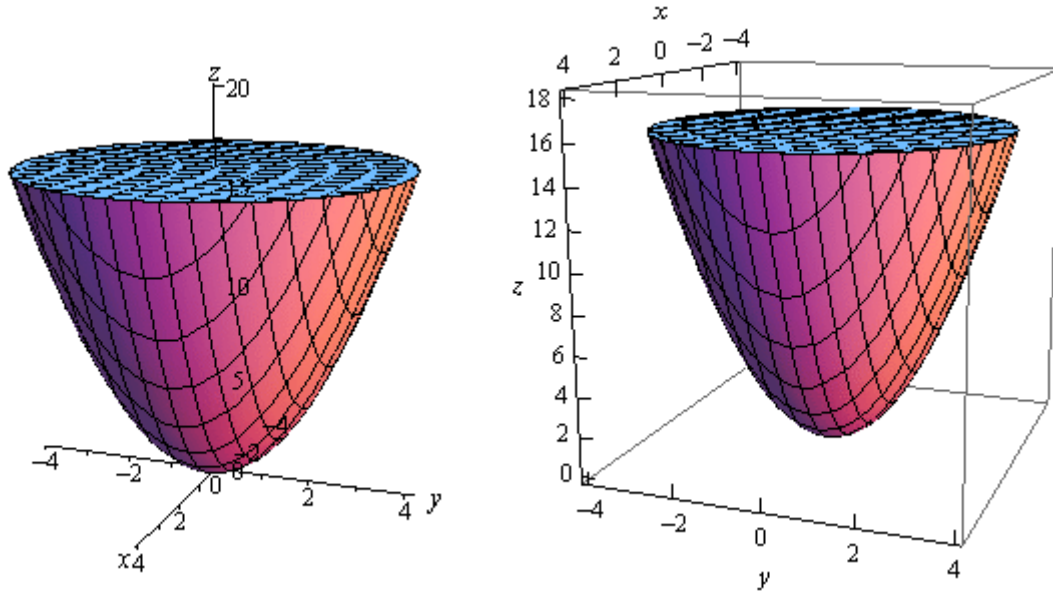

Now, in this case the standard formula is not going to work. The formula

$$V = \iint_D f(x, y) dA$$

finds the volume under the function $f(x, y)$ and we're actually after the area that is above a function. This isn't the problem that it might appear to be however. First, notice that

$$V = \iint_D 16 dA$$

will be the volume under $z = 16$ (of course we'll need to determine D eventually) while

$$V = \iint_D x^2 + y^2 dA$$

is the volume under $z = x^2 + y^2$, using the same D .

The volume that we're after is really the difference between these two or,

$$V = \iint_D 16 dA - \iint_D x^2 + y^2 dA = \iint_D 16 - (x^2 + y^2) dA$$

Now all that we need to do is to determine the region D and then convert everything over to polar coordinates.

Determining the region D in this case is not too bad. If we were to look straight down the z -axis onto the region we would see a circle of radius 4 centered at the origin. This is because the top of the region, where the elliptic paraboloid intersects the plane, is the widest part of the region. We know the z coordinate at the intersection so, setting $z = 16$ in the equation of the paraboloid gives,

$$16 = x^2 + y^2$$

which is the equation of a circle of radius 4 centered at the origin.

Here are the inequalities for the region and the function we'll be integrating in terms of polar coordinates.

$$0 \leq \theta \leq 2\pi \qquad 0 \leq r \leq 4 \qquad z = 16 - r^2$$

The volume is then,

$$\begin{aligned} V &= \iint_D 16 - (x^2 + y^2) dA \\ &= \int_0^{2\pi} \int_0^4 r(16 - r^2) dr d\theta \\ &= \int_0^{2\pi} \left(8r^2 - \frac{1}{4}r^4 \right) \Big|_0^4 d\theta \\ &= \int_0^{2\pi} 64 d\theta \\ &= 128\pi \end{aligned}$$

In both of the previous volume problems we would have not been able to easily compute the volume without first converting to polar coordinates so, as these examples show, it is a good idea to always remember polar coordinates.

There is one more type of example that we need to look at before moving on to the next section. Sometimes we are given an iterated integral that is already in terms of x and y and we need to convert this over to polar so that we can actually do the integral. We need to see an example of how to do this kind of conversion.

Example 5 Evaluate the following integral by first converting to polar coordinates.

$$\int_0^1 \int_0^{\sqrt{1-y^2}} \cos(x^2 + y^2) dx dy$$

Solution

First, notice that we cannot do this integral in Cartesian coordinates and so converting to polar coordinates may be the only option we have for actually doing the integral. Notice that the function will convert to polar coordinates nicely and so shouldn't be a problem.

Let's first determine the region that we're integrating over and see if it's a region that can be easily converted into polar coordinates. Here are the inequalities that define the region in terms of Cartesian coordinates.

$$\begin{aligned} 0 &\leq y \leq 1 \\ 0 &\leq x \leq \sqrt{1-y^2} \end{aligned}$$

Now, the upper limit for the x 's is,

$$x = \sqrt{1-y^2}$$

and this looks like the right side of the circle of radius 1 centered at the origin. Since the lower limit for the x 's is $x = 0$ it looks like we are going to have a portion (or all) of the right side of the disk of radius 1 centered at the origin.

The range for the y 's however, tells us that we are only going to have positive y 's. This means that we are only going to have the portion of the disk of radius 1 centered at the origin that is in the first quadrant.

So, we know that the inequalities that will define this region in terms of polar coordinates are then,

$$0 \leq \theta \leq \frac{\pi}{2}$$

$$0 \leq r \leq 1$$

Finally, we just need to remember that,

$$dx dy = dA = r dr d\theta$$

and so the integral becomes,

$$\int_0^1 \int_0^{\sqrt{1-y^2}} \cos(x^2 + y^2) dx dy = \int_0^{\frac{\pi}{2}} \int_0^1 r \cos(r^2) dr d\theta$$

Note that this is an integral that we can do. So, here is the rest of the work for this integral.

$$\begin{aligned} \int_0^1 \int_0^{\sqrt{1-y^2}} \cos(x^2 + y^2) dx dy &= \int_0^{\frac{\pi}{2}} \frac{1}{2} \sin(r^2) \Big|_0^1 d\theta \\ &= \int_0^{\frac{\pi}{2}} \frac{1}{2} \sin(1) d\theta \\ &= \frac{\pi}{4} \sin(1) \end{aligned}$$

Triple Integrals

Now that we know how to integrate over a two-dimensional region we need to move on to integrating over a three-dimensional region. We used a double integral to integrate over a two-dimensional region and so it shouldn't be too surprising that we'll use a **triple integral** to integrate over a three dimensional region. The notation for the general triple integrals is,

$$\iiint_E f(x, y, z) dV$$

Let's start simple by integrating over the box,

$$B = [a, b] \times [c, d] \times [r, s]$$

Note that when using this notation we list the x 's first, the y 's second and the z 's third.

The triple integral in this case is,

$$\iiint_B f(x, y, z) dV = \int_r^s \int_c^d \int_a^b f(x, y, z) dx dy dz$$

Note that we integrated with respect to x first, then y , and finally z here, but in fact there is no reason to the integrals in this order. There are 6 different possible orders to do the integral in and which order you do the integral in will depend upon the function and the order that you feel will be the easiest. We will get the same answer regardless of the order however.

Let's do a quick example of this type of triple integral.

Example 1 Evaluate the following integral.

$$\iiint_B 8xyz dV, \quad B = [2, 3] \times [1, 2] \times [0, 1]$$

Solution

Just to make the point that order doesn't matter let's use a different order from that listed above. We'll do the integral in the following order.

$$\begin{aligned} \iiint_B 8xyz dV &= \int_1^2 \int_2^3 \int_0^1 8xyz dz dx dy \\ &= \int_1^2 \int_2^3 4xyz^2 \Big|_0^1 dx dy \\ &= \int_1^2 \int_2^3 4xy dx dy \\ &= \int_1^2 2x^2 y \Big|_2^3 dy \\ &= \int_1^2 10y dy = 15 \end{aligned}$$

Before moving on to more general regions let's get a nice geometric interpretation about the triple integral out of the way so we can use it in some of the examples to follow.

Fact

The volume of the three-dimensional region E is given by the integral,

$$V = \iiint_E dV$$

Let's now move on the more general three-dimensional regions. We have three different possibilities for a general region. Here is a sketch of the first possibility.

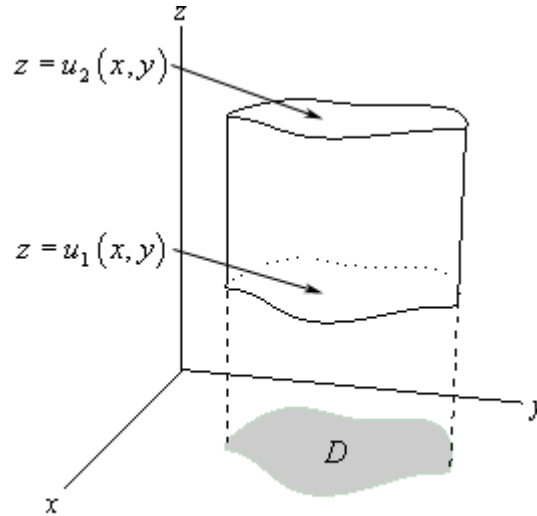

In this case we define the region E as follows,

$$E = \{(x, y, z) \mid (x, y) \in D, u_1(x, y) \leq z \leq u_2(x, y)\}$$

where $(x, y) \in D$ is the notation that means that the point (x, y) lies in the region D from the xy -plane. In this case we will evaluate the triple integral as follows,

$$\iiint_E f(x, y, z) dV = \iint_D \left[\int_{u_1(x, y)}^{u_2(x, y)} f(x, y, z) dz \right] dA$$

where the double integral can be evaluated in any of the methods that we saw in the previous couple of sections. In other words, we can integrate first with respect to x , we can integrate first with respect to y , or we can use polar coordinates as needed.

Example 2 Evaluate $\iiint_E 2x dV$ where E is the region under the plane $2x + 3y + z = 6$ that lies in the first octant.

Solution

We should first define *octant*. Just as the two-dimensional coordinate system can be divided into four quadrants the three-dimensional coordinate system can be divided into eight octants. The first octant is the octant in which all three of the coordinates are positive.

Here is a sketch of the plane in the first octant.

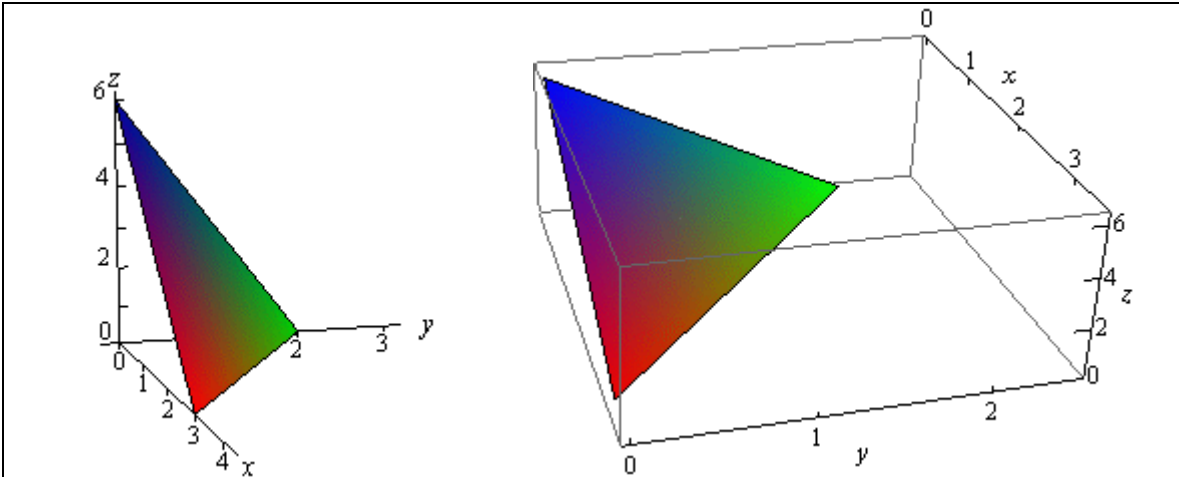

We now need to determine the region D in the xy -plane. We can get a visualization of the region by pretending to look straight down on the object from above. What we see will be the region D in the xy -plane. So D will be the triangle with vertices at $(0,0)$, $(3,0)$, and $(0,2)$. Here is a sketch of D .

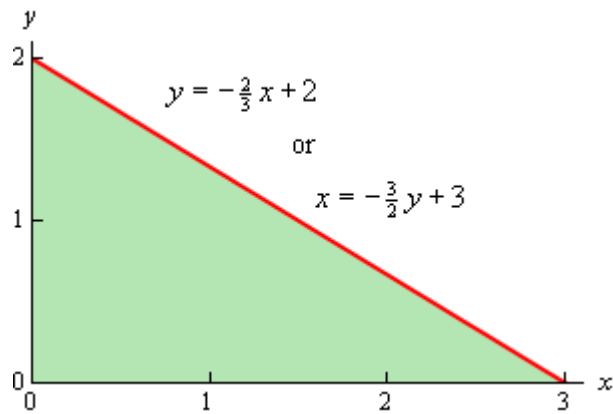

Now we need the limits of integration. Since we are under the plane and in the first octant (so we're above the plane $z = 0$) we have the following limits for z .

$$0 \leq z \leq 6 - 2x - 3y$$

We can integrate the double integral over D using either of the following two sets of inequalities.

$$\begin{array}{l|l} 0 \leq x \leq 3 & 0 \leq x \leq -\frac{3}{2}y + 3 \\ 0 \leq y \leq -\frac{2}{3}x + 2 & 0 \leq y \leq 2 \end{array}$$

Since neither really holds an advantage over the other we'll use the first one. The integral is then,

$$\begin{aligned}
 \iiint_E 2x \, dV &= \iint_D \left[\int_0^{6-2x-3y} 2x \, dz \right] dA \\
 &= \iint_D 2xz \Big|_0^{6-2x-3y} dA \\
 &= \int_0^3 \int_0^{\frac{2}{3}x+2} 2x(6-2x-3y) \, dy \, dx \\
 &= \int_0^3 \left(12xy - 4x^2y - 3xy^2 \right) \Big|_0^{\frac{2}{3}x+2} dx \\
 &= \int_0^3 \frac{4}{3}x^3 - 8x^2 + 12x \, dx \\
 &= \left(\frac{1}{3}x^4 - \frac{8}{3}x^3 + 6x^2 \right) \Big|_0^3 \\
 &= 9
 \end{aligned}$$

Let's now move onto the second possible three-dimensional region we may run into for triple integrals. Here is a sketch of this region.

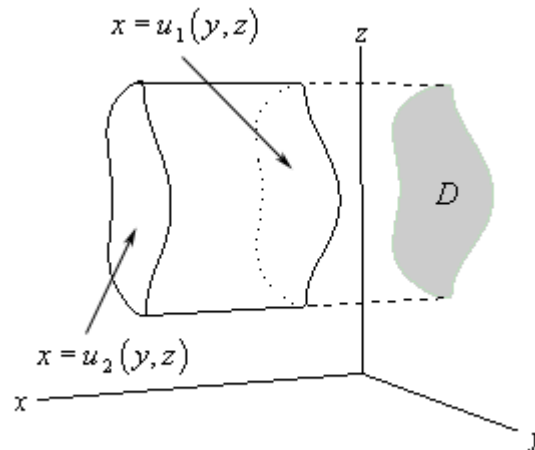

For this possibility we define the region E as follows,

$$E = \{(x, y, z) \mid (y, z) \in D, u_1(y, z) \leq x \leq u_2(y, z)\}$$

So, the region D will be a region in the yz -plane. Here is how we will evaluate these integrals.

$$\iiint_E f(x, y, z) \, dV = \iint_D \left[\int_{u_1(y, z)}^{u_2(y, z)} f(x, y, z) \, dx \right] dA$$

As with the first possibility we will have two options for doing the double integral in the yz -plane as well as the option of using polar coordinates if needed.

Example 3 Determine the volume of the region that lies behind the plane $x + y + z = 8$ and in front of the region in the yz -plane that is bounded by $z = \frac{3}{2}\sqrt{y}$ and $z = \frac{3}{4}y$.

Solution

In this case we've been given D and so we won't have to really work to find that. Here is a sketch of the region D as well as a quick sketch of the plane and the curves defining D projected out past the plane so we can get an idea of what the region we're dealing with looks like.

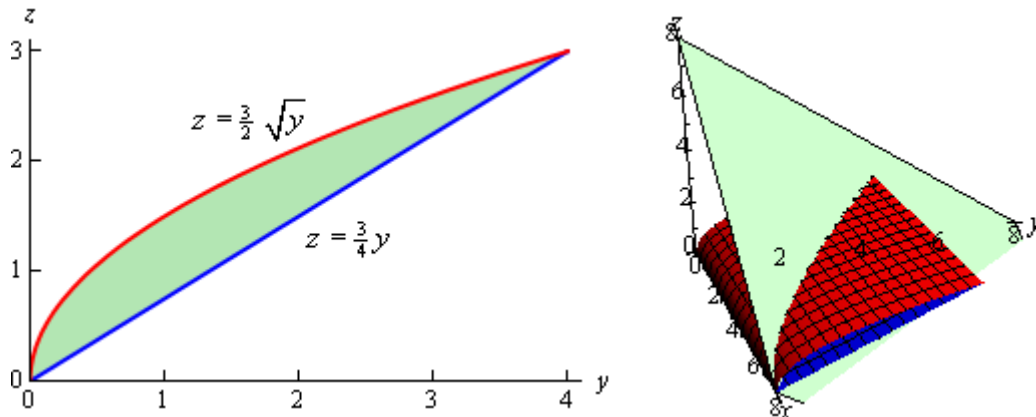

Now, the graph of the region above is all okay, but it doesn't really show us what the region is. So, here is a sketch of the region itself.

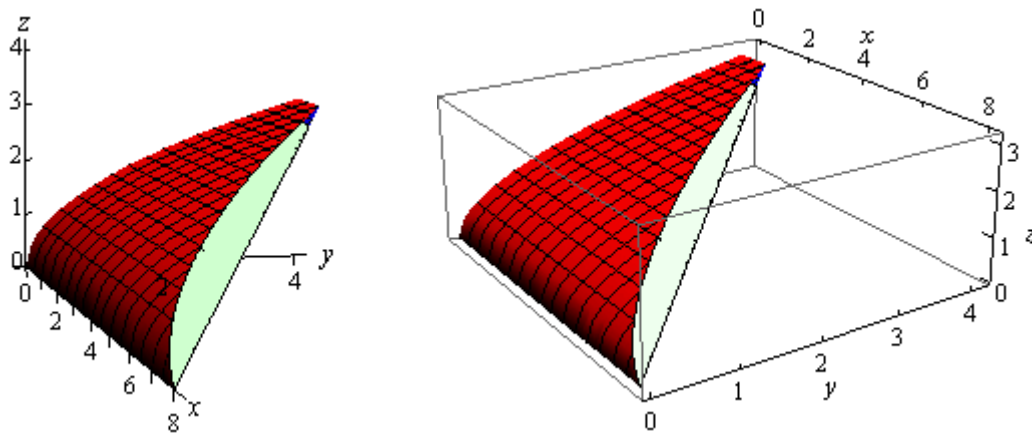

Here are the limits for each of the variables.

$$0 \leq y \leq 4$$

$$\frac{3}{4}y \leq z \leq \frac{3}{2}\sqrt{y}$$

$$0 \leq x \leq 8 - y - z$$

The volume is then,

$$\begin{aligned}
 V &= \iiint_E dV = \iint_D \left[\int_0^{8-y-z} dx \right] dA \\
 &= \int_0^4 \int_{3y/4}^{3\sqrt{y}/2} 8 - y - z \, dz \, dy \\
 &= \int_0^4 \left(8z - yz - \frac{1}{2}z^2 \right) \Big|_{\frac{3y}{4}}^{\frac{3\sqrt{y}}{2}} dy \\
 &= \int_0^4 12y^{\frac{1}{2}} - \frac{57}{8}y - \frac{3}{2}y^{\frac{3}{2}} + \frac{33}{32}y^2 \, dy \\
 &= \left(8y^{\frac{3}{2}} - \frac{57}{16}y^2 - \frac{3}{5}y^{\frac{5}{2}} + \frac{11}{32}y^3 \right) \Big|_0^4 = \frac{49}{5}
 \end{aligned}$$

We now need to look at the third (and final) possible three-dimensional region we may run into for triple integrals. Here is a sketch of this region.

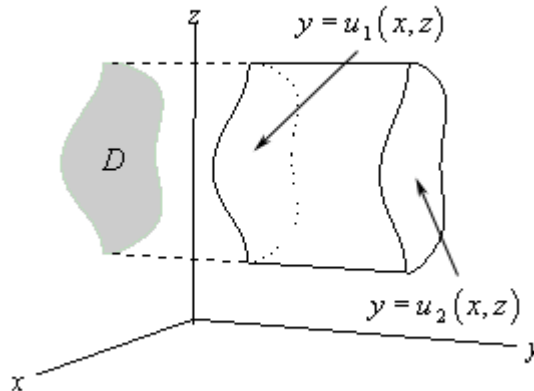

In this final case E is defined as,

$$E = \{(x, y, z) \mid (x, z) \in D, u_1(x, z) \leq y \leq u_2(x, z)\}$$

and here the region D will be a region in the xz -plane. Here is how we will evaluate these integrals.

$$\iiint_E f(x, y, z) dV = \iint_D \left[\int_{u_1(x,z)}^{u_2(x,z)} f(x, y, z) dy \right] dA$$

where we will can use either of the two possible orders for integrating D in the xz -plane or we can use polar coordinates if needed.

Example 4 Evaluate $\iiint_E \sqrt{3x^2 + 3z^2} \, dV$ where E is the solid bounded by $y = 2x^2 + 2z^2$ and the plane $y = 8$.

Solution

Here is a sketch of the solid E .

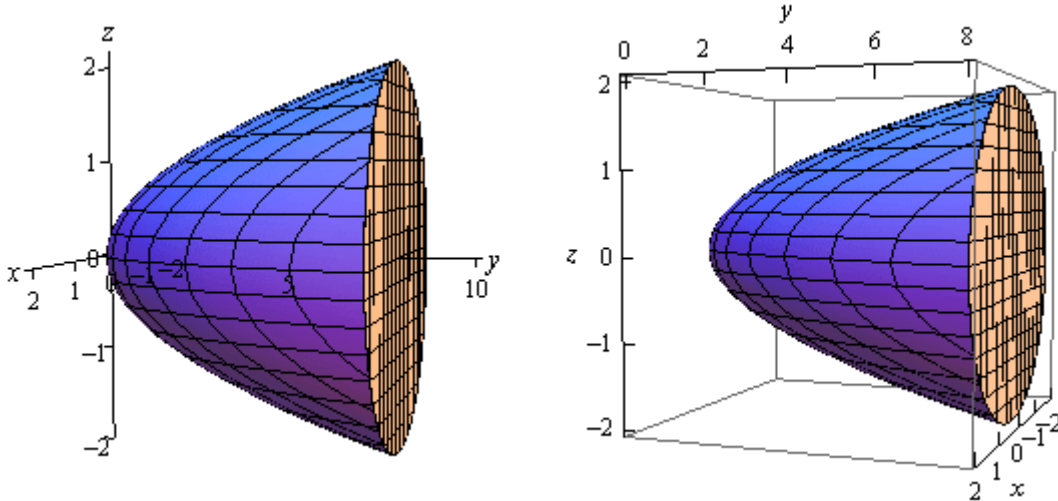

The region D in the xz -plane can be found by “standing” in front of this solid and we can see that D will be a disk in the xz -plane. This disk will come from the front of the solid and we can determine the equation of the disk by setting the elliptic paraboloid and the plane equal.

$$2x^2 + 2z^2 = 8 \quad \Rightarrow \quad x^2 + z^2 = 4$$

This region, as well as the integrand, both seems to suggest that we should use something like polar coordinates. However we are in the xz -plane and we’ve only seen polar coordinates in the xy -plane. This is not a problem. We can always “translate” them over to the xz -plane with the following definition.

$$x = r \cos \theta \qquad z = r \sin \theta$$

Since the region doesn’t have y ’s we will let z take the place of y in all the formulas. Note that these definitions also lead to the formula,

$$x^2 + z^2 = r^2$$

With this in hand we can arrive at the limits of the variables that we’ll need for this integral.

$$2x^2 + 2z^2 \leq y \leq 8$$

$$0 \leq r \leq 2$$

$$0 \leq \theta \leq 2\pi$$

The integral is then,

$$\begin{aligned}
 \iiint_E \sqrt{3x^2 + 3z^2} \, dV &= \iint_D \left[\int_{2x^2+2z^2}^8 \sqrt{3x^2 + 3z^2} \, dy \right] dA \\
 &= \iint_D \left(y\sqrt{3x^2 + 3z^2} \right) \Big|_{2x^2+2z^2}^8 dA \\
 &= \iint_D \sqrt{3(x^2 + z^2)} (8 - (2x^2 + 2z^2)) dA
 \end{aligned}$$

Now, since we are going to do the double integral in polar coordinates let's get everything converted over to polar coordinates. The integrand is,

$$\begin{aligned}
 \sqrt{3(x^2 + z^2)} (8 - (2x^2 + 2z^2)) &= \sqrt{3r^2} (8 - 2r^2) \\
 &= \sqrt{3} r (8 - 2r^2) \\
 &= \sqrt{3} (8r - 2r^3)
 \end{aligned}$$

The integral is then,

$$\begin{aligned}
 \iiint_E \sqrt{3x^2 + 3z^2} \, dV &= \iint_D \sqrt{3} (8r - 2r^3) dA \\
 &= \sqrt{3} \int_0^{2\pi} \int_0^2 (8r - 2r^3) r \, dr \, d\theta \\
 &= \sqrt{3} \int_0^{2\pi} \left(\frac{8}{3} r^3 - \frac{2}{5} r^5 \right) \Big|_0^2 d\theta \\
 &= \sqrt{3} \int_0^{2\pi} \frac{128}{15} d\theta \\
 &= \frac{256\sqrt{3}\pi}{15}
 \end{aligned}$$

Triple Integrals in Cylindrical Coordinates

In this section we want to take a look at triple integrals done completely in Cylindrical Coordinates. [Recall](#) that cylindrical coordinates are really nothing more than an extension of polar coordinates into three dimensions. The following are the conversion formulas for cylindrical coordinates.

$$x = r \cos \theta \quad y = r \sin \theta \quad z = z$$

In order to do the integral in cylindrical coordinates we will need to know what dV will become in terms of cylindrical coordinates. We will be able to show in the [Change of Variables](#) section of this chapter that,

$$dV = r \, dz \, dr \, d\theta$$

The region, E , over which we are integrating becomes,

$$\begin{aligned} E &= \{(x, y, z) \mid (x, y) \in D, u_1(x, y) \leq z \leq u_2(x, y)\} \\ &= \{(r, \theta, z) \mid \alpha \leq \theta \leq \beta, h_1(\theta) \leq r \leq h_2(\theta), u_1(r \cos \theta, r \sin \theta) \leq z \leq u_2(r \cos \theta, r \sin \theta)\} \end{aligned}$$

Note that we've only given this for E 's in which D is in the xy -plane. We can modify this accordingly if D is in the yz -plane or the xz -plane as needed.

In terms of cylindrical coordinates a triple integral is,

$$\iiint_E f(x, y, z) \, dV = \int_{\alpha}^{\beta} \int_{h_1(\theta)}^{h_2(\theta)} \int_{u_1(r \cos \theta, r \sin \theta)}^{u_2(r \cos \theta, r \sin \theta)} r f(r \cos \theta, r \sin \theta, z) \, dz \, dr \, d\theta$$

Don't forget to add in the r and make sure that all the x 's and y 's also get converted over into cylindrical coordinates.

Let's see an example.

Example 1 Evaluate $\iiint_E y \, dV$ where E is the region that lies below the plane $z = x + 2$ above the xy -plane and between the cylinders $x^2 + y^2 = 1$ and $x^2 + y^2 = 4$.

Solution

There really isn't too much to do with this one other than do the conversions and then evaluate the integral.

We'll start out by getting the range for z in terms of cylindrical coordinates.

$$0 \leq z \leq x + 2 \quad \Rightarrow \quad 0 \leq z \leq r \cos \theta + 2$$

Remember that we are above the xy -plane and so we are above the plane $z = 0$

Next, the region D is the region between the two circles $x^2 + y^2 = 1$ and $x^2 + y^2 = 4$ in the xy -plane and so the ranges for it are,

$$0 \leq \theta \leq 2\pi \quad 1 \leq r \leq 2$$

Here is the integral.

$$\begin{aligned}
 \iiint_E y \, dV &= \int_0^{2\pi} \int_1^2 \int_0^{r \cos \theta + 2} (r \sin \theta) r \, dz \, dr \, d\theta \\
 &= \int_0^{2\pi} \int_1^2 r^2 \sin \theta (r \cos \theta + 2) \, dr \, d\theta \\
 &= \int_0^{2\pi} \int_1^2 \frac{1}{2} r^3 \sin(2\theta) + 2r^2 \sin \theta \, dr \, d\theta \\
 &= \int_0^{2\pi} \left(\frac{1}{8} r^4 \sin(2\theta) + \frac{2}{3} r^3 \sin \theta \right) \Big|_1^2 \, d\theta \\
 &= \int_0^{2\pi} \frac{15}{8} \sin(2\theta) + \frac{14}{3} \sin \theta \, d\theta \\
 &= \left(-\frac{15}{16} \cos(2\theta) - \frac{14}{3} \cos \theta \right) \Big|_0^{2\pi} \\
 &= 0
 \end{aligned}$$

Just as we did with double integral involving polar coordinates we can start with an iterated integral in terms of x , y , and z and convert it to cylindrical coordinates.

Example 2 Convert $\int_{-1}^1 \int_0^{\sqrt{1-y^2}} \int_{x^2+y^2}^{\sqrt{x^2+y^2}} xyz \, dz \, dx \, dy$ into an integral in cylindrical coordinates.

Solution

Here are the ranges of the variables from this iterated integral.

$$\begin{aligned}
 -1 &\leq y \leq 1 \\
 0 &\leq x \leq \sqrt{1-y^2} \\
 x^2 + y^2 &\leq z \leq \sqrt{x^2 + y^2}
 \end{aligned}$$

The first two inequalities define the region D and since the upper and lower bounds for the x 's are $x = \sqrt{1-y^2}$ and $x = 0$ we know that we've got at least part of the right half a circle of radius 1 centered at the origin. Since the range of y 's is $-1 \leq y \leq 1$ we know that we have the complete right half of the disk of radius 1 centered at the origin. So, the ranges for D in cylindrical coordinates are,

$$\begin{aligned}
 -\frac{\pi}{2} &\leq \theta \leq \frac{\pi}{2} \\
 0 &\leq r \leq 1
 \end{aligned}$$

All that's left to do now is to convert the limits of the z range, but that's not too bad.

$$r^2 \leq z \leq r$$

On a side note notice that the lower bound here is an elliptic paraboloid and the upper bound is a cone. Therefore E is a portion of the region between these two surfaces.

The integral is,

$$\begin{aligned}\int_{-1}^1 \int_0^{\sqrt{1-y^2}} \int_{x^2+y^2}^{\sqrt{x^2+y^2}} xyz \, dz \, dx \, dy &= \int_{-\pi/2}^{\pi/2} \int_0^1 \int_{r^2}^r r(r \cos \theta)(r \sin \theta) z \, dz \, dr \, d\theta \\ &= \int_{-\pi/2}^{\pi/2} \int_0^1 \int_{r^2}^r zr^3 \cos \theta \sin \theta \, dz \, dr \, d\theta\end{aligned}$$

Triple Integrals in Spherical Coordinates

In the previous section we looked at doing integrals in terms of cylindrical coordinates and we now need to take a quick look at doing integrals in terms of spherical coordinates.

First, we need to [recall](#) just how spherical coordinates are defined. The following sketch shows the relationship between the Cartesian and spherical coordinate systems.

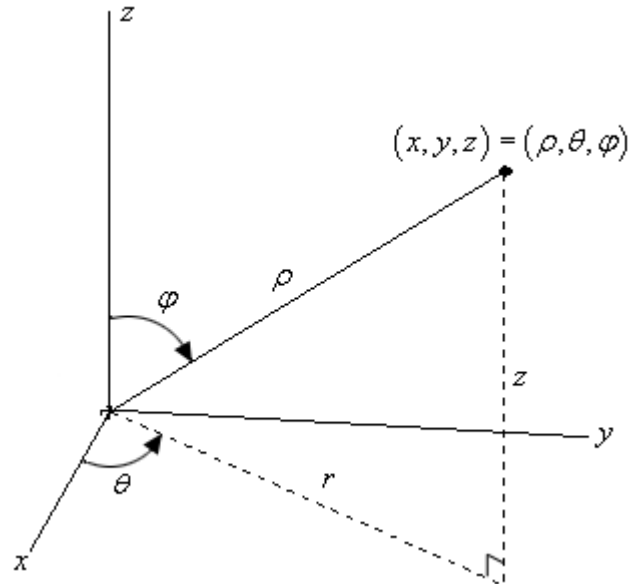

Here are the conversion formulas for spherical coordinates.

$$\begin{aligned} x &= \rho \sin \varphi \cos \theta & y &= \rho \sin \varphi \sin \theta & z &= \rho \cos \varphi \\ x^2 + y^2 + z^2 &= \rho^2 \end{aligned}$$

We also have the following restrictions on the coordinates.

$$\rho \geq 0 \qquad 0 \leq \varphi \leq \pi$$

For our integrals we are going to restrict E down to a spherical wedge. This will mean that we are going to take ranges for the variables as follows,

$$\begin{aligned} a &\leq \rho \leq b \\ \alpha &\leq \theta \leq \beta \\ \delta &\leq \varphi \leq \gamma \end{aligned}$$

Here is a quick sketch of a spherical wedge in which the lower limit for both ρ and φ are zero for reference purposes. Most of the wedges we'll be working with will fit into this pattern.

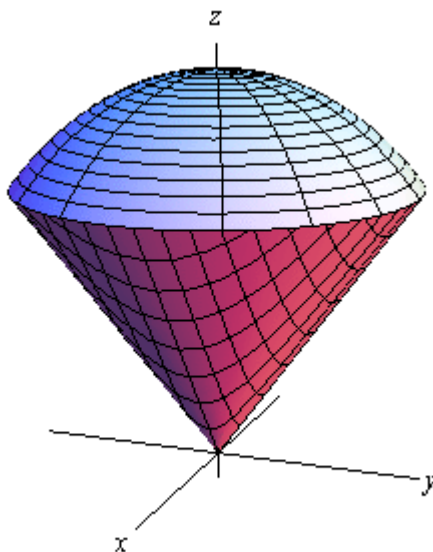

From this sketch we can see that E is really nothing more than the intersection of a sphere and a cone.

In the next [section](#) we will show that

$$dV = \rho^2 \sin \varphi \, d\rho \, d\theta \, d\varphi$$

Therefore the integral will become,

$$\iiint_E f(x, y, z) \, dV = \int_{\delta}^{\gamma} \int_{\alpha}^{\beta} \int_a^b \rho^2 \sin \varphi \, f(\rho \sin \varphi \cos \theta, \rho \sin \varphi \sin \theta, \rho \cos \varphi) \, d\rho \, d\theta \, d\varphi$$

This looks bad, but given that the limits are all constants the integrals here tend to not be too bad.

Example 1 Evaluate $\iiint_E 16z \, dV$ where E is the upper half of the sphere $x^2 + y^2 + z^2 = 1$.

Solution

Since we are taking the upper half of the sphere the limits for the variables are,

$$0 \leq \rho \leq 1$$

$$0 \leq \theta \leq 2\pi$$

$$0 \leq \varphi \leq \frac{\pi}{2}$$

The integral is then,

$$\begin{aligned}
\iiint_E 16z \, dV &= \int_0^{\frac{\pi}{2}} \int_0^{2\pi} \int_0^1 \rho^2 \sin \varphi (16\rho \cos \varphi) \, d\rho \, d\theta \, d\varphi \\
&= \int_0^{\frac{\pi}{2}} \int_0^{2\pi} \int_0^1 8\rho^3 \sin(2\varphi) \, d\rho \, d\theta \, d\varphi \\
&= \int_0^{\frac{\pi}{2}} \int_0^{2\pi} 2 \sin(2\varphi) \, d\theta \, d\varphi \\
&= \int_0^{\frac{\pi}{2}} 4\pi \sin(2\varphi) \, d\varphi \\
&= -2\pi \cos(2\varphi) \Big|_0^{\frac{\pi}{2}} \\
&= 4\pi
\end{aligned}$$

Example 2 Convert $\int_0^3 \int_0^{\sqrt{9-y^2}} \int_{\sqrt{x^2+y^2}}^{\sqrt{18-x^2-y^2}} x^2 + y^2 + z^2 \, dz \, dx \, dy$ into spherical coordinates.

Solution

Let's first write down the limits for the variables.

$$\begin{aligned}
0 &\leq y \leq 3 \\
0 &\leq x \leq \sqrt{9-y^2} \\
\sqrt{x^2+y^2} &\leq z \leq \sqrt{18-x^2-y^2}
\end{aligned}$$

The range for x tells us that we have a portion of the right half of a disk of radius 3 centered at the origin. Since we are restricting y 's to positive values it looks like we will have the quarter disk in the first quadrant. Therefore since D is in the first quadrant the region, E , must be in the first octant and this in turn tells us that we have the following range for θ (since this is the angle around the z -axis).

$$0 \leq \theta \leq \frac{\pi}{2}$$

Now, let's see what the range for z tells us. The lower bound, $z = \sqrt{x^2 + y^2}$, is the upper half of a cone. At this point we don't need this quite yet, but we will later. The upper bound,

$z = \sqrt{18 - x^2 - y^2}$, is the upper half of the sphere,

$$x^2 + y^2 + z^2 = 18$$

and so from this we now have the following range for ρ

$$0 \leq \rho \leq \sqrt{18} = 3\sqrt{2}$$

Now all that we need is the range for φ . There are two ways to get this. One is from where the cone and the sphere intersect. Plugging in the equation for the cone into the sphere gives,

$$\left(\sqrt{x^2 + y^2}\right)^2 + z^2 = 18$$

$$z^2 + z^2 = 18$$

$$z^2 = 9$$

$$z = 3$$

Note that we can assume z is positive here since we know that we have the upper half of the cone and/or sphere. Finally, plug this into the conversion for z and take advantage of the fact that we know that $\rho = 3\sqrt{2}$ since we are intersecting on the sphere. This gives,

$$\rho \cos \varphi = 3$$

$$3\sqrt{2} \cos \varphi = 3$$

$$\cos \varphi = \frac{1}{\sqrt{2}} = \frac{\sqrt{2}}{2} \quad \Rightarrow \quad \varphi = \frac{\pi}{4}$$

So, it looks like we have the following range,

$$0 \leq \varphi \leq \frac{\pi}{4}$$

The other way to get this range is from the cone by itself. By first converting the equation into cylindrical coordinates and then into spherical coordinates we get the following,

$$z = r$$

$$\rho \cos \varphi = \rho \sin \varphi$$

$$1 = \tan \varphi \quad \Rightarrow \quad \varphi = \frac{\pi}{4}$$

So, recalling that $\rho^2 = x^2 + y^2 + z^2$, the integral is then,

$$\int_0^3 \int_0^{\sqrt{9-y^2}} \int_{\sqrt{x^2+y^2}}^{\sqrt{18-x^2-y^2}} x^2 + y^2 + z^2 \, dz \, dx \, dy = \int_0^{\pi/4} \int_0^{\pi/2} \int_0^{3\sqrt{2}} \rho^4 \sin \varphi \, d\rho \, d\theta \, d\varphi$$

Change of Variables

Back in Calculus I we had the substitution rule that told us that,

$$\int_a^b f(g(x))g'(x)dx = \int_c^d f(u)du \quad \text{where } u = g(x)$$

In essence this is taking an integral in terms of x 's and changing it into terms of u 's. We want to do something similar for double and triple integrals. In fact we've already done this to a certain extent when we converted double integrals to polar coordinates and when we converted triple integrals to cylindrical or spherical coordinates. The main difference is that we didn't actually go through the details of where the formulas came from. If you recall, in each of those cases we commented that we would justify the formulas for dA and dV eventually. Now is the time to do that justification.

While often the reason for changing variables is to get us an integral that we can do with the new variables, another reason for changing variables is to convert the region into a nicer region to work with. When we were converting the polar, cylindrical or spherical coordinates we didn't worry about this change since it was easy enough to determine the new limits based on the given region. That is not always the case however. So, before we move into changing variables with multiple integrals we first need to see how the region may change with a change of variables.

First we need a little notation out of the way. We call the equations that define the change of variables a **transformation**. Also we will typically start out with a region, R , in xy -coordinates and transform it into a region in uv -coordinates.

Example 1 Determine the new region that we get by applying the given transformation to the region R .

(a) R is the ellipse $x^2 + \frac{y^2}{36} = 1$ and the transformation is $x = \frac{u}{2}$, $y = 3v$. [\[Solution\]](#)

(b) R is the region bounded by $y = -x + 4$, $y = x + 1$, and $y = \frac{x}{3} - \frac{4}{3}$ and the

transformation is $x = \frac{1}{2}(u + v)$, $y = \frac{1}{2}(u - v)$. [\[Solution\]](#)

Solution

(a) **R is the ellipse $x^2 + \frac{y^2}{36} = 1$ and the transformation is $x = \frac{u}{2}$, $y = 3v$.**

There really isn't too much to do with this one other than to plug the transformation into the equation for the ellipse and see what we get.

$$\begin{aligned} \left(\frac{u}{2}\right)^2 + \frac{(3v)^2}{36} &= 1 \\ \frac{u^2}{4} + \frac{9v^2}{36} &= 1 \\ u^2 + v^2 &= 4 \end{aligned}$$

So, we started out with an ellipse and after the transformation we had a disk of radius 2.

[\[Return to Problems\]](#)

(b) R is the region bounded by $y = -x + 4$, $y = x + 1$, and $y = \frac{x}{3} - \frac{4}{3}$ and the

transformation is $x = \frac{1}{2}(u + v)$, $y = \frac{1}{2}(u - v)$.

As with the first part we'll need to plug the transformation into the equation, however, in this case we will need to do it three times, once for each equation. Before we do that let's sketch the graph of the region and see what we've got.

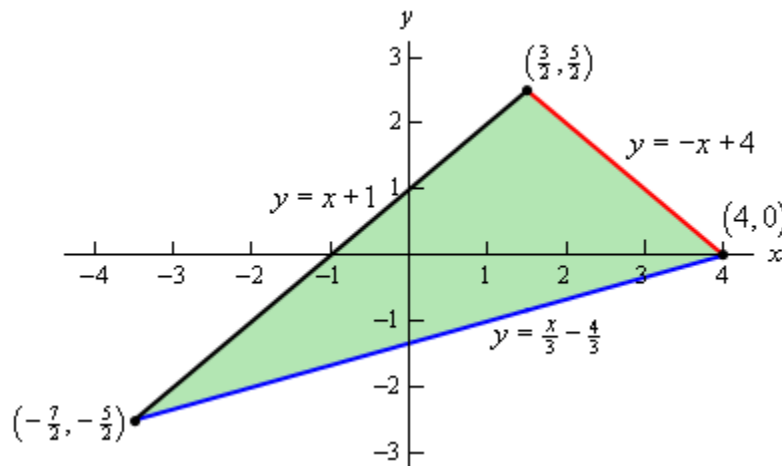

So, we have a triangle. Now, let's go through the transformation. We will apply the transformation to each edge of the triangle and see where we get.

Let's do $y = -x + 4$ first. Plugging in the transformation gives,

$$\frac{1}{2}(u - v) = -\frac{1}{2}(u + v) + 4$$

$$u - v = -u - v + 8$$

$$2u = 8$$

$$u = 4$$

The first boundary transforms very nicely into a much simpler equation.

Now let's take a look at $y = x + 1$,

$$\frac{1}{2}(u - v) = \frac{1}{2}(u + v) + 1$$

$$u - v = u + v + 2$$

$$-2v = 2$$

$$v = -1$$

Again, a much nicer equation than what we started with.

Finally, let's transform $y = \frac{x}{3} - \frac{4}{3}$.

$$\frac{1}{2}(u-v) = \frac{1}{3}\left(\frac{1}{2}(u+v)\right) - \frac{4}{3}$$

$$3u - 3v = u + v - 8$$

$$4v = 2u + 8$$

$$v = \frac{u}{2} + 2$$

So, again, we got a somewhat simpler equation, although not quite as nice as the first two.

Let's take a look at the new region that we get under the transformation.

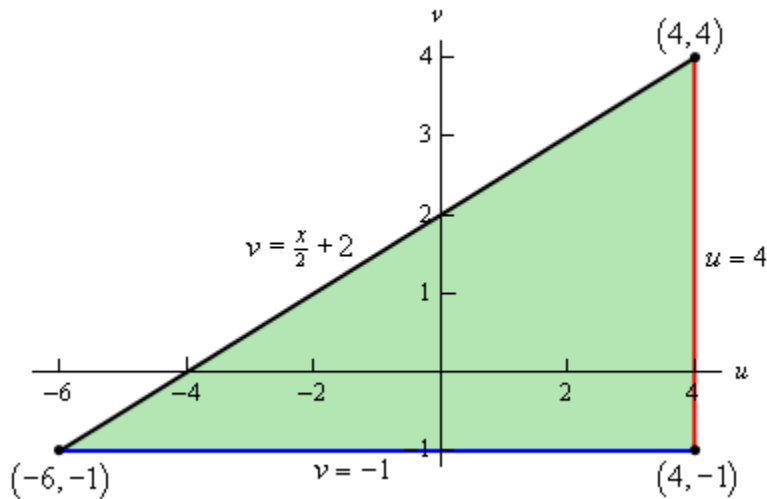

We still get a triangle, but a much nicer one.

[\[Return to Problems\]](#)

Note that we can't always expect to transform a specific type of region (a triangle for example) into the same kind of region. It is completely possible to have a triangle transform into a region in which each of the edges are curved and in no way resembles a triangle.

Notice that in each of the above examples we took a two dimensional region that would have been somewhat difficult to integrate over and converted it into a region that would be much nicer in integrate over. As we noted at the start of this set of examples, that is often one of the points behind the transformation. In addition to converting the integrand into something simpler it will often also transform the region into one that is much easier to deal with.

Now that we've seen a couple of examples of transforming regions we need to now talk about how we actually do change of variables in the integral. We will start with double integrals. In order to change variables in a double integral we will need the **Jacobian** of the transformation. Here is the definition of the Jacobian.

Definition

The **Jacobian** of the transformation $x = g(u, v)$, $y = h(u, v)$ is

$$\frac{\partial(x, y)}{\partial(u, v)} = \begin{vmatrix} \frac{\partial x}{\partial u} & \frac{\partial x}{\partial v} \\ \frac{\partial y}{\partial u} & \frac{\partial y}{\partial v} \end{vmatrix}$$

The Jacobian is defined as a determinant of a 2x2 matrix, if you are unfamiliar with this that is okay. Here is how to compute the determinant.

$$\begin{vmatrix} a & b \\ c & d \end{vmatrix} = ad - bc$$

Therefore, another formula for the determinant is,

$$\frac{\partial(x, y)}{\partial(u, v)} = \begin{vmatrix} \frac{\partial x}{\partial u} & \frac{\partial x}{\partial v} \\ \frac{\partial y}{\partial u} & \frac{\partial y}{\partial v} \end{vmatrix} = \frac{\partial x}{\partial u} \frac{\partial y}{\partial v} - \frac{\partial x}{\partial v} \frac{\partial y}{\partial u}$$

Now that we have the Jacobian out of the way we can give the formula for change of variables for a double integral.

Change of Variables for a Double Integral

Suppose that we want to integrate $f(x, y)$ over the region R . Under the transformation $x = g(u, v)$, $y = h(u, v)$ the region becomes S and the integral becomes,

$$\iint_D f(x, y) dA = \iint_S f(g(u, v), h(u, v)) \left| \frac{\partial(x, y)}{\partial(u, v)} \right| du dv$$

Note that we used $du dv$ instead of dA in the integral to make it clear that we are now integrating with respect to u and v . Also note that we are taking the absolute value of the Jacobian.

If we look just at the differentials in the above formula we can also say that

$$dA = \left| \frac{\partial(x, y)}{\partial(u, v)} \right| du dv$$

Example 2 Show that when changing to polar coordinates we have $dA = r dr d\theta$

Solution

So, what we are doing here is justifying the formula that we used back when we were integrating with respect to [polar coordinates](#). All that we need to do is use the formula above for dA .

The transformation here is the standard conversion formulas,

$$x = r \cos \theta \qquad y = r \sin \theta$$

The Jacobian for this transformation is,

$$\begin{aligned} \frac{\partial(x, y)}{\partial(r, \theta)} &= \begin{vmatrix} \frac{\partial x}{\partial r} & \frac{\partial x}{\partial \theta} \\ \frac{\partial y}{\partial r} & \frac{\partial y}{\partial \theta} \end{vmatrix} \\ &= \begin{vmatrix} \cos \theta & -r \sin \theta \\ \sin \theta & r \cos \theta \end{vmatrix} \\ &= r \cos^2 \theta - (-r \sin^2 \theta) \\ &= r(\cos^2 \theta + \sin^2 \theta) \\ &= r \end{aligned}$$

We then get,

$$dA = \left| \frac{\partial(x, y)}{\partial(r, \theta)} \right| dr d\theta = |r| dr d\theta = r dr d\theta$$

So, the formula we used in the section on polar integrals was correct.

Now, let's do a couple of integrals.

Example 3 Evaluate $\iint_R x + y dA$ where R is the trapezoidal region with vertices given by $(0, 0)$, $(5, 0)$, $(\frac{5}{2}, \frac{5}{2})$ and $(\frac{5}{2}, -\frac{5}{2})$ using the transformation $x = 2u + 3v$ and $y = 2u - 3v$.

Solution

First, let's sketch the region R and determine equations for each of the sides.

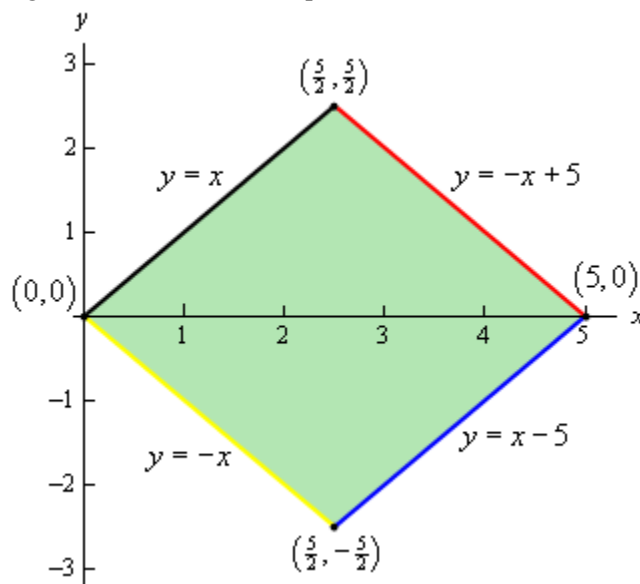

Each of the equations was found by using the fact that we know two points on each line (*i.e.* the two vertices that form the edge).

While we could do this integral in terms of x and y it would involve two integrals and so would be some work.

Let's use the transformation and see what we get. We'll do this by plugging the transformation into each of the equations above.

Let's start the process off with $y = x$.

$$2u - 3v = 2u + 3v$$

$$6v = 0$$

$$v = 0$$

Transforming $y = -x$ is similar.

$$2u - 3v = -(2u + 3v)$$

$$4u = 0$$

$$u = 0$$

Next we'll transform $y = -x + 5$.

$$2u - 3v = -(2u + 3v) + 5$$

$$4u = 5$$

$$u = \frac{5}{4}$$

Finally, let's transform $y = x - 5$.

$$2u - 3v = 2u + 3v - 5$$

$$-6v = -5$$

$$v = \frac{5}{6}$$

The region S is then a rectangle whose sides are given by $u = 0$, $v = 0$, $u = \frac{5}{4}$ and $v = \frac{5}{6}$ and so the ranges of u and v are,

$$0 \leq u \leq \frac{5}{4} \qquad 0 \leq v \leq \frac{5}{6}$$

Next, we need the Jacobian.

$$\frac{\partial(x, y)}{\partial(u, v)} = \begin{vmatrix} 2 & 3 \\ 2 & -3 \end{vmatrix} = -6 - 6 = -12$$

The integral is then,

$$\begin{aligned}
\iint_R x + y \, dA &= \int_0^{\frac{5}{6}} \int_0^{\frac{5}{4}} ((2u + 3v) + (2u - 3v)) | -12 | \, du \, dv \\
&= \int_0^{\frac{5}{6}} \int_0^{\frac{5}{4}} 48u \, du \, dv \\
&= \int_0^{\frac{5}{6}} 24u^2 \Big|_0^{\frac{5}{4}} \, dv \\
&= \int_0^{\frac{5}{6}} \frac{75}{2} \, dv \\
&= \frac{75}{2} v \Big|_0^{\frac{5}{6}} \\
&= \frac{125}{4}
\end{aligned}$$

Example 4 Evaluate $\iint_R x^2 - xy + y^2 \, dA$ where R is the ellipse given by $x^2 - xy + y^2 = 2$ and

using the transformation $x = \sqrt{2}u - \sqrt{\frac{2}{3}}v$, $y = \sqrt{2}u + \sqrt{\frac{2}{3}}v$.

Solution

The first thing to do is to plug the transformation into the equation for the ellipse to see what the region transforms into.

$$\begin{aligned}
2 &= x^2 - xy + y^2 \\
&= \left(\sqrt{2}u - \sqrt{\frac{2}{3}}v \right)^2 - \left(\sqrt{2}u - \sqrt{\frac{2}{3}}v \right) \left(\sqrt{2}u + \sqrt{\frac{2}{3}}v \right) + \left(\sqrt{2}u + \sqrt{\frac{2}{3}}v \right)^2 \\
&= 2u^2 - \frac{4}{\sqrt{3}}uv + \frac{2}{3}v^2 - \left(2u^2 - \frac{2}{3}v^2 \right) + 2u^2 + \frac{4}{\sqrt{3}}uv + \frac{2}{3}v^2 \\
&= 2u^2 + 2v^2
\end{aligned}$$

Or, upon dividing by 2 we see that the equation describing R transforms into

$$u^2 + v^2 = 1$$

or the unit circle. Again, this will be much easier to integrate over than the original region.

Note as well that we've shown that the function that we're integrating is

$$x^2 - xy + y^2 = 2(u^2 + v^2)$$

in terms of u and v so we won't have to redo that work when the time to do the integral comes around.

Finally, we need to find the Jacobian.

$$\frac{\partial(x, y)}{\partial(u, v)} = \begin{vmatrix} \sqrt{2} & -\sqrt{\frac{2}{3}} \\ \sqrt{2} & \sqrt{\frac{2}{3}} \end{vmatrix} = \frac{2}{\sqrt{3}} + \frac{2}{\sqrt{3}} = \frac{4}{\sqrt{3}}$$

The integral is then,

$$\iint_R x^2 - xy + y^2 dA = \iint_S 2(u^2 + v^2) \left| \frac{4}{\sqrt{3}} \right| du dv$$

Before proceeding a word of caution is in order. Do not make the mistake of substituting $x^2 - xy + y^2 = 2$ or $u^2 + v^2 = 1$ in for the integrands. These equations are only valid on the boundary of the region and we are looking at all the points interior to the boundary as well and for those points neither of these equations will be true!

At this point we'll note that this integral will be much easier in terms of polar coordinates and so to finish the integral out will convert to polar coordinates.

$$\begin{aligned} \iint_R x^2 - xy + y^2 dA &= \iint_S 2(u^2 + v^2) \left| \frac{4}{\sqrt{3}} \right| du dv \\ &= \frac{8}{\sqrt{3}} \int_0^{2\pi} \int_0^1 (r^2) r dr d\theta \\ &= \frac{8}{\sqrt{3}} \int_0^{2\pi} \frac{1}{4} r^4 \Big|_0^1 d\theta \\ &= \frac{8}{\sqrt{3}} \int_0^{2\pi} \frac{1}{4} d\theta \\ &= \frac{4\pi}{\sqrt{3}} \end{aligned}$$

Let's now briefly look at triple integrals. In this case we will again start with a region R and use the transformation $x = g(u, v, w)$, $y = h(u, v, w)$, and $z = k(u, v, w)$ to transform the region into the new region S . To do the integral we will need a Jacobian, just as we did with double integrals. Here is the definition of the Jacobian for this kind of transformation.

$$\frac{\partial(x, y, z)}{\partial(u, v, w)} = \begin{vmatrix} \frac{\partial x}{\partial u} & \frac{\partial x}{\partial v} & \frac{\partial x}{\partial w} \\ \frac{\partial y}{\partial u} & \frac{\partial y}{\partial v} & \frac{\partial y}{\partial w} \\ \frac{\partial z}{\partial u} & \frac{\partial z}{\partial v} & \frac{\partial z}{\partial w} \end{vmatrix}$$

In this case the Jacobian is defined in terms of the determinant of a 3x3 matrix. We saw how to evaluate these when we looked at [cross products](#) back in Calculus II. If you need a refresher on how to compute them you should go back and review that section.

The integral under this transformation is,

$$\iiint_R f(x, y, z) dV = \iiint_S f(g(u, v, w), h(u, v, w), k(u, v, w)) \left| \frac{\partial(x, y, z)}{\partial(u, v, w)} \right| du dv dw$$

As with double integrals we can look at just the differentials and note that we must have

$$dV = \left| \frac{\partial(x, y, z)}{\partial(u, v, w)} \right| du dv dw$$

We're not going to do any integrals here, but let's verify the formula for dV for spherical coordinates.

Example 5 Verify that $dV = \rho^2 \sin \varphi d\rho d\theta d\varphi$ when using spherical coordinates.

Solution

Here the transformation is just the standard conversion formulas.

$$x = \rho \sin \varphi \cos \theta \quad y = \rho \sin \varphi \sin \theta \quad z = \rho \cos \varphi$$

The Jacobian is,

$$\begin{aligned} \frac{\partial(x, y, z)}{\partial(\rho, \theta, \varphi)} &= \begin{vmatrix} \sin \varphi \cos \theta & -\rho \sin \varphi \sin \theta & \rho \cos \varphi \cos \theta \\ \sin \varphi \sin \theta & \rho \sin \varphi \cos \theta & \rho \cos \varphi \sin \theta \\ \cos \varphi & 0 & -\rho \sin \varphi \end{vmatrix} \\ &= -\rho^2 \sin^3 \varphi \cos^2 \theta - \rho^2 \sin \varphi \cos^2 \varphi \sin^2 \theta + 0 \\ &\quad -\rho^2 \sin^3 \varphi \sin^2 \theta - 0 - \rho^2 \sin \varphi \cos^2 \varphi \cos^2 \theta \\ &= -\rho^2 \sin^3 \varphi (\cos^2 \theta + \sin^2 \theta) - \rho^2 \sin \varphi \cos^2 \varphi (\sin^2 \theta + \cos^2 \theta) \\ &= -\rho^2 \sin^3 \varphi - \rho^2 \sin \varphi \cos^2 \varphi \\ &= -\rho^2 \sin \varphi (\sin^2 \varphi + \cos^2 \varphi) \\ &= -\rho^2 \sin \varphi \end{aligned}$$

Finally, dV becomes,

$$dV = \left| -\rho^2 \sin \varphi \right| d\rho d\theta d\varphi = \rho^2 \sin \varphi d\rho d\theta d\varphi$$

Recall that we restricted φ to the range $0 \leq \varphi \leq \pi$ for spherical coordinates and so we know that $\sin \varphi \geq 0$ and so we don't need the absolute value bars on the sine.

We will leave it to you to check the formula for dV for cylindrical coordinates if you'd like to. It is a much easier formula to check.

Surface Area

In this section we will look at the lone application (aside from the area and volume interpretations) of multiple integrals in this material. This is not the first time that we've looked at surface area. We first saw surface area in [Calculus II](#), however, in that setting we were looking at the surface area of a solid of revolution. In other words we were looking at the surface area of a solid obtained by rotating a function about the x or y axis. In this section we want to look at a much more general setting although you will note that the formula here is very similar to the formula we saw back in Calculus II.

Here we want to find the surface area of the surface given by $z = f(x, y)$ where (x, y) is a point from the region D in the xy -plane. In this case the surface area is given by,

$$S = \iint_D \sqrt{[f_x]^2 + [f_y]^2 + 1} dA$$

Let's take a look at a couple of examples.

Example 1 Find the surface area of the part of the plane $3x + 2y + z = 6$ that lies in the first octant.

Solution

Remember that the first octant is the portion of the xyz -axis system in which all three variables are positive. Let's first get a sketch of the part of the plane that we are interested in.

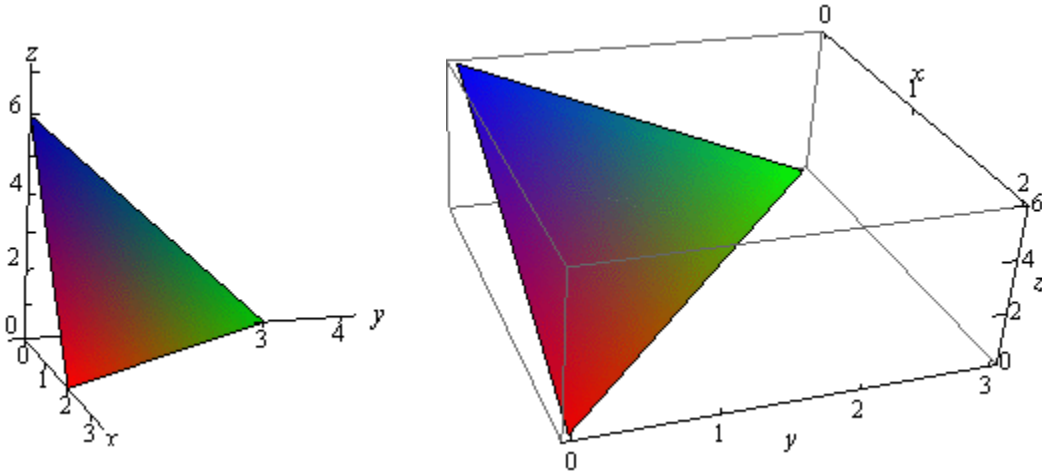

We'll also need a sketch of the region D .

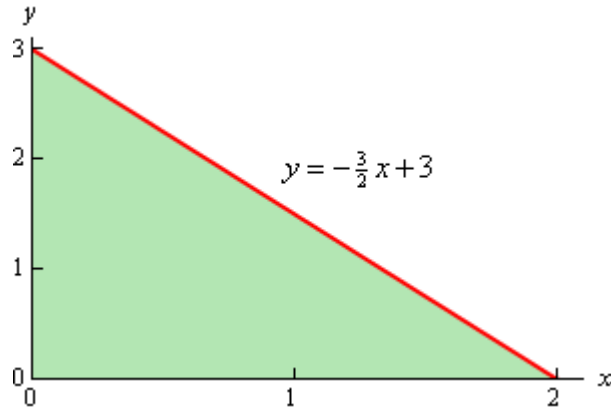

Remember that to get the region D we can pretend that we are standing directly over the plane and what we see is the region D . We can get the equation for the hypotenuse of the triangle by realizing that this is nothing more than the line where the plane intersects the xy -plane and we also know that $z = 0$ on the xy -plane. Plugging $z = 0$ into the equation of the plane will give us the equation for the hypotenuse.

Notice that in order to use the surface area formula we need to have the function in the form $z = f(x, y)$ and so solving for z and taking the partial derivatives gives,

$$z = 6 - 3x - 2y \qquad f_x = -3 \qquad f_y = -2$$

The limits defining D are,

$$0 \leq x \leq 2 \qquad 0 \leq y \leq -\frac{3}{2}x + 3$$

The surface area is then,

$$\begin{aligned} S &= \iint_D \sqrt{[-3]^2 + [-2]^2 + 1} \, dA \\ &= \int_0^2 \int_0^{-\frac{3}{2}x+3} \sqrt{14} \, dy \, dx \\ &= \sqrt{14} \int_0^2 -\frac{3}{2}x + 3 \, dx \\ &= \sqrt{14} \left(-\frac{3}{4}x^2 + 3x \right) \Big|_0^2 \\ &= 3\sqrt{14} \end{aligned}$$

Example 2 Determine the surface area of the part of $z = xy$ that lies in the cylinder given by $x^2 + y^2 = 1$.

Solution

In this case we are looking for the surface area of the part of $z = xy$ where (x, y) comes from the disk of radius 1 centered at the origin since that is the region that will lie inside the given

cylinder.

Here are the partial derivatives,

$$f_x = y \qquad f_y = x$$

The integral for the surface area is,

$$S = \iint_D \sqrt{x^2 + y^2 + 1} \, dA$$

Given that D is a disk it makes sense to do this integral in polar coordinates.

$$\begin{aligned} S &= \iint_D \sqrt{x^2 + y^2 + 1} \, dA \\ &= \int_0^{2\pi} \int_0^1 r \sqrt{1+r^2} \, dr \, d\theta \\ &= \int_0^{2\pi} \frac{1}{2} \left(\frac{2}{3} \right) (1+r^2)^{\frac{3}{2}} \Big|_0^1 \, d\theta \\ &= \int_0^{2\pi} \frac{1}{3} \left(2^{\frac{3}{2}} - 1 \right) \, d\theta \\ &= \frac{2\pi}{3} \left(2^{\frac{3}{2}} - 1 \right) \end{aligned}$$

Area and Volume Revisited

This section is here only so we can summarize the geometric interpretations of the double and triple integrals that we saw in this chapter. Since the purpose of this section is to summarize these formulas we aren't going to be doing any examples in this section.

We'll first look at the area of a region. The area of the region D is given by,

$$\text{Area of } D = \iint_D dA$$

Now let's give the two volume formulas. First the volume of the region E is given by,

$$\text{Volume of } E = \iiint_E dV$$

Finally, if the region E can be defined as the region under the function $z = f(x, y)$ and above the region D in xy -plane then,

$$\text{Volume of } E = \iint_D f(x, y) dA$$

Note as well that there are similar formulas for the other planes. For instance, the volume of the region behind the function $y = f(x, z)$ and in front of the region D in the xz -plane is given by,

$$\text{Volume of } E = \iint_D f(x, z) dA$$

Likewise, the the volume of the region behind the function $x = f(y, z)$ and in front of the region D in the yz -plane is given by,

$$\text{Volume of } E = \iint_D f(y, z) dA$$

Line Integrals

Introduction

In this section we are going to start looking at Calculus with vector fields (which we'll define in the first section). In particular we will be looking at a new type of integral, the line integral and some of the interpretations of the line integral. We will also take a look at one of the more important theorems involving line integrals, Green's Theorem.

Here is a listing of the topics covered in this chapter.

Vector Fields – In this section we introduce the concept of a vector field.

Line Integrals – Part I – Here we will start looking at line integrals. In particular we will look at line integrals with respect to arc length.

Line Integrals – Part II – We will continue looking at line integrals in this section. Here we will be looking at line integrals with respect to x , y , and/or z .

Line Integrals of Vector Fields – Here we will look at a third type of line integrals, line integrals of vector fields.

Fundamental Theorem for Line Integrals – In this section we will look at a version of the fundamental theorem of calculus for line integrals of vector fields.

Conservative Vector Fields – Here we will take a somewhat detailed look at conservative vector fields and how to find potential functions.

Green's Theorem – We will give Green's Theorem in this section as well as an interesting application of Green's Theorem.

Curl and Divergence – In this section we will introduce the concepts of the curl and the divergence of a vector field. We will also give two vector forms of Green's Theorem.

Vector Fields

We need to start this chapter off with the definition of a vector field as they will be a major component of both this chapter and the next. Let's start off with the formal definition of a vector field.

Definition

A vector field on two (or three) dimensional space is a function \vec{F} that assigns to each point (x, y) (or (x, y, z)) a two (or three dimensional) vector given by $\vec{F}(x, y)$ (or $\vec{F}(x, y, z)$).

That may not make a lot of sense, but most people do know what a vector field is, or at least they've seen a sketch of a vector field. If you've seen a current sketch giving the direction and magnitude of a flow of a fluid or the direction and magnitude of the winds then you've seen a sketch of a vector field.

The standard notation for the function \vec{F} is,

$$\vec{F}(x, y) = P(x, y)\vec{i} + Q(x, y)\vec{j}$$

$$\vec{F}(x, y, z) = P(x, y, z)\vec{i} + Q(x, y, z)\vec{j} + R(x, y, z)\vec{k}$$

depending on whether or not we're in two or three dimensions. The function P, Q, R (if it is present) are sometimes called **scalar functions**.

Let's take a quick look at a couple of examples.

Example 1 Sketch each of the following direction fields.

(a) $\vec{F}(x, y) = -y\vec{i} + x\vec{j}$ [\[Solution\]](#)

(b) $\vec{F}(x, y, z) = 2x\vec{i} - 2y\vec{j} - 2z\vec{k}$ [\[Solution\]](#)

Solution

(a) $\vec{F}(x, y) = -y\vec{i} + x\vec{j}$

Okay, to graph the vector field we need to get some "values" of the function. This means plugging in some points into the function. Here are a couple of evaluations.

$$\vec{F}\left(\frac{1}{2}, \frac{1}{2}\right) = -\frac{1}{2}\vec{i} + \frac{1}{2}\vec{j}$$

$$\vec{F}\left(\frac{1}{2}, -\frac{1}{2}\right) = -\left(-\frac{1}{2}\right)\vec{i} + \frac{1}{2}\vec{j} = \frac{1}{2}\vec{i} + \frac{1}{2}\vec{j}$$

$$\vec{F}\left(\frac{3}{2}, \frac{1}{4}\right) = -\frac{1}{4}\vec{i} + \frac{3}{2}\vec{j}$$

So, just what do these evaluations tell us? Well the first one tells us that at the point $\left(\frac{1}{2}, \frac{1}{2}\right)$ we will plot the vector $-\frac{1}{2}\vec{i} + \frac{1}{2}\vec{j}$. Likewise, the third evaluation tells us that at the point $\left(\frac{3}{2}, \frac{1}{4}\right)$ we will plot the vector $-\frac{1}{4}\vec{i} + \frac{3}{2}\vec{j}$.

We can continue in this fashion plotting vectors for several points and we'll get the following sketch of the vector field.

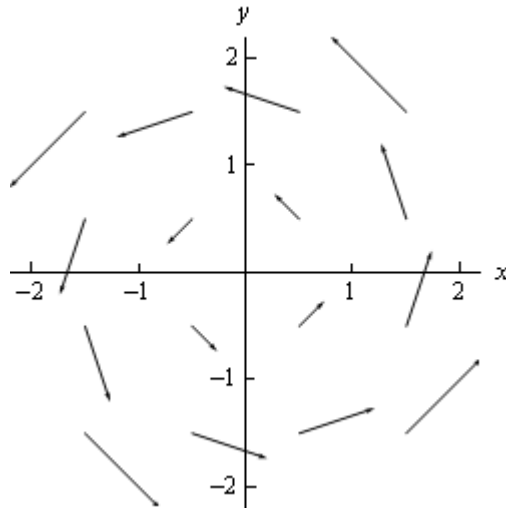

If we want significantly more points plotted then it is usually best to use a computer aided graphing system such as Maple or Mathematica. Here is a sketch with many more vectors included that was generated with Mathematica.

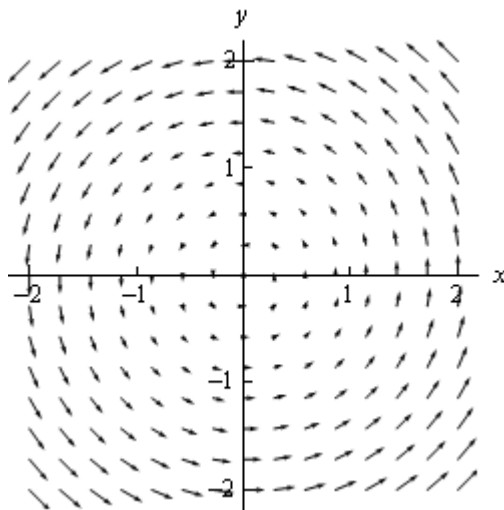

[\[Return to Problems\]](#)

(b) $\vec{F}(x, y, z) = 2x\vec{i} - 2y\vec{j} - 2z\vec{k}$

In the case of three dimensional vector fields it is almost always better to use Maple, Mathematica, or some other such tool. Despite that let's go ahead and do a couple of evaluations anyway.

$$\vec{F}(1, -3, 2) = 2\vec{i} + 6\vec{j} - 2\vec{k}$$

$$\vec{F}(0, 5, 3) = -10\vec{j}$$

Notice that z only affect the placement of the vector in this case and does not affect the direction

or the magnitude of the vector. Sometimes this will happen so don't get excited about it when it does.

Here is a couple of sketches generated by Mathematica. The sketch on the left is from the "front" and the sketch on the right is from "above".

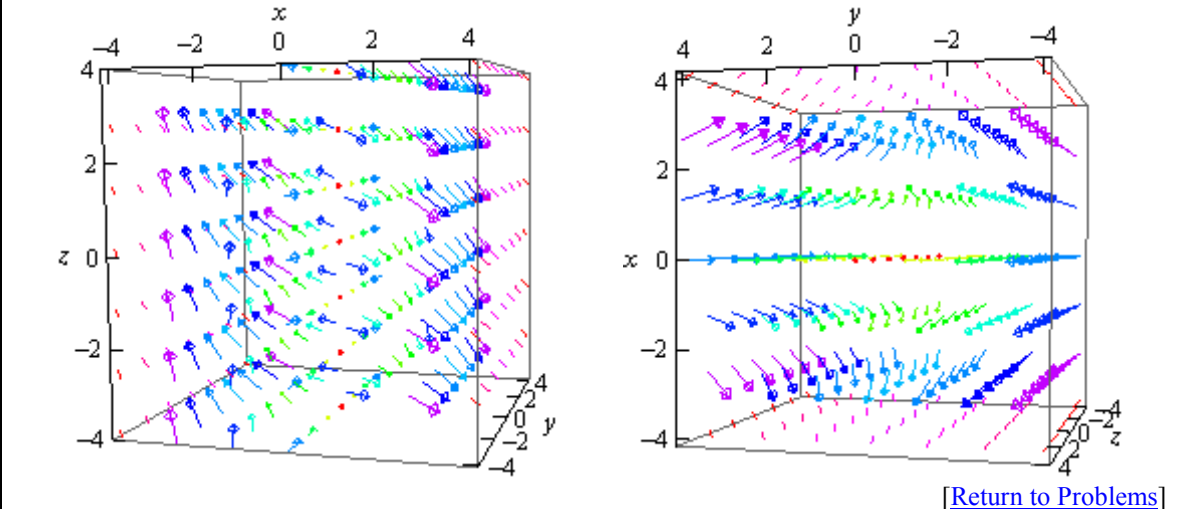

Now that we've seen a couple of vector fields let's notice that we've already seen a vector field function. In the second chapter we looked at the [gradient vector](#). Recall that given a function $f(x, y, z)$ the gradient vector is defined by,

$$\nabla f = \langle f_x, f_y, f_z \rangle$$

This is a vector field and is often called a **gradient vector field**.

In these cases the function $f(x, y, z)$ is often called a scalar function to differentiate it from the vector field.

Example 2 Find the gradient vector field of the following functions.

(a) $f(x, y) = x^2 \sin(5y)$

(b) $f(x, y, z) = ze^{-xy}$

Solution

(a) $f(x, y) = x^2 \sin(5y)$

Note that we only gave the gradient vector definition for a three dimensional function, but don't forget that there is also a two dimension definition. All that we need to drop off the third component of the vector.

Here is the gradient vector field for this function.

$$\nabla f = \langle 2x \sin(5y), 5x^2 \cos(5y) \rangle$$

$$(b) f(x, y, z) = ze^{-xy}$$

There isn't much to do here other than take the gradient.

$$\nabla f = \langle -yze^{-xy}, -xze^{-xy}, e^{-xy} \rangle$$

Let's do another example that will illustrate the relationship between the gradient vector field of a function and its contours.

Example 3 Sketch the gradient vector field for $f(x, y) = x^2 + y^2$ as well as several contours for this function.

Solution

Recall that the contours for a function are nothing more than curves defined by,

$$f(x, y) = k$$

for various values of k . So, for our function the contours are defined by the equation,

$$x^2 + y^2 = k$$

and so they are circles centered at the origin with radius \sqrt{k} .

Here is the gradient vector field for this function.

$$\nabla f(x, y) = 2x\vec{i} + 2y\vec{j}$$

Here is a sketch of several of the contours as well as the gradient vector field.

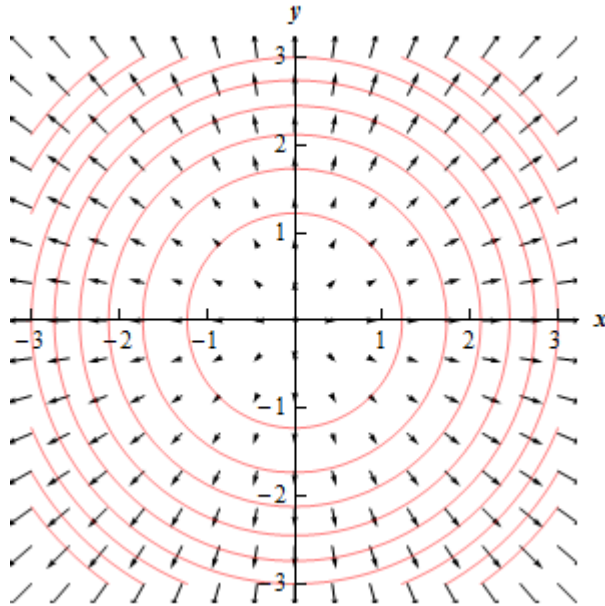

Notice that the vectors of the vector field are all perpendicular (or orthogonal) to the contours. This will always be the case when we are dealing with the contours of a function as well as its gradient vector field.

The k 's we used for the graph above were 1.5, 3, 4.5, 6, 7.5, 9, 10.5, 12, and 13.5. Now notice that as we increased k by 1.5 the contour curves get closer together and that as the contour curves get closer together the larger vectors become. In other words, the closer the contour curves are

(as k is increased by a fixed amount) the faster the function is changing at that point. Also [recall](#) that the direction of fastest change for a function is given by the gradient vector at that point. Therefore, it should make sense that the two ideas should match up as they do here.

The final topic of this section is that of conservative vector fields. A vector field \vec{F} is called a **conservative vector field** if there exists a function f such that $\vec{F} = \nabla f$. If \vec{F} is a conservative vector field then the function, f , is called a **potential function** for \vec{F} .

All this definition is saying is that a vector field is conservative if it is also a gradient vector field for some function.

For instance the vector field $\vec{F} = y\vec{i} + x\vec{j}$ is a conservative vector field with a potential function of $f(x, y) = xy$ because $\nabla f = \langle y, x \rangle$.

On the other hand, $\vec{F} = -y\vec{i} + x\vec{j}$ is not a conservative vector field since there is no function f such that $\vec{F} = \nabla f$. If you're not sure that you believe this at this point be patient, we will be able to prove this in a couple of [sections](#). In that section we will also show how to find the potential function for a conservative vector field.

Line Integrals – Part I

In this section we are now going to introduce a new kind of integral. However, before we do that it is important to note that you will need to remember how to parameterize equations, or put another way, you will need to be able to write down a set of parametric equations for a given curve. You should have seen some of this in your Calculus II course. If you need some review you should go back and [review](#) some of the basics of parametric equations and curves.

Here are some of the more basic curves that we'll need to know how to do as well as limits on the parameter if they are required.

| Curve | Parametric Equations | |
|---|---|---|
| | Counter-Clockwise | Clockwise |
| $\frac{x^2}{a^2} + \frac{y^2}{b^2} = 1$ (Ellipse) | $x = a \cos(t)$ $y = b \sin(t)$ $0 \leq t \leq 2\pi$ | $x = a \cos(t)$ $y = -b \sin(t)$ $0 \leq t \leq 2\pi$ |
| $x^2 + y^2 = r^2$ (Circle) | $x = r \cos(t)$ $y = r \sin(t)$ $0 \leq t \leq 2\pi$ | $x = r \cos(t)$ $y = -r \sin(t)$ $0 \leq t \leq 2\pi$ |
| $y = f(x)$ | | $x = t$ $y = f(t)$ |
| $x = g(y)$ | | $x = g(t)$ $y = t$ |
| Line Segment From (x_0, y_0, z_0) to (x_1, y_1, z_1) | $\vec{r}(t) = (1-t)\langle x_0, y_0, z_0 \rangle + t\langle x_1, y_1, z_1 \rangle, \quad 0 \leq t \leq 1$ or $x = (1-t)x_0 + tx_1$ $y = (1-t)y_0 + ty_1, \quad 0 \leq t \leq 1$ $z = (1-t)z_0 + tz_1$ | |

With the final one we gave both the vector form of the equation as well as the parametric form and if we need the two-dimensional version then we just drop the z components. In fact, we will be using the two-dimensional version of this in this section.

For the ellipse and the circle we've given two parameterizations, one tracing out the curve clockwise and the other counter-clockwise. As we'll eventually see the direction that the curve is traced out can, on occasion, change the answer. Also, both of these "start" on the positive x -axis at $t = 0$.

Now let's move on to line integrals. In Calculus I we integrated $f(x)$, a function of a single variable, over an interval $[a, b]$. In this case we were thinking of x as taking all the values in this interval starting at a and ending at b . With line integrals we will start with integrating the function $f(x, y)$, a function of two variables, and the values of x and y that we're going to use will be the points, (x, y) , that lie on a curve C . Note that this is different from the double integrals that we were working with in the previous chapter where the points came out of some two-dimensional region.

Let's start with the curve C that the points come from. We will assume that the curve is *smooth* (defined shortly) and is given by the parametric equations,

$$x = h(t) \quad y = g(t) \quad a \leq t \leq b$$

We will often want to write the parameterization of the curve as a vector function. In this case the curve is given by,

$$\vec{r}(t) = h(t)\vec{i} + g(t)\vec{j} \quad a \leq t \leq b$$

The curve is called **smooth** if $\vec{r}'(t)$ is continuous and $\vec{r}'(t) \neq 0$ for all t .

The **line integral** of $f(x, y)$ along C is denoted by,

$$\int_C f(x, y) ds$$

We use a ds here to acknowledge the fact that we are moving along the curve, C , instead of the x -axis (denoted by dx) or the y -axis (denoted by dy). Because of the ds this is sometimes called the **line integral of f with respect to arc length**.

We've seen the notation ds before. If you recall from Calculus II when we looked at the [arc length](#) of a curve given by parametric equations we found it to be,

$$L = \int_a^b ds, \quad \text{where} \quad ds = \sqrt{\left(\frac{dx}{dt}\right)^2 + \left(\frac{dy}{dt}\right)^2} dt$$

It is no coincidence that we use ds for both of these problems. The ds is the same for both the arc length integral and the notation for the line integral.

So, to compute a line integral we will convert everything over to the parametric equations. The line integral is then,

$$\int_C f(x, y) ds = \int_a^b f(h(t), g(t)) \sqrt{\left(\frac{dx}{dt}\right)^2 + \left(\frac{dy}{dt}\right)^2} dt$$

Don't forget to plug the parametric equations into the function as well.

If we use the vector form of the parameterization we can simplify the notation up somewhat by noticing that,

$$\sqrt{\left(\frac{dx}{dt}\right)^2 + \left(\frac{dy}{dt}\right)^2} = \|\vec{r}'(t)\|$$

where $\|\vec{r}'(t)\|$ is the [magnitude](#) or norm of $\vec{r}'(t)$. Using this notation the line integral becomes,

$$\int_C f(x, y) ds = \int_a^b f(h(t), g(t)) \|\vec{r}'(t)\| dt$$

Note that as long as the parameterization of the curve C is traced out exactly once as t increases from a to b the value of the line integral will be independent of the parameterization of the curve.

Let's take a look at an example of a line integral.

Example 1 Evaluate $\int_C xy^4 ds$ where C is the right half of the circle, $x^2 + y^2 = 16$ rotated in the counter clockwise direction.

Solution

We first need a parameterization of the circle. This is given by,

$$x = 4 \cos t \quad y = 4 \sin t$$

We now need a range of t 's that will give the right half of the circle. The following range of t 's will do this.

$$-\frac{\pi}{2} \leq t \leq \frac{\pi}{2}$$

Now, we need the derivatives of the parametric equations and let's compute ds .

$$\frac{dx}{dt} = -4 \sin t \quad \frac{dy}{dt} = 4 \cos t$$

$$ds = \sqrt{16 \sin^2 t + 16 \cos^2 t} dt = 4 dt$$

The line integral is then,

$$\begin{aligned} \int_C xy^4 ds &= \int_{-\pi/2}^{\pi/2} 4 \cos t (4 \sin t)^4 (4) dt \\ &= 4096 \int_{-\pi/2}^{\pi/2} \cos t \sin^4 t dt \\ &= \frac{4096}{5} \sin^5 t \Big|_{-\pi/2}^{\pi/2} \\ &= \frac{8192}{5} \end{aligned}$$

Next we need to talk about line integrals over **piecewise smooth curves**. A piecewise smooth curve is any curve that can be written as the union of a finite number of smooth curves, C_1, \dots, C_n

where the end point of C_i is the starting point of C_{i+1} . Below is an illustration of a piecewise smooth curve.

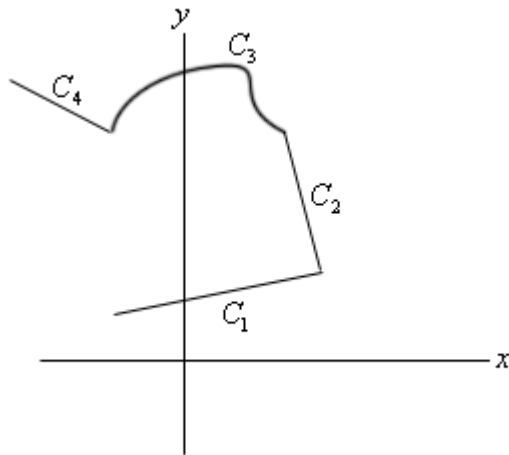

Evaluation of line integrals over piecewise smooth curves is a relatively simple thing to do. All we do is evaluate the line integral over each of the pieces and then add them up. The line integral for some function over the above piecewise curve would be,

$$\int_C f(x, y) ds = \int_{C_1} f(x, y) ds + \int_{C_2} f(x, y) ds + \int_{C_3} f(x, y) ds + \int_{C_4} f(x, y) ds$$

Let's see an example of this.

Example 2 Evaluate $\int_C 4x^3 ds$ where C is the curve shown below.

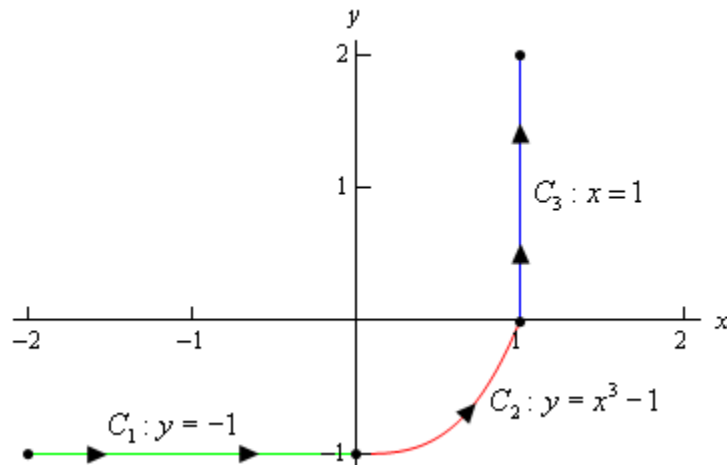

Solution

So, first we need to parameterize each of the curves.

$$C_1 : x = t, y = -1, \quad -2 \leq t \leq 0$$

$$C_2 : x = t, y = t^3 - 1, \quad 0 \leq t \leq 1$$

$$C_3 : x = 1, y = t, \quad 0 \leq t \leq 2$$

Now let's do the line integral over each of these curves.

$$\int_{C_1} 4x^3 ds = \int_{-2}^0 4t^3 \sqrt{(1)^2 + (0)^2} dt = \int_{-2}^0 4t^3 dt = t^4 \Big|_{-2}^0 = -16$$

$$\begin{aligned} \int_{C_2} 4x^3 ds &= \int_0^1 4t^3 \sqrt{(1)^2 + (3t^2)^2} dt \\ &= \int_0^1 4t^3 \sqrt{1 + 9t^4} dt \\ &= \frac{1}{9} \left(\frac{2}{3} \right) (1 + 9t^4)^{\frac{3}{2}} \Big|_0^1 = \frac{2}{27} \left(10^{\frac{3}{2}} - 1 \right) = 2.268 \end{aligned}$$

$$\int_{C_3} 4x^3 ds = \int_0^2 4(1)^3 \sqrt{(0)^2 + (1)^2} dt = \int_0^2 4 dt = 8$$

Finally, the line integral that we were asked to compute is,

$$\begin{aligned} \int_C 4x^3 ds &= \int_{C_1} 4x^3 ds + \int_{C_2} 4x^3 ds + \int_{C_3} 4x^3 ds \\ &= -16 + 2.268 + 8 \\ &= -5.732 \end{aligned}$$

Notice that we put direction arrows on the curve in the above example. The direction of motion along a curve *may* change the value of the line integral as we will see in the next section. Also note that the curve can be thought of a curve that takes us from the point $(-2, -1)$ to the point $(1, 2)$. Let's first see what happens to the line integral if we change the path between these two points.

Example 3 Evaluate $\int_C 4x^3 ds$ where C is the line segment from $(-2, -1)$ to $(1, 2)$.

Solution

From the parameterization formulas at the start of this section we know that the line segment starting at $(-2, -1)$ and ending at $(1, 2)$ is given by,

$$\begin{aligned} \vec{r}(t) &= (1-t)\langle -2, -1 \rangle + t\langle 1, 2 \rangle \\ &= \langle -2 + 3t, -1 + 3t \rangle \end{aligned}$$

for $0 \leq t \leq 1$. This means that the individual parametric equations are,

$$x = -2 + 3t \qquad y = -1 + 3t$$

Using this path the line integral is,

$$\begin{aligned}\int_C 4x^3 ds &= \int_0^1 4(-2+3t)^3 \sqrt{9+9} dt \\ &= 12\sqrt{2} \left(\frac{1}{12}\right) (-2+3t)^4 \Big|_0^1 \\ &= 12\sqrt{2} \left(-\frac{5}{4}\right) \\ &= -15\sqrt{2} = -21.213\end{aligned}$$

When doing these integrals don't forget simple Calc I substitutions to avoid having to do things like cubing out a term. Cubing it out is not that difficult, but it is more work than a simple substitution.

So, the previous two examples seem to suggest that if we change the path between two points then the value of the line integral (with respect to arc length) will change. While this will happen fairly regularly we can't assume that it will always happen. In a later section we will investigate this idea in more detail.

Next, let's see what happens if we change the direction of a path.

Example 4 Evaluate $\int_C 4x^3 ds$ where C is the line segment from $(1, 2)$ to $(-2, -1)$.

Solution

This one isn't much different, work wise, from the previous example. Here is the parameterization of the curve.

$$\begin{aligned}\vec{r}(t) &= (1-t)\langle 1, 2 \rangle + t\langle -2, -1 \rangle \\ &= \langle 1-3t, 2-3t \rangle\end{aligned}$$

for $0 \leq t \leq 1$. Remember that we are switching the direction of the curve and this will also change the parameterization so we can make sure that we start/end at the proper point.

Here is the line integral.

$$\begin{aligned}\int_C 4x^3 ds &= \int_0^1 4(1-3t)^3 \sqrt{9+9} dt \\ &= 12\sqrt{2} \left(-\frac{1}{12}\right) (1-3t)^4 \Big|_0^1 \\ &= 12\sqrt{2} \left(-\frac{5}{4}\right) \\ &= -15\sqrt{2} = -21.213\end{aligned}$$

So, it looks like when we switch the direction of the curve the line integral (with respect to arc length) will not change. This will always be true for these kinds of line integrals. However, there are other kinds of line integrals in which this won't be the case. We will see more examples of

this in the next couple of sections so don't get it into your head that changing the direction will never change the value of the line integral.

Before working another example let's formalize this idea up somewhat. Let's suppose that the curve C has the parameterization $x = h(t)$, $y = g(t)$. Let's also suppose that the initial point on the curve is A and the final point on the curve is B . The parameterization $x = h(t)$, $y = g(t)$ will then determine an **orientation** for the curve where the positive direction is the direction that is traced out as t increases. Finally, let $-C$ be the curve with the same points as C , however in this case the curve has B as the initial point and A as the final point, again t is increasing as we traverse this curve. In other words, given a curve C , the curve $-C$ is the same curve as C except the direction has been reversed.

We then have the following fact about line integrals with respect to arc length.

Fact

$$\int_C f(x, y) ds = \int_{-C} f(x, y) ds$$

So, for a line integral with respect to arc length we can change the direction of the curve and not change the value of the integral. This is a useful fact to remember as some line integrals will be easier in one direction than the other.

Now, let's work another example

Example 5 Evaluate $\int_C x ds$ for each of the following curves.

- (a) $C_1 : y = x^2$, $-1 \leq x \leq 1$ [\[Solution\]](#)
- (b) C_2 : The line segment from $(-1, 1)$ to $(1, 1)$. [\[Solution\]](#)
- (c) C_3 : The line segment from $(1, 1)$ to $(-1, 1)$. [\[Solution\]](#)

Solution

Before working any of these line integrals let's notice that all of these curves are paths that connect the points $(-1, 1)$ and $(1, 1)$. Also notice that $C_3 = -C_2$ and so by the fact above these two should give the same answer.

Here is a sketch of the three curves and note that the curves illustrating C_2 and C_3 have been separated a little to show that they are separate curves in some way even though they are the same line.

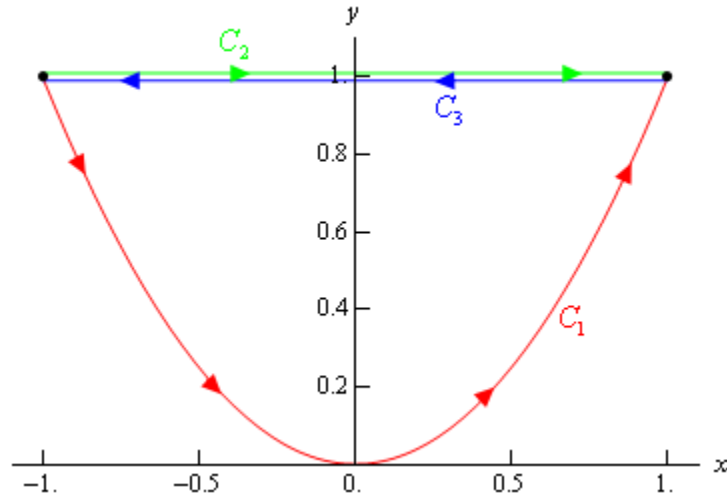

(a) $C_1 : y = x^2, -1 \leq x \leq 1$

Here is a parameterization for this curve.

$$C_1 : x = t, y = t^2, -1 \leq t \leq 1$$

Here is the line integral.

$$\int_{C_1} x \, ds = \int_{-1}^1 t \sqrt{1+4t^2} \, dt = \frac{1}{12} (1+4t^2)^{\frac{3}{2}} \Big|_{-1}^1 = 0$$

[\[Return to Problems\]](#)

(b) C_2 : The line segment from $(-1,1)$ to $(1,1)$.

There are two parameterizations that we could use here for this curve. The first is to use the formula we used in the previous couple of examples. That parameterization is,

$$\begin{aligned} C_2 : \vec{r}(t) &= (1-t)\langle -1, 1 \rangle + t\langle 1, 1 \rangle \\ &= \langle 2t-1, 1 \rangle \end{aligned}$$

for $0 \leq t \leq 1$.

Sometimes we have no choice but to use this parameterization. However, in this case there is a second (probably) easier parameterization. The second one uses the fact that we are really just graphing a portion of the line $y = 1$. Using this the parameterization is,

$$C_2 : x = t, y = 1, -1 \leq t \leq 1$$

This will be a much easier parameterization to use so we will use this. Here is the line integral for this curve.

$$\int_{C_2} x \, ds = \int_{-1}^1 t \sqrt{1+0} \, dt = \frac{1}{2} t^2 \Big|_{-1}^1 = 0$$

Note that this time, unlike the line integral we worked with in Examples 2, 3, and 4 we got the

same value for the integral despite the fact that the path is different. This will happen on occasion. We should also not expect this integral to be the same for all paths between these two points. At this point all we know is that for these two paths the line integral will have the same value. It is completely possible that there is another path between these two points that will give a different value for the line integral.

[\[Return to Problems\]](#)

(c) C_3 : The line segment from $(1,1)$ to $(-1,1)$.

Now, according to our fact above we really don't need to do anything here since we know that $C_3 = -C_2$. The fact tells us that this line integral should be the same as the second part (*i.e.* zero). However, let's verify that, plus there is a point we need to make here about the parameterization.

Here is the parameterization for this curve.

$$\begin{aligned} C_3 : \vec{r}(t) &= (1-t)\langle 1,1 \rangle + t\langle -1,1 \rangle \\ &= \langle 1-2t, 1 \rangle \end{aligned}$$

for $0 \leq t \leq 1$.

Note that this time we can't use the second parameterization that we used in part (b) since we need to move from right to left as the parameter increases and the second parameterization used in the previous part will move in the opposite direction.

Here is the line integral for this curve.

$$\int_{C_3} x \, ds = \int_0^1 (1-2t)\sqrt{4+0} \, dt = 2(t-t^2)\Big|_0^1 = 0$$

Sure enough we got the same answer as the second part.

[\[Return to Problems\]](#)

To this point in this section we've only looked at line integrals over a two-dimensional curve. However, there is no reason to restrict ourselves like that. We can do line integrals over three-dimensional curves as well.

Let's suppose that the three-dimensional curve C is given by the parameterization,

$$x = x(t), \quad y = y(t), \quad z = z(t) \quad a \leq t \leq b$$

then the line integral is given by,

$$\int_C f(x, y, z) \, ds = \int_a^b f(x(t), y(t), z(t)) \sqrt{\left(\frac{dx}{dt}\right)^2 + \left(\frac{dy}{dt}\right)^2 + \left(\frac{dz}{dt}\right)^2} \, dt$$

Note that often when dealing with three-dimensional space the parameterization will be given as a vector function.

$$\vec{r}(t) = \langle x(t), y(t), z(t) \rangle$$

Notice that we changed up the notation for the parameterization a little. Since we rarely use the function names we simply kept the x , y , and z and added on the (t) part to denote that they may be functions of the parameter.

Also notice that, as with two-dimensional curves, we have,

$$\sqrt{\left(\frac{dx}{dt}\right)^2 + \left(\frac{dy}{dt}\right)^2 + \left(\frac{dz}{dt}\right)^2} = \|\vec{r}'(t)\|$$

and the line integral can again be written as,

$$\int_C f(x, y, z) ds = \int_a^b f(x(t), y(t), z(t)) \|\vec{r}'(t)\| dt$$

So, outside of the addition of a third parametric equation line integrals in three-dimensional space work the same as those in two-dimensional space. Let's work a quick example.

Example 6 Evaluate $\int_C xyz ds$ where C is the helix given by, $\vec{r}(t) = \langle \cos(t), \sin(t), 3t \rangle$, $0 \leq t \leq 4\pi$.

Solution

Note that we first saw the vector equation for a helix back in the [Vector Functions](#) section. Here is a quick sketch of the helix.

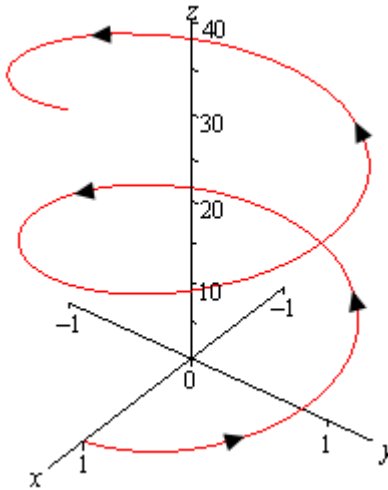

Here is the line integral.

$$\begin{aligned}
 \int_C xyz \, ds &= \int_0^{4\pi} 3t \cos(t) \sin(t) \sqrt{\sin^2 t + \cos^2 t + 9} \, dt \\
 &= \int_0^{4\pi} 3t \left(\frac{1}{2} \sin(2t) \right) \sqrt{1+9} \, dt \\
 &= \frac{3\sqrt{10}}{2} \int_0^{4\pi} t \sin(2t) \, dt \\
 &= \frac{3\sqrt{10}}{2} \left(\frac{1}{4} \sin(2t) - \frac{t}{2} \cos(2t) \right) \Big|_0^{4\pi} \\
 &= -3\sqrt{10} \pi
 \end{aligned}$$

You were able to do that integral right? It required [integration by parts](#).

So, as we can see there really isn't too much difference between two- and three-dimensional line integrals.

Line Integrals – Part II

In the previous section we looked at line integrals with respect to arc length. In this section we want to look at line integrals with respect to x and/or y .

As with the last section we will start with a two-dimensional curve C with parameterization,

$$x = x(t) \quad y = y(t) \quad a \leq t \leq b$$

The **line integral of f with respect to x** is,

$$\int_C f(x, y) dx = \int_a^b f(x(t), y(t)) x'(t) dt$$

The **line integral of f with respect to y** is,

$$\int_C f(x, y) dy = \int_a^b f(x(t), y(t)) y'(t) dt$$

Note that the only notational difference between these two and the line integral with respect to arc length (from the previous section) is the differential. These have a dx or dy while the line integral with respect to arc length has a ds . So when evaluating line integrals be careful to first note which differential you've got so you don't work the wrong kind of line integral.

These two integrals often appear together and so we have the following shorthand notation for these cases.

$$\int_C P dx + Q dy = \int_C P(x, y) dx + \int_C Q(x, y) dy$$

Let's take a quick look at an example of this kind of line integral.

Example 1 Evaluate $\int_C \sin(\pi y) dy + yx^2 dx$ where C is the line segment from $(0, 2)$ to $(1, 4)$.

Solution

Here is the parameterization of the curve.

$$\vec{r}(t) = (1-t)\langle 0, 2 \rangle + t\langle 1, 4 \rangle = \langle t, 2+2t \rangle \quad 0 \leq t \leq 1$$

The line integral is,

$$\begin{aligned} \int_C \sin(\pi y) dy + yx^2 dx &= \int_C \sin(\pi y) dy + \int_C yx^2 dx \\ &= \int_0^1 \sin(\pi(2+2t))(2) dt + \int_0^1 (2+2t)(t)^2 (1) dt \\ &= -\frac{1}{\pi} \cos(2\pi + 2\pi t) \Big|_0^1 + \left(\frac{2}{3} t^3 + \frac{1}{2} t^4 \right) \Big|_0^1 \\ &= \frac{7}{6} \end{aligned}$$

In the previous section we saw that changing the direction of the curve for a line integral with respect to arc length doesn't change the value of the integral. Let's see what happens with line integrals with respect to x and/or y .

Example 2 Evaluate $\int_C \sin(\pi y) dy + yx^2 dx$ where C is the line segment from $(1, 4)$ to $(0, 2)$.

Solution

So, we simply changed the direction of the curve. Here is the new parameterization.

$$\vec{r}(t) = (1-t)\langle 1, 4 \rangle + t\langle 0, 2 \rangle = \langle 1-t, 4-2t \rangle \quad 0 \leq t \leq 1$$

The line integral in this case is,

$$\begin{aligned} \int_C \sin(\pi y) dy + yx^2 dx &= \int_C \sin(\pi y) dy + \int_C yx^2 dx \\ &= \int_0^1 \sin(\pi(4-2t))(-2) dt + \int_0^1 (4-2t)(1-t)^2 (-1) dt \\ &= -\frac{1}{\pi} \cos(4\pi - 2\pi t) \Big|_0^1 - \left(-\frac{1}{2}t^4 + \frac{8}{3}t^3 - 5t^2 + 4t \right) \Big|_0^1 \\ &= -\frac{7}{6} \end{aligned}$$

So, switching the direction of the curve got us a different value or at least the opposite sign of the value from the first example. In fact this will always happen with these kinds of line integrals.

Fact

If C is any curve then,

$$\int_{-C} f(x, y) dx = -\int_C f(x, y) dx \quad \text{and} \quad \int_{-C} f(x, y) dy = -\int_C f(x, y) dy$$

With the combined form of these two integrals we get,

$$\int_{-C} Pdx + Q dy = -\int_C Pdx + Q dy$$

We can also do these integrals over three-dimensional curves as well. In this case we will pick up a third integral (with respect to z) and the three integrals will be.

$$\int_C f(x, y, z) dx = \int_a^b f(x(t), y(t), z(t)) x'(t) dt$$

$$\int_C f(x, y, z) dy = \int_a^b f(x(t), y(t), z(t)) y'(t) dt$$

$$\int_C f(x, y, z) dz = \int_a^b f(x(t), y(t), z(t)) z'(t) dt$$

where the curve C is parameterized by

$$x = x(t) \quad y = y(t) \quad z = z(t) \quad a \leq t \leq b$$

As with the two-dimensional version these three will often occur together so the shorthand we'll be using here is,

$$\int_C P dx + Q dy + R dz = \int_C P(x, y, z) dx + \int_C Q(x, y, z) dy + \int_C R(x, y, z) dz$$

Let's work an example.

Example 3 Evaluate $\int_C y dx + x dy + z dz$ where C is given by $x = \cos t$, $y = \sin t$, $z = t^2$,

$$0 \leq t \leq 2\pi.$$

Solution

So, we already have the curve parameterized so there really isn't much to do other than evaluate the integral.

$$\begin{aligned} \int_C y dx + x dy + z dz &= \int_C y dx + \int_C x dy + \int_C z dz \\ &= \int_0^{2\pi} \sin t (-\sin t) dt + \int_0^{2\pi} \cos t (\cos t) dt + \int_0^{2\pi} t^2 (2t) dt \\ &= -\int_0^{2\pi} \sin^2 t dt + \int_0^{2\pi} \cos^2 t dt + \int_0^{2\pi} 2t^3 dt \\ &= -\frac{1}{2} \int_0^{2\pi} (1 - \cos(2t)) dt + \frac{1}{2} \int_0^{2\pi} (1 + \cos(2t)) dt + \int_0^{2\pi} 2t^3 dt \\ &= \left(-\frac{1}{2} \left(t - \frac{1}{2} \sin(2t) \right) + \frac{1}{2} \left(t + \frac{1}{2} \sin(2t) \right) + \frac{1}{2} t^4 \right) \Bigg|_0^{2\pi} \\ &= 8\pi^4 \end{aligned}$$

Line Integrals of Vector Fields

In the previous two sections we looked at line integrals of functions. In this section we are going to evaluate line integrals of vector fields. We'll start with the vector field,

$$\vec{F}(x, y, z) = P(x, y, z)\vec{i} + Q(x, y, z)\vec{j} + R(x, y, z)\vec{k}$$

and the three-dimensional, smooth curve given by

$$\vec{r}(t) = x(t)\vec{i} + y(t)\vec{j} + z(t)\vec{k} \quad a \leq t \leq b$$

The **line integral of \vec{F} along C** is

$$\int_C \vec{F} \cdot d\vec{r} = \int_a^b \vec{F}(\vec{r}(t)) \cdot \vec{r}'(t) dt$$

Note the notation in the left side. That really is a [dot product](#) of the vector field and the differential really is a vector. Also, $\vec{F}(\vec{r}(t))$ is a shorthand for,

$$\vec{F}(\vec{r}(t)) = \vec{F}(x(t), y(t), z(t))$$

We can also write line integrals of vector fields as a line integral with respect to arc length as follows,

$$\int_C \vec{F} \cdot d\vec{r} = \int_C \vec{F} \cdot \vec{T} ds$$

where $\vec{T}(t)$ is the unit tangent vector and is given by,

$$\vec{T}(t) = \frac{\vec{r}'(t)}{\|\vec{r}'(t)\|}$$

If we use our knowledge on how to compute line integrals with respect to arc length we can see that this second form is equivalent to the first form given above.

$$\begin{aligned} \int_C \vec{F} \cdot d\vec{r} &= \int_C \vec{F} \cdot \vec{T} ds \\ &= \int_a^b \vec{F}(\vec{r}(t)) \cdot \frac{\vec{r}'(t)}{\|\vec{r}'(t)\|} \|\vec{r}'(t)\| dt \\ &= \int_a^b \vec{F}(\vec{r}(t)) \cdot \vec{r}'(t) dt \end{aligned}$$

In general we use the first form to compute these line integral as it is usually much easier to use. Let's take a look at a couple of examples.

Example 1 Evaluate $\int_C \vec{F} \cdot d\vec{r}$ where $\vec{F}(x, y, z) = 8x^2yz\vec{i} + 5z\vec{j} - 4xy\vec{k}$ and C is the curve given by $\vec{r}(t) = t\vec{i} + t^2\vec{j} + t^3\vec{k}$, $0 \leq t \leq 1$.

Solution

Okay, we first need the vector field evaluated along the curve.

$$\vec{F}(\vec{r}(t)) = 8t^2(t^2)(t^3)\vec{i} + 5t^3\vec{j} - 4t(t^2)\vec{k} = 8t^7\vec{i} + 5t^3\vec{j} - 4t^3\vec{k}$$

Next we need the derivative of the parameterization.

$$\vec{r}'(t) = \vec{i} + 2t\vec{j} + 3t^2\vec{k}$$

Finally, let's get the dot product taken care of.

$$\vec{F}(\vec{r}(t)) \cdot \vec{r}'(t) = 8t^7 + 10t^4 - 12t^5$$

The line integral is then,

$$\begin{aligned} \int_C \vec{F} \cdot d\vec{r} &= \int_0^1 (8t^7 + 10t^4 - 12t^5) dt \\ &= \left(t^8 + 2t^5 - 2t^6 \right) \Big|_0^1 \\ &= 1 \end{aligned}$$

Example 2 Evaluate $\int_C \vec{F} \cdot d\vec{r}$ where $\vec{F}(x, y, z) = xz\vec{i} - yz\vec{k}$ and C is the line segment from $(-1, 2, 0)$ and $(3, 0, 1)$.

Solution

We'll first need the parameterization of the line segment. We saw how to get the parameterization of line segments in the first [section](#) on line integrals. We've been using the two dimensional version of this over the last couple of sections. Here is the parameterization for the line.

$$\begin{aligned} \vec{r}(t) &= (1-t)\langle -1, 2, 0 \rangle + t\langle 3, 0, 1 \rangle \\ &= \langle 4t - 1, 2 - 2t, t \rangle, \quad 0 \leq t \leq 1 \end{aligned}$$

So, let's get the vector field evaluated along the curve.

$$\begin{aligned} \vec{F}(\vec{r}(t)) &= (4t - 1)(t)\vec{i} - (2 - 2t)(t)\vec{k} \\ &= (4t^2 - t)\vec{i} - (2t - 2t^2)\vec{k} \end{aligned}$$

Now we need the derivative of the parameterization.

$$\vec{r}'(t) = \langle 4, -2, 1 \rangle$$

The dot product is then,

$$\vec{F}(\vec{r}(t)) \cdot \vec{r}'(t) = 4(4t^2 - t) - (2t - 2t^2) = 18t^2 - 6t$$

The line integral becomes,

$$\begin{aligned} \int_C \vec{F} \cdot d\vec{r} &= \int_0^1 18t^2 - 6t \, dt \\ &= (6t^3 - 3t^2) \Big|_0^1 \\ &= 3 \end{aligned}$$

Let's close this section out by doing one of these in general to get a nice relationship between line integrals of vector fields and line integrals with respect to x , y , and z .

Given the vector field $\vec{F}(x, y, z) = P\vec{i} + Q\vec{j} + R\vec{k}$ and the curve C parameterized by $\vec{r}(t) = x(t)\vec{i} + y(t)\vec{j} + z(t)\vec{k}$, $a \leq t \leq b$ the line integral is,

$$\begin{aligned} \int_C \vec{F} \cdot d\vec{r} &= \int_a^b (P\vec{i} + Q\vec{j} + R\vec{k}) \cdot (x'\vec{i} + y'\vec{j} + z'\vec{k}) \, dt \\ &= \int_a^b Px' + Qy' + Rz' \, dt \\ &= \int_a^b Px' \, dt + \int_a^b Qy' \, dt + \int_a^b Rz' \, dt \\ &= \int_C P \, dx + \int_C Q \, dy + \int_C R \, dz \\ &= \int_C P \, dx + Q \, dy + R \, dz \end{aligned}$$

So, we see that,

$$\int_C \vec{F} \cdot d\vec{r} = \int_C P \, dx + Q \, dy + R \, dz$$

Note that this gives us another method for evaluating line integrals of vector fields.

This also allows us to say the following about reversing the direction of the path with line integrals of vector fields.

Fact

$$\int_{-C} \vec{F} \cdot d\vec{r} = - \int_C \vec{F} \cdot d\vec{r}$$

This should make some sense given that we know that this is true for line integrals with respect to x , y , and/or z and that line integrals of vector fields can be defined in terms of line integrals with respect to x , y , and z .

Fundamental Theorem for Line Integrals

In Calculus I we had the [Fundamental Theorem of Calculus](#) that told us how to evaluate definite integrals. This told us,

$$\int_a^b F'(x) dx = F(b) - F(a)$$

It turns out that there is a version of this for line integrals over certain kinds of vector fields. Here it is.

Theorem

Suppose that C is a [smooth](#) curve given by $\vec{r}(t)$, $a \leq t \leq b$. Also suppose that f is a function whose gradient vector, ∇f , is continuous on C . Then,

$$\int_C \nabla f \cdot d\vec{r} = f(\vec{r}(b)) - f(\vec{r}(a))$$

Note that $\vec{r}(a)$ represents the initial point on C while $\vec{r}(b)$ represents the final point on C .

Also, we did not specify the number of variables for the function since it is really immaterial to the theorem. The theorem will hold regardless of the number of variables in the function.

Proof

This is a fairly straight forward proof.

For the purposes of the proof we'll assume that we're working in three dimensions, but it can be done in any dimension.

Let's start by just computing the line integral.

$$\begin{aligned} \int_C \nabla f \cdot d\vec{r} &= \int_a^b \nabla f(\vec{r}(t)) \cdot \vec{r}'(t) dt \\ &= \int_a^b \left(\frac{\partial f}{\partial x} \frac{dx}{dt} + \frac{\partial f}{\partial y} \frac{dy}{dt} + \frac{\partial f}{\partial z} \frac{dz}{dt} \right) dt \end{aligned}$$

Now, at this point we can use the [Chain Rule](#) to simplify the integrand as follows,

$$\begin{aligned} \int_C \nabla f \cdot d\vec{r} &= \int_a^b \left(\frac{\partial f}{\partial x} \frac{dx}{dt} + \frac{\partial f}{\partial y} \frac{dy}{dt} + \frac{\partial f}{\partial z} \frac{dz}{dt} \right) dt \\ &= \int_a^b \frac{d}{dt} [f(\vec{r}(t))] dt \end{aligned}$$

To finish this off we just need to use the Fundamental Theorem of Calculus for single integrals.

$$\int_C \nabla f \cdot d\vec{r} = f(\vec{r}(b)) - f(\vec{r}(a))$$

■

Let's take a quick look at an example of using this theorem.

Example 1 Evaluate $\int_C \nabla f \cdot d\vec{r}$ where $f(x, y, z) = \cos(\pi x) + \sin(\pi y) - xyz$ and C is any path that starts at $(1, \frac{1}{2}, 2)$ and ends at $(2, 1, -1)$.

Solution

First let's notice that we didn't specify the path for getting from the first point to the second point. The reason for this is simple. The theorem above tells us that all we need are the initial and final points on the curve in order to evaluate this kind of line integral.

So, let $\vec{r}(t)$, $a \leq t \leq b$ be any path that starts at $(1, \frac{1}{2}, 2)$ and ends at $(2, 1, -1)$. Then,

$$\vec{r}(a) = \left\langle 1, \frac{1}{2}, 2 \right\rangle \quad \vec{r}(b) = \langle 2, 1, -1 \rangle$$

The integral is then,

$$\begin{aligned} \int_C \nabla f \cdot d\vec{r} &= f(2, 1, -1) - f\left(1, \frac{1}{2}, 2\right) \\ &= \cos(2\pi) + \sin \pi - 2(1)(-1) - \left(\cos \pi + \sin\left(\frac{\pi}{2}\right) - 1\left(\frac{1}{2}\right)(2) \right) \\ &= 4 \end{aligned}$$

Notice that we also didn't need the gradient vector to actually do this line integral. However, for the practice of finding gradient vectors here it is,

$$\nabla f = \langle -\pi \sin(\pi x) - yz, \pi \cos(\pi y) - xz, -xy \rangle$$

The most important idea to get from this example is not how to do the integral as that's pretty simple, all we do is plug the final point and initial point into the function and subtract the two results. The important idea from this example (and hence about the Fundamental Theorem of Calculus) is that, for these kinds of line integrals, we didn't really need to know the path to get the answer. In other words, we could use any path we want and we'll always get the same results.

In the first section on line integrals (even though we weren't looking at vector fields) we saw that often when we change the path we will change the value of the line integral. We now have a type of line integral for which we know that changing the path will NOT change the value of the line integral.

Let's formalize this idea up a little. Here are some definitions. The first one we've already seen before, but it's been a while and it's important in this section so we'll give it again. The remaining definitions are new.

Definitions

First suppose that \vec{F} is a continuous vector field in some domain D .

1. \vec{F} is a **conservative** vector field if there is a function f such that $\vec{F} = \nabla f$. The function f is called a **potential function** for the vector field. We first saw this definition in the first section of this chapter.

2. $\int_C \vec{F} \cdot d\vec{r}$ is **independent of path** if $\int_{C_1} \vec{F} \cdot d\vec{r} = \int_{C_2} \vec{F} \cdot d\vec{r}$ for any two paths C_1 and C_2 in D with the same initial and final points.
3. A path C is called **closed** if its initial and final points are the same point. For example a circle is a closed path.
4. A path C is **simple** if it doesn't cross itself. A circle is a simple curve while a figure 8 type curve is not simple.
5. A region D is **open** if it doesn't contain any of its boundary points.
6. A region D is **connected** if we can connect any two points in the region with a path that lies completely in D .
7. A region D is **simply-connected** if it is connected and it contains no holes. We won't need this one until the next section, but it fits in with all the other definitions given here so this was a natural place to put the definition.

With these definitions we can now give some nice facts.

Facts

1. $\int_C \nabla f \cdot d\vec{r}$ is independent of path.

This is easy enough to prove since all we need to do is look at the theorem above. The theorem tells us that in order to evaluate this integral all we need are the initial and final points of the curve. This in turn tells us that the line integral must be independent of path.

2. If \vec{F} is a conservative vector field then $\int_C \vec{F} \cdot d\vec{r}$ is independent of path.

This fact is also easy enough to prove. If \vec{F} is conservative then it has a potential function, f , and so the line integral becomes $\int_C \vec{F} \cdot d\vec{r} = \int_C \nabla f \cdot d\vec{r}$. Then using the first fact we know that this line integral must be independent of path.

3. If \vec{F} is a continuous vector field on an open connected region D and if $\int_C \vec{F} \cdot d\vec{r}$ is independent of path (for any path in D) then \vec{F} is a conservative vector field on D .

4. If $\int_C \vec{F} \cdot d\vec{r}$ is independent of path then $\int_C \vec{F} \cdot d\vec{r} = 0$ for every closed path C .

5. If $\int_C \vec{F} \cdot d\vec{r} = 0$ for every closed path C then $\int_C \vec{F} \cdot d\vec{r}$ is independent of path.

These are some nice facts to remember as we work with line integrals over vector fields. Also notice that 2 & 3 and 4 & 5 are converses of each other.

Conservative Vector Fields

In the previous section we saw that if we knew that the vector field \vec{F} was conservative then $\int_C \vec{F} \cdot d\vec{r}$ was independent of path. This in turn means that we can easily evaluate this line integral provided we can find a potential function for \vec{F} .

In this section we want to look at two questions. First, given a vector field \vec{F} is there any way of determining if it is a conservative vector field? Secondly, if we know that \vec{F} is a conservative vector field how do we go about finding a potential function for the vector field?

The first question is easy to answer at this point if we have a two-dimensional vector field. For higher dimensional vector fields we'll need to wait until the final section in this chapter to answer this question. With that being said let's see how we do it for two-dimensional vector fields.

Theorem

Let $\vec{F} = P\vec{i} + Q\vec{j}$ be a vector field on an [open](#) and [simply-connected](#) region D . Then if P and Q have continuous first order partial derivatives in D and

$$\frac{\partial P}{\partial y} = \frac{\partial Q}{\partial x}$$

the vector field \vec{F} is conservative.

Let's take a look at a couple of examples.

Example 1 Determine if the following vector fields are conservative or not.

(a) $\vec{F}(x, y) = (x^2 - yx)\vec{i} + (y^2 - xy)\vec{j}$ [[Solution](#)]

(b) $\vec{F}(x, y) = (2xe^{xy} + x^2ye^{xy})\vec{i} + (x^3e^{xy} + 2y)\vec{j}$ [[Solution](#)]

Solution

Okay, there really isn't too much to these. All we do is identify P and Q then take a couple of derivatives and compare the results.

(a) $\vec{F}(x, y) = (x^2 - yx)\vec{i} + (y^2 - xy)\vec{j}$

In this case here is P and Q and the appropriate partial derivatives.

$$P = x^2 - yx \qquad \frac{\partial P}{\partial y} = -x$$

$$Q = y^2 - xy \qquad \frac{\partial Q}{\partial x} = -y$$

So, since the two partial derivatives are not the same this vector field is NOT conservative.

[\[Return to Problems\]](#)

$$(b) \vec{F}(x, y) = (2xe^{xy} + x^2ye^{xy})\vec{i} + (x^3e^{xy} + 2y)\vec{j}$$

Here is P and Q as well as the appropriate derivatives.

$$P = 2xe^{xy} + x^2ye^{xy} \qquad \frac{\partial P}{\partial y} = 2x^2e^{xy} + x^2e^{xy} + x^3ye^{xy} = 3x^2e^{xy} + x^3ye^{xy}$$

$$Q = x^3e^{xy} + 2y \qquad \frac{\partial Q}{\partial x} = 3x^2e^{xy} + x^3ye^{xy}$$

The two partial derivatives are equal and so this is a conservative vector field.

[\[Return to Problems\]](#)

Now that we know how to identify if a two-dimensional vector field is conservative we need to address how to find a potential function for the vector field. This is actually a fairly simple process. First, let's assume that the vector field is conservative and so we know that a potential function, $f(x, y)$ exists. We can then say that,

$$\nabla f = \frac{\partial f}{\partial x}\vec{i} + \frac{\partial f}{\partial y}\vec{j} = P\vec{i} + Q\vec{j} = \vec{F}$$

Or by setting components equal we have,

$$\frac{\partial f}{\partial x} = P \qquad \text{and} \qquad \frac{\partial f}{\partial y} = Q$$

By integrating each of these with respect to the appropriate variable we can arrive at the following two equations.

$$f(x, y) = \int P(x, y) dx \qquad \text{or} \qquad f(x, y) = \int Q(x, y) dy$$

We saw this kind of integral briefly at the end of the section on [iterated integrals](#) in the previous chapter.

It is usually best to see how we use these two facts to find a potential function in an example or two.

Example 2 Determine if the following vector fields are conservative and find a potential function for the vector field if it is conservative.

(a) $\vec{F} = (2x^3y^4 + x)\vec{i} + (2x^4y^3 + y)\vec{j}$ [Solution]

(b) $\vec{F}(x, y) = (2xe^{xy} + x^2ye^{xy})\vec{i} + (x^3e^{xy} + 2y)\vec{j}$ [Solution]

Solution

(a) $\vec{F} = (2x^3y^4 + x)\vec{i} + (2x^4y^3 + y)\vec{j}$

Let's first identify P and Q and then check that the vector field is conservative..

$$P = 2x^3y^4 + x \quad \frac{\partial P}{\partial y} = 8x^3y^3$$

$$Q = 2x^4y^3 + y \quad \frac{\partial Q}{\partial x} = 8x^3y^3$$

So, the vector field is conservative. Now let's find the potential function. From the first fact above we know that,

$$\frac{\partial f}{\partial x} = 2x^3y^4 + x \quad \frac{\partial f}{\partial y} = 2x^4y^3 + y$$

From these we can see that

$$f(x, y) = \int 2x^3y^4 + x dx \quad \text{or} \quad f(x, y) = \int 2x^4y^3 + y dy$$

We can use either of these to get the process started. **Recall** that we are going to have to be careful with the "constant of integration" which ever integral we choose to use. For this example let's work with the first integral and so that means that we are asking what function did we differentiate with respect to x to get the integrand. This means that the "constant of integration" is going to have to be a function of y since any function consisting only of y and/or constants will differentiate to zero when taking the partial derivative with respect to x .

Here is the first integral.

$$f(x, y) = \int 2x^3y^4 + x dx$$

$$= \frac{1}{2}x^4y^4 + \frac{1}{2}x^2 + h(y)$$

where $h(y)$ is the "constant of integration".

We now need to determine $h(y)$. This is easier than it might at first appear to be. To get to this point we've used the fact that we knew P , but we will also need to use the fact that we know Q to complete the problem. Recall that Q is really the derivative of f with respect to y . So, if we differentiate our function with respect to y we know what it should be.

So, let's differentiate f (including the $h(y)$) with respect to y and set it equal to Q since that is what the derivative is supposed to be.

$$\frac{\partial f}{\partial y} = 2x^4y^3 + h'(y) = 2x^4y^3 + y = Q$$

From this we can see that,

$$h'(y) = y$$

Notice that since $h'(y)$ is a function only of y so if there are any x 's in the equation at this point we will know that we've made a mistake. At this point finding $h(y)$ is simple.

$$h(y) = \int h'(y) dy = \int y dy = \frac{1}{2}y^2 + c$$

So, putting this all together we can see that a potential function for the vector field is,

$$f(x, y) = \frac{1}{2}x^4y^4 + \frac{1}{2}x^2 + \frac{1}{2}y^2 + c$$

Note that we can always check our work by verifying that $\nabla f = \vec{F}$. Also note that because the c can be anything there are an infinite number of possible potential functions, although they will only vary by an additive constant.

[\[Return to Problems\]](#)

$$(b) \vec{F}(x, y) = (2xe^{xy} + x^2ye^{xy})\vec{i} + (x^3e^{xy} + 2y)\vec{j}$$

Okay, this one will go a lot faster since we don't need to go through as much explanation. We've already verified that this vector field is conservative in the first set of examples so we won't bother redoing that.

Let's start with the following,

$$\frac{\partial f}{\partial x} = 2xe^{xy} + x^2ye^{xy} \qquad \frac{\partial f}{\partial y} = x^3e^{xy} + 2y$$

This means that we can do either of the following integrals,

$$f(x, y) = \int 2xe^{xy} + x^2ye^{xy} dx \qquad \text{or} \qquad f(x, y) = \int x^3e^{xy} + 2y dy$$

While we can do either of these the first integral would be somewhat unpleasant as we would need to do integration by parts on each portion. On the other hand the second integral is fairly simple since the second term only involves y 's and the first term can be done with the substitution $u = xy$. So, from the second integral we get,

$$f(x, y) = x^2e^{xy} + y^2 + h(x)$$

Notice that this time the "constant of integration" will be a function of x . If we differentiate this with respect to x and set equal to P we get,

$$\frac{\partial f}{\partial x} = 2xe^{xy} + x^2ye^{xy} + h'(x) = 2xe^{xy} + x^2ye^{xy} = P$$

So, in this case it looks like,

$$h'(x) = 0 \quad \Rightarrow \quad h(x) = c$$

So, in this case the “constant of integration” really was a constant. Sometimes this will happen and sometimes it won't.

Here is the potential function for this vector field.

$$f(x, y) = x^2 e^{xy} + y^2 + c$$

[\[Return to Problems\]](#)

Now, as noted above we don't have a way (yet) of determining if a three-dimensional vector field is conservative or not. However, if we are given that a three-dimensional vector field is conservative finding a potential function is similar to the above process, although the work will be a little more involved.

In this case we will use the fact that,

$$\nabla f = \frac{\partial f}{\partial x} \vec{i} + \frac{\partial f}{\partial y} \vec{j} + \frac{\partial f}{\partial z} \vec{k} = P \vec{i} + Q \vec{j} + R \vec{k} = \vec{F}$$

Let's take a quick look at an example.

Example 3 Find a potential function for the vector field,

$$\vec{F} = 2xy^3z^4 \vec{i} + 3x^2y^2z^4 \vec{j} + 4x^2y^3z^3 \vec{k}$$

Solution

Okay, we'll start off with the following equalities.

$$\frac{\partial f}{\partial x} = 2xy^3z^4 \quad \frac{\partial f}{\partial y} = 3x^2y^2z^4 \quad \frac{\partial f}{\partial z} = 4x^2y^3z^3$$

To get started we can integrate the first one with respect to x , the second one with respect to y , or the third one with respect to z . Let's integrate the first one with respect to x .

$$f(x, y, z) = \int 2xy^3z^4 dx = x^2y^3z^4 + g(y, z)$$

Note that this time the “constant of integration” will be a function of both y and z since differentiating anything of that form with respect to x will differentiate to zero.

Now, we can differentiate this with respect to y and set it equal to Q . Doing this gives,

$$\frac{\partial f}{\partial y} = 3x^2y^2z^4 + g_y(y, z) = 3x^2y^2z^4 = Q$$

Of course we'll need to take the partial derivative of the constant of integration since it is a function of two variables. It looks like we've now got the following,

$$g_y(y, z) = 0 \quad \Rightarrow \quad g(y, z) = h(z)$$

Since differentiating $g(y, z)$ with respect to y gives zero then $g(y, z)$ could at most be a function of z . This means that we now know the potential function must be in the following form.

$$f(x, y, z) = x^2 y^3 z^4 + h(z)$$

To finish this out all we need to do is differentiate with respect to z and set the result equal to R .

$$\frac{\partial f}{\partial z} = 4x^2 y^3 z^3 + h'(z) = 4x^2 y^3 z^3 = R$$

So,

$$h'(z) = 0 \quad \Rightarrow \quad h(z) = c$$

The potential function for this vector field is then,

$$f(x, y, z) = x^2 y^3 z^4 + c$$

Note that to keep the work to a minimum we used a fairly simple potential function for this example. It might have been possible to guess what the potential function was based simply on the vector field. However, we should be careful to remember that this usually won't be the case and often this process is required.

Also, there were several other paths that we could have taken to find the potential function. Each would have gotten us the same result.

Let's work one more slightly (and only slightly) more complicated example.

Example 4 Find a potential function for the vector field,

$$\vec{F} = (2x \cos(y) - 2z^3)\vec{i} + (3 + 2ye^z - x^2 \sin(y))\vec{j} + (y^2 e^z - 6xz^2)\vec{k}$$

Solution

Here are the equalities for this vector field.

$$\frac{\partial f}{\partial x} = 2x \cos(y) - 2z^3 \qquad \frac{\partial f}{\partial y} = 3 + 2ye^z - x^2 \sin(y) \qquad \frac{\partial f}{\partial z} = y^2 e^z - 6xz^2$$

For this example let's integrate the third one with respect to z .

$$f(x, y, z) = \int y^2 e^z - 6xz^2 dz = y^2 e^z - 2xz^3 + g(x, y)$$

The "constant of integration" for this integration will be a function of both x and y .

Now, we can differentiate this with respect to x and set it equal to P . Doing this gives,

$$\frac{\partial f}{\partial x} = -2z^3 + g_x(x, y) = 2x \cos(y) - 2z^3 = P$$

So, it looks like we've now got the following,

$$g_x(x, y) = 2x \cos(y) \quad \Rightarrow \quad g(x, y) = x^2 \cos(y) + h(y)$$

The potential function for this problem is then,

$$f(x, y, z) = y^2 e^z - 2xz^3 + x^2 \cos(y) + h(y)$$

To finish this out all we need to do is differentiate with respect to y and set the result equal to Q .

$$\frac{\partial f}{\partial y} = 2ye^z - x^2 \sin(y) + h'(y) = 3 + 2ye^z - x^2 \sin(y) = Q$$

So,

$$h'(y) = 3 \quad \Rightarrow \quad h(y) = 3y + c$$

The potential function for this vector field is then,

$$f(x, y, z) = y^2 e^z - 2xz^3 + x^2 \cos(y) + 3y + c$$

So, a little more complicated than the others and there are again many different paths that we could have taken to get the answer.

We need to work one final example in this section.

Example 5 Evaluate $\int_C \vec{F} \cdot d\vec{r}$ where $\vec{F} = (2x^3y^4 + x)\vec{i} + (2x^4y^3 + y)\vec{j}$ and C is given by

$$\vec{r}(t) = (t \cos(\pi t) - 1)\vec{i} + \sin\left(\frac{\pi t}{2}\right)\vec{j}, \quad 0 \leq t \leq 1.$$

Solution

Now, we could use the techniques we discussed when we first looked at [line integrals of vector fields](#) however that would be particularly unpleasant solution.

Instead, let's take advantage of the fact that we know from Example 2a above this vector field is conservative and that a potential function for the vector field is,

$$f(x, y) = \frac{1}{2}x^4y^4 + \frac{1}{2}x^2 + \frac{1}{2}y^2 + c$$

Using this we know that integral must be independent of path and so all we need to do is use the theorem from the previous [section](#) to do the evaluation.

$$\int_C \vec{F} \cdot d\vec{r} = \int_C \nabla f \cdot d\vec{r} = f(\vec{r}(1)) - f(\vec{r}(0))$$

where,

$$\vec{r}(1) = \langle -2, 1 \rangle \quad \vec{r}(0) = \langle -1, 0 \rangle$$

So, the integral is,

$$\begin{aligned} \int_C \vec{F} \cdot d\vec{r} &= f(-2, 1) - f(-1, 0) \\ &= \left(\frac{21}{2} + c\right) - \left(\frac{1}{2} + c\right) \\ &= 10 \end{aligned}$$

Green's Theorem

In this section we are going to investigate the relationship between certain kinds of line integrals (on closed paths) and double integrals.

Let's start off with a simple ([recall](#) that this means that it doesn't cross itself) [closed](#) curve C and let D be the region enclosed by the curve. Here is a sketch of such a curve and region.

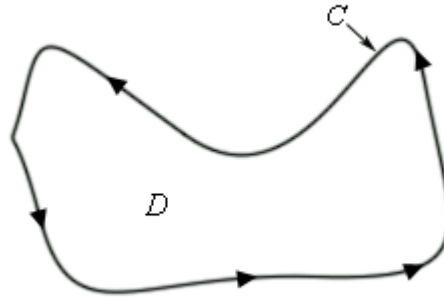

First, notice that because the curve is simple and closed there are no holes in the region D . Also notice that a direction has been put on the curve. We will use the convention here that the curve C has a **positive orientation** if it is traced out in a counter-clockwise direction. Another way to think of a positive orientation (that will cover much more general curves as well see later) is that as we traverse the path following the positive orientation the region D must always be on the left.

Given curves/regions such as this we have the following theorem.

Green's Theorem

Let C be a positively oriented, piecewise smooth, simple, closed curve and let D be the region enclosed by the curve. If P and Q have continuous first order partial derivatives on D then,

$$\int_C Pdx + Qdy = \iint_D \left(\frac{\partial Q}{\partial x} - \frac{\partial P}{\partial y} \right) dA$$

Before working some examples there are some alternate notations that we need to acknowledge. When working with a line integral in which the path satisfies the condition of Green's Theorem we will often denote the line integral as,

$$\oint_C Pdx + Qdy \quad \text{or} \quad \oint_C Pdx + Qdy$$

Both of these notations do assume that C satisfies the conditions of Green's Theorem so be careful in using them.

Also, sometimes the curve C is not thought of as a separate curve but instead as the boundary of some region D and in these cases you may see C denoted as ∂D .

Let's work a couple of examples.

Example 1 Use Green's Theorem to evaluate $\oint_C xy \, dx + x^2 y^3 \, dy$ where C is the triangle with vertices $(0,0)$, $(1,0)$, $(1,2)$ with positive orientation.

Solution

Let's first sketch C and D for this case to make sure that the conditions of Green's Theorem are met for C and will need the sketch of D to evaluate the double integral.

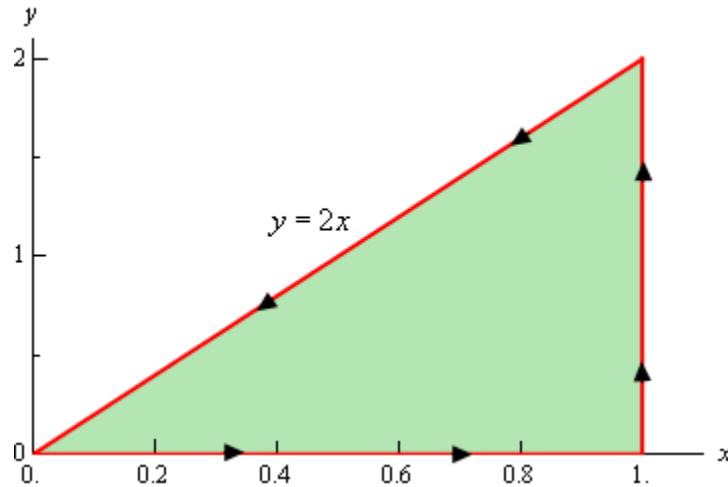

So, the curve does satisfy the conditions of Green's Theorem and we can see that the following inequalities will define the region enclosed.

$$0 \leq x \leq 1 \qquad 0 \leq y \leq 2x$$

We can identify P and Q from the line integral. Here they are.

$$P = xy \qquad Q = x^2 y^3$$

So, using Green's Theorem the line integral becomes,

$$\begin{aligned} \oint_C xy \, dx + x^2 y^3 \, dy &= \iint_D 2xy^3 - x \, dA \\ &= \int_0^1 \int_0^{2x} 2xy^3 - x \, dy \, dx \\ &= \int_0^1 \left(\frac{1}{2} xy^4 - xy \right) \Big|_0^{2x} dx \\ &= \int_0^1 8x^5 - 2x^2 \, dx \\ &= \left(\frac{4}{3} x^6 - \frac{2}{3} x^3 \right) \Big|_0^1 \\ &= \frac{2}{3} \end{aligned}$$

Example 2 Evaluate $\oint_C y^3 dx - x^3 dy$ where C is the positively oriented circle of radius 2 centered at the origin.

Solution

Okay, a circle will satisfy the conditions of Green's Theorem since it is closed and simple and so there really isn't a reason to sketch it.

Let's first identify P and Q from the line integral.

$$P = y^3 \quad Q = -x^3$$

Be careful with the minus sign on Q !

Now, using Green's theorem on the line integral gives,

$$\oint_C y^3 dx - x^3 dy = \iint_D -3x^2 - 3y^2 dA$$

where D is a disk of radius 2 centered at the origin.

Since D is a disk it seems like the best way to do this integral is to use polar coordinates. Here is the evaluation of the integral.

$$\begin{aligned} \oint_C y^3 dx - x^3 dy &= -3 \iint_D (x^2 + y^2) dA \\ &= -3 \int_0^{2\pi} \int_0^2 r^3 dr d\theta \\ &= -3 \int_0^{2\pi} \left. \frac{1}{4} r^4 \right|_0^2 d\theta \\ &= -3 \int_0^{2\pi} 4 d\theta \\ &= -24\pi \end{aligned}$$

So, Green's theorem, as stated, will not work on regions that have holes in them. However, many regions do have holes in them. So, let's see how we can deal with those kinds of regions.

Let's start with the following region. Even though this region doesn't have any holes in it the arguments that we're going to go through will be similar to those that we'd need for regions with holes in them, except it will be a little easier to deal with and write down.

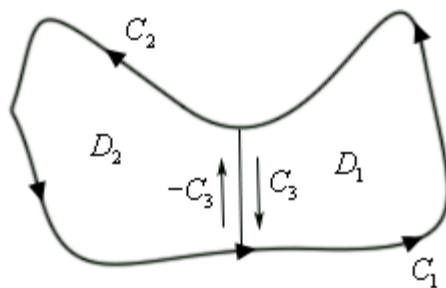

The region D will be $D_1 \cup D_2$ and recall that the symbol \cup is called the union and means that we'll D consists of both D_1 and D_2 . The boundary of D_1 is $C_1 \cup C_3$ while the boundary of D_2 is $C_2 \cup (-C_3)$ and notice that both of these boundaries are positively oriented. As we traverse each boundary the corresponding region is always on the left. Finally, also note that we can think of the whole boundary, C , as,

$$C = (C_1 \cup C_3) \cup (C_2 \cup (-C_3)) = C_1 \cup C_2$$

since both C_3 and $-C_3$ will "cancel" each other out.

Now, let's start with the following double integral and use a basic property of double integrals to break it up.

$$\iint_D (Q_x - P_y) dA = \iint_{D_1 \cup D_2} (Q_x - P_y) dA = \iint_{D_1} (Q_x - P_y) dA + \iint_{D_2} (Q_x - P_y) dA$$

Next, use Green's theorem on each of these and again use the fact that we can break up line integrals into separate line integrals for each portion of the boundary.

$$\begin{aligned} \iint_D (Q_x - P_y) dA &= \iint_{D_1} (Q_x - P_y) dA + \iint_{D_2} (Q_x - P_y) dA \\ &= \oint_{C_1 \cup C_3} P dx + Q dy + \oint_{C_2 \cup (-C_3)} P dx + Q dy \\ &= \oint_{C_1} P dx + Q dy + \oint_{C_3} P dx + Q dy + \oint_{C_2} P dx + Q dy + \oint_{-C_3} P dx + Q dy \end{aligned}$$

Next, we'll use the fact that,

$$\oint_{-C_3} P dx + Q dy = -\oint_{C_3} P dx + Q dy$$

Recall that changing the orientation of a curve with line integrals with respect to x and/or y will simply change the sign on the integral. Using this fact we get,

$$\begin{aligned}\iint_D (Q_x - P_y) dA &= \oint_{C_1} Pdx + Qdy + \oint_{C_3} Pdx + Qdy + \oint_{C_2} Pdx + Qdy - \oint_{C_3} Pdx + Qdy \\ &= \oint_{C_1} Pdx + Qdy + \oint_{C_2} Pdx + Qdy\end{aligned}$$

Finally, put the line integrals back together and we get,

$$\begin{aligned}\iint_D (Q_x - P_y) dA &= \oint_{C_1} Pdx + Qdy + \oint_{C_2} Pdx + Qdy \\ &= \oint_{C_1 \cup C_2} Pdx + Qdy \\ &= \oint_C Pdx + Qdy\end{aligned}$$

So, what did we learn from this? If you think about it this was just a lot of work and all we got out of it was the result from Green's Theorem which we already knew to be true. What this exercise has shown us is that if we break a region up as we did above then the portion of the line integral on the pieces of the curve that are in the middle of the region (each of which are in the opposite direction) will cancel out. This idea will help us in dealing with regions that have holes in them.

To see this let's look at a ring.

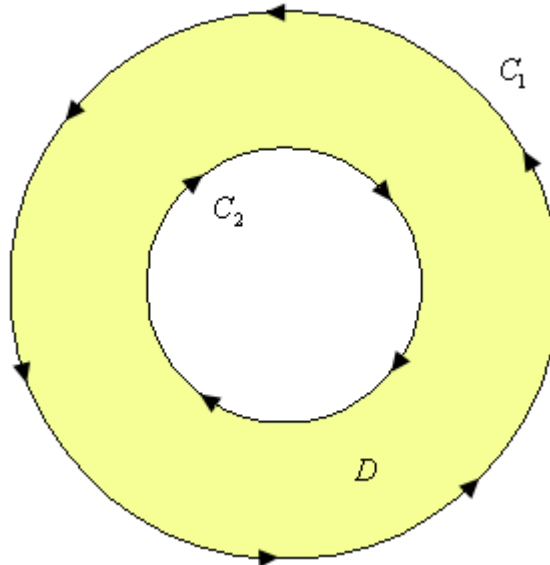

Notice that both of the curves are oriented positively since the region D is on the left side as we traverse the curve in the indicated direction. Note as well that the curve C_2 seems to violate the original definition of positive orientation. We originally said that a curve had a positive orientation if it was traversed in a counter-clockwise direction. However, this was only for regions that do not have holes. For the boundary of the hole this definition won't work and we need to resort to the second definition that we gave above.

Now, since this region has a hole in it we will apparently not be able to use Green's Theorem on any line integral with the curve $C = C_1 \cup C_2$. However, if we cut the disk in half and rename all the various portions of the curves we get the following sketch.

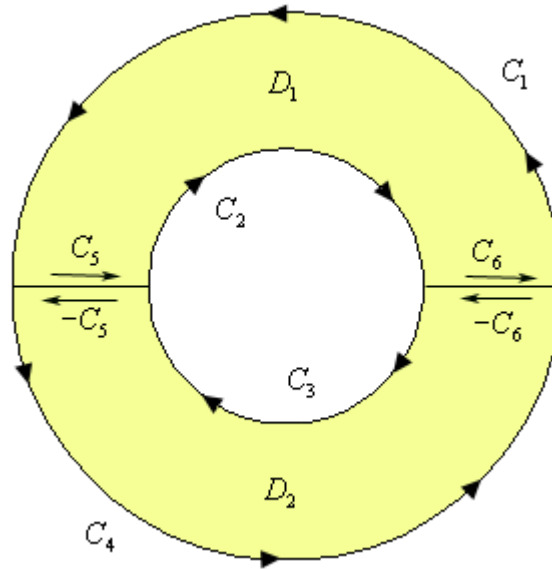

The boundary of the upper portion (D_1) of the disk is $C_1 \cup C_2 \cup C_5 \cup C_6$ and the boundary on the lower portion (D_2) of the disk is $C_3 \cup C_4 \cup (-C_5) \cup (-C_6)$. Also notice that we can use Green's Theorem on each of these new regions since they don't have any holes in them. This means that we can do the following,

$$\begin{aligned} \iint_D (Q_x - P_y) dA &= \iint_{D_1} (Q_x - P_y) dA + \iint_{D_2} (Q_x - P_y) dA \\ &= \oint_{C_1 \cup C_2 \cup C_5 \cup C_6} Pdx + Qdy + \oint_{C_3 \cup C_4 \cup (-C_5) \cup (-C_6)} Pdx + Qdy \end{aligned}$$

Now, we can break up the line integrals into line integrals on each piece of the boundary. Also recall from the work above that boundaries that have the same curve, but opposite direction will cancel. Doing this gives,

$$\begin{aligned} \iint_D (Q_x - P_y) dA &= \iint_{D_1} (Q_x - P_y) dA + \iint_{D_2} (Q_x - P_y) dA \\ &= \oint_{C_1} Pdx + Qdy + \oint_{C_2} Pdx + Qdy + \oint_{C_3} Pdx + Qdy + \oint_{C_4} Pdx + Qdy \end{aligned}$$

But at this point we can add the line integrals back up as follows,

$$\begin{aligned} \iint_D (Q_x - P_y) dA &= \oint_{C_1 \cup C_2 \cup C_3 \cup C_4} Pdx + Qdy \\ &= \oint_C Pdx + Qdy \end{aligned}$$

The end result of all of this is that we could have just used Green's Theorem on the disk from the start even though there is a hole in it. This will be true in general for regions that have holes in them.

Let's take a look at an example.

Example 3 Evaluate $\oint_C y^3 dx - x^3 dy$ where C are the two circles of radius 2 and radius 1 centered at the origin with positive orientation.

Solution

Notice that this is the same line integral as we looked at in the second example and only the curve has changed. In this case the region D will now be the region between these two circles and that will only change the limits in the double integral so we'll not put in some of the details here.

Here is the work for this integral.

$$\begin{aligned}\oint_C y^3 dx - x^3 dy &= -3 \iint_D (x^2 + y^2) dA \\ &= -3 \int_0^{2\pi} \int_1^2 r^3 dr d\theta \\ &= -3 \int_0^{2\pi} \left. \frac{1}{4} r^4 \right|_1^2 d\theta \\ &= -3 \int_0^{2\pi} \frac{15}{4} d\theta \\ &= -\frac{45\pi}{2}\end{aligned}$$

We will close out this section with an interesting application of Green's Theorem. Recall that we can determine the area of a region D with the following double integral.

$$A = \iint_D dA$$

Let's think of this double integral as the result of using Green's Theorem. In other words, let's assume that

$$Q_x - P_y = 1$$

and see if we can get some functions P and Q that will satisfy this.

There are many functions that will satisfy this. Here are some of the more common functions.

$$\begin{array}{l|l|l} P = 0 & P = -y & P = -\frac{y}{2} \\ Q = x & Q = 0 & Q = \frac{x}{2} \end{array}$$

Then, if we use Green's Theorem in reverse we see that the area of the region D can also be computed by evaluating any of the following line integrals.

$$A = \oint_C x dy = -\oint_C y dx = \frac{1}{2} \oint_C x dy - y dx$$

where C is the boundary of the region D .

Let's take a quick look at an example of this.

Example 4 Use Green's Theorem to find the area of a disk of radius a .

Solution

We can use either of the integrals above, but the third one is probably the easiest. So,

$$A = \frac{1}{2} \oint_C x dy - y dx$$

where C is the circle of radius a . So, to do this we'll need a parameterization of C . This is,

$$x = a \cos t \quad y = a \sin t \quad 0 \leq t \leq 2\pi$$

The area is then,

$$\begin{aligned} A &= \frac{1}{2} \oint_C x dy - y dx \\ &= \frac{1}{2} \left(\int_0^{2\pi} a \cos t (a \cos t) dt - \int_0^{2\pi} a \sin t (-a \sin t) dt \right) \\ &= \frac{1}{2} \int_0^{2\pi} a^2 \cos^2 t + a^2 \sin^2 t dt \\ &= \frac{1}{2} \int_0^{2\pi} a^2 dt \\ &= \pi a^2 \end{aligned}$$

Curl and Divergence

In this section we are going to introduce a couple of new concepts, the curl and the divergence of a vector.

Let's start with the curl. Given the vector field $\vec{F} = P\vec{i} + Q\vec{j} + R\vec{k}$ the curl is defined to be,

$$\text{curl } \vec{F} = (R_y - Q_z)\vec{i} + (P_z - R_x)\vec{j} + (Q_x - P_y)\vec{k}$$

There is another (potentially) easier definition of the curl of a vector field. We use it we will first need to define the ∇ operator. This is defined to be,

$$\nabla = \frac{\partial}{\partial x} \vec{i} + \frac{\partial}{\partial y} \vec{j} + \frac{\partial}{\partial z} \vec{k}$$

We use this as if it's a function in the following manner.

$$\nabla f = \frac{\partial f}{\partial x} \vec{i} + \frac{\partial f}{\partial y} \vec{j} + \frac{\partial f}{\partial z} \vec{k}$$

So, whatever function is listed after the ∇ is substituted into the partial derivatives. Note as well that when we look at it in this light we simply get the gradient vector.

Using the ∇ we can define the curl as the following cross product,

$$\text{curl } \vec{F} = \nabla \times \vec{F} = \begin{vmatrix} \vec{i} & \vec{j} & \vec{k} \\ \frac{\partial}{\partial x} & \frac{\partial}{\partial y} & \frac{\partial}{\partial z} \\ P & Q & R \end{vmatrix}$$

We have a couple of nice facts that use the curl of a vector field.

Facts

1. If $f(x, y, z)$ has continuous second order partial derivatives then $\text{curl}(\nabla f) = \vec{0}$. This is easy enough to check by plugging into the definition of the derivative so we'll leave it to you to check.
2. If \vec{F} is a conservative vector field then $\text{curl } \vec{F} = \vec{0}$. This is a direct result of what it means to be a conservative vector field and the previous fact.
3. If \vec{F} is defined on all of \mathbb{R}^3 whose components have continuous first order partial derivative and $\text{curl } \vec{F} = \vec{0}$ then \vec{F} is a conservative vector field. This is not so easy to verify and so we won't try.

Example 1 Determine if $\vec{F} = x^2y\vec{i} + xyz\vec{j} - x^2y^2\vec{k}$ is a conservative vector field.

Solution

So all that we need to do is compute the curl and see if we get the zero vector or not.

$$\begin{aligned}\text{curl } \vec{F} &= \begin{vmatrix} \vec{i} & \vec{j} & \vec{k} \\ \frac{\partial}{\partial x} & \frac{\partial}{\partial y} & \frac{\partial}{\partial z} \\ x^2y & xyz & -x^2y^2 \end{vmatrix} \\ &= -2x^2y\vec{i} + yz\vec{k} - (-2xy^2\vec{j}) - xy\vec{i} - x^2\vec{k} \\ &= -(2x^2y + xy)\vec{i} + 2xy^2\vec{j} + (yz - x^2)\vec{k} \\ &\neq \vec{0}\end{aligned}$$

So, the curl isn't the zero vector and so this vector field is not conservative.

Next we should talk about a physical interpretation of the curl. Suppose that \vec{F} is the velocity field of a flowing fluid. Then $\text{curl } \vec{F}$ represents the tendency of particles at the point (x, y, z) to rotate about the axis that points in the direction of $\text{curl } \vec{F}$. If $\text{curl } \vec{F} = \vec{0}$ then the fluid is called irrotational.

Let's now talk about the second new concept in this section. Given the vector field

$\vec{F} = P\vec{i} + Q\vec{j} + R\vec{k}$ the divergence is defined to be,

$$\text{div } \vec{F} = \frac{\partial P}{\partial x} + \frac{\partial Q}{\partial y} + \frac{\partial R}{\partial z}$$

There is also a definition of the divergence in terms of the ∇ operator. The divergence can be defined in terms of the following dot product.

$$\text{div } \vec{F} = \nabla \cdot \vec{F}$$

Example 2 Compute $\text{div } \vec{F}$ for $\vec{F} = x^2y\vec{i} + xyz\vec{j} - x^2y^2\vec{k}$

Solution

There really isn't much to do here other than compute the divergence.

$$\text{div } \vec{F} = \frac{\partial}{\partial x}(x^2y) + \frac{\partial}{\partial y}(xyz) + \frac{\partial}{\partial z}(-x^2y^2) = 2xy + xz$$

We also have the following fact about the relationship between the curl and the divergence.

$$\text{div}(\text{curl } \vec{F}) = 0$$

Example 3 Verify the above fact for the vector field $\vec{F} = yz^2 \vec{i} + xy \vec{j} + yz \vec{k}$.

Solution

Let's first compute the curl.

$$\begin{aligned}\text{curl } \vec{F} &= \begin{vmatrix} \vec{i} & \vec{j} & \vec{k} \\ \frac{\partial}{\partial x} & \frac{\partial}{\partial y} & \frac{\partial}{\partial z} \\ yz^2 & xy & yz \end{vmatrix} \\ &= z \vec{i} + 2yz \vec{j} + y \vec{k} - z^2 \vec{k} \\ &= z \vec{i} + 2yz \vec{j} + (y - z^2) \vec{k}\end{aligned}$$

Now compute the divergence of this.

$$\text{div}(\text{curl } \vec{F}) = \frac{\partial}{\partial x}(z) + \frac{\partial}{\partial y}(2yz) + \frac{\partial}{\partial z}(y - z^2) = 2z - 2z = 0$$

We also have a physical interpretation of the divergence. If we again think of \vec{F} as the velocity field of a flowing fluid then $\text{div } \vec{F}$ represents the net rate of change of the mass of the fluid flowing from the point (x, y, z) per unit volume. This can also be thought of as the tendency of a fluid to diverge from a point. If $\text{div } \vec{F} = 0$ then the \vec{F} is called incompressible.

The next topic that we want to briefly mention is the **Laplace** operator. Let's first take a look at,

$$\text{div}(\nabla f) = \nabla \cdot \nabla f = f_{xx} + f_{yy} + f_{zz}$$

The Laplace operator is then defined as,

$$\nabla^2 = \nabla \cdot \nabla$$

The Laplace operator arises naturally in many fields including heat transfer and fluid flow.

The final topic in this section is to give two vector forms of Green's Theorem. The first form uses the curl of the vector field and is,

$$\oint_C \vec{F} \cdot d\vec{r} = \iint_D (\text{curl } \vec{F}) \cdot \vec{k} \, dA$$

where \vec{k} is the standard unit vector in the positive z direction.

The second form uses the divergence. In this case we also need the outward unit normal to the curve C . If the curve is parameterized by

$$\vec{r}(t) = x(t)\vec{i} + y(t)\vec{j}$$

then the outward unit normal is given by,

$$\vec{n} = \frac{y'(t)}{\|\vec{r}'(t)\|} \vec{i} - \frac{x'(t)}{\|\vec{r}'(t)\|} \vec{j}$$

Here is a sketch illustrating the outward unit normal for some curve C at various points.

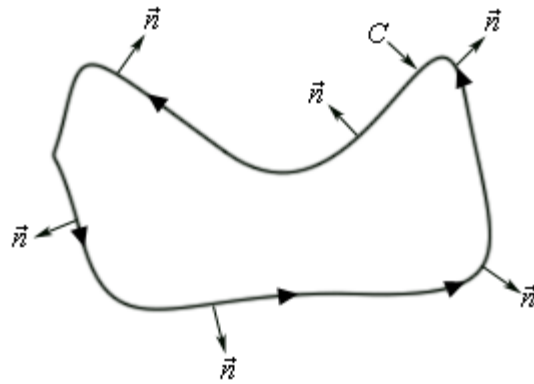

The vector form of Green's Theorem that uses the divergence is given by,

$$\oint_C \vec{F} \cdot \vec{n} \, ds = \iint_D \operatorname{div} \vec{F} \, dA$$

Surface Integrals

Introduction

In the previous chapter we looked at evaluating integrals of functions or vector fields where the points came from a curve in two- or three-dimensional space. We now want to extend this idea and integrate functions and vector fields where the points come from a surface in three-dimensional space. These integrals are called surface integrals.

Here is a list of the topics covered in this chapter.

Parametric Surfaces – In this section we will take a look at the basics of representing a surface with parametric equations. We will also take a look at a couple of applications.

Surface Integrals – Here we will introduce the topic of surface integrals. We will be working with surface integrals of functions in this section.

Surface Integrals of Vector Fields – We will look at surface integrals of vector fields in this section.

Stokes' Theorem – We will look at Stokes' Theorem in this section.

Divergence Theorem – Here we will take a look at the Divergence Theorem.

Parametric Surfaces

Before we get into surface integrals we first need to talk about how to parameterize a surface. When we parameterized a curve we took values of t from some interval $[a, b]$ and plugged them into

$$\vec{r}(t) = x(t)\vec{i} + y(t)\vec{j} + z(t)\vec{k}$$

and the resulting set of vectors will be the position vectors for the points on the curve.

With surfaces we'll do something similar. We will take points, (u, v) , out of some two-dimensional space D and plug them into

$$\vec{r}(u, v) = x(u, v)\vec{i} + y(u, v)\vec{j} + z(u, v)\vec{k}$$

and the resulting set of vectors will be the position vectors for the points on the surface S that we are trying to parameterize. This is often called the **parametric representation** of the **parametric surface** S .

We will sometimes need to write the **parametric equations** for a surface. There are really nothing more than the components of the parametric representation explicitly written down.

$$x = x(u, v) \qquad y = y(u, v) \qquad z = z(u, v)$$

Example 1 Determine the surface given by the parametric representation

$$\vec{r}(u, v) = u\vec{i} + u \cos v \vec{j} + u \sin v \vec{k}$$

Solution

Let's first write down the parametric equations.

$$x = u \qquad y = u \cos v \qquad z = u \sin v$$

Now if we square y and z and then add them together we get,

$$y^2 + z^2 = u^2 \cos^2 v + u^2 \sin^2 v = u^2 (\cos^2 v + \sin^2 v) = u^2 = x^2$$

So, we were able to eliminate the parameters and the equation in $x, y,$ and z is given by,

$$x^2 = y^2 + z^2$$

From the [Quadric Surfaces](#) section notes we can see that this is a cone that opens along the x -axis.

We are much more likely to need to be able to write down the parametric equations of a surface than identify the surface from the parametric representation so let's take a look at some examples of this.

Example 2 Give parametric representations for each of the following surfaces.

- (a) The elliptic paraboloid $x = 5y^2 + 2z^2 - 10$. [\[Solution\]](#)
- (b) The elliptic paraboloid $x = 5y^2 + 2z^2 - 10$ that is in front of the yz -plane. [\[Solution\]](#)
- (c) The sphere $x^2 + y^2 + z^2 = 30$. [\[Solution\]](#)
- (d) The cylinder $y^2 + z^2 = 25$. [\[Solution\]](#)

Solution

(a) The elliptic paraboloid $x = 5y^2 + 2z^2 - 10$.

This one is probably the easiest one of the four to see how to do. Since the surface is in the form $x = f(y, z)$ we can quickly write down a set of parametric equations as follows,

$$x = 5y^2 + 2z^2 - 10 \quad y = y \quad z = z$$

The last two equations are just there to acknowledge that we can choose y and z to be anything we want them to be. The parametric representation is then,

$$\vec{r}(y, z) = (5y^2 + 2z^2 - 10)\vec{i} + y\vec{j} + z\vec{k}$$

[\[Return to Problems\]](#)

(b) The elliptic paraboloid $x = 5y^2 + 2z^2 - 10$ **that is in front of the yz -plane.**

This is really a restriction on the previous parametric representation. The parametric representation stays the same.

$$\vec{r}(y, z) = (5y^2 + 2z^2 - 10)\vec{i} + y\vec{j} + z\vec{k}$$

However, since we only want the surface that lies in front of the yz -plane we also need to require that $x \geq 0$. This is equivalent to requiring,

$$5y^2 + 2z^2 - 10 \geq 0 \quad \text{or} \quad 5y^2 + 2z^2 \geq 10$$

[\[Return to Problems\]](#)

(c) The sphere $x^2 + y^2 + z^2 = 30$.

This one can be a little tricky until you see how to do it. In spherical coordinates we know that the equation of a sphere of radius a is given by,

$$\rho = a$$

and so the equation of this sphere (in spherical coordinates) is $\rho = \sqrt{30}$. Now, we also have the following conversion formulas for converting Cartesian coordinates into spherical coordinates.

$$x = \rho \sin \varphi \cos \theta \quad y = \rho \sin \varphi \sin \theta \quad z = \rho \cos \varphi$$

However, we know what ρ is for our sphere and so if we plug this into these conversion formulas we will arrive at a parametric representation for the sphere. Therefore, the parametric representation is,

$$\vec{r}(\theta, \varphi) = \sqrt{30} \sin \varphi \cos \theta \vec{i} + \sqrt{30} \sin \varphi \sin \theta \vec{j} + \sqrt{30} \cos \varphi \vec{k}$$

All we need to do now is come up with some restriction on the variables. First we know that we have the following restriction.

$$0 \leq \varphi \leq \pi$$

This is enforced upon us by choosing to use spherical coordinates. Also, to make sure that we only trace out the sphere once we will also have the following restriction.

$$0 \leq \theta \leq 2\pi$$

[\[Return to Problems\]](#)

(d) The cylinder $y^2 + z^2 = 25$.

As with the last one this can be tricky until you see how to do it. In this case it makes some sense to use cylindrical coordinates since they can be easily used to write down the equation of a cylinder.

In cylindrical coordinates the equation of a cylinder of radius a is given by

$$r = a$$

and so the equation of the cylinder in this problem is $r = 5$.

Next, we have the following conversion formulas.

$$x = r \cos \theta \quad y = r \sin \theta \quad z = z$$

Notice that they are slightly different from those that we are used to seeing. We needed to change them up here since the cylinder was centered upon the x -axis.

Finally, we know what r is so we can easily write down a parametric representation for this cylinder.

$$\vec{r}(x, \theta) = x \vec{i} + 5 \sin \theta \vec{j} + 5 \cos \theta \vec{k}$$

We will also need the restriction $0 \leq \theta \leq 2\pi$ to make sure that we don't retrace any portion of the cylinder. Since we haven't put any restrictions on the "height" of the cylinder there won't be any restriction on x .

[\[Return to Problems\]](#)

In the first part of this example we used the fact that the function was in the form $x = f(y, z)$ to quickly write down a parametric representation. This can always be done for functions that are in this basic form.

$$\begin{aligned} z = f(x, y) &\Rightarrow \vec{r}(x, y) = x \vec{i} + y \vec{j} + f(x, y) \vec{k} \\ x = f(y, z) &\Rightarrow \vec{r}(x, y) = f(y, z) \vec{i} + y \vec{j} + z \vec{k} \\ y = f(x, z) &\Rightarrow \vec{r}(x, y) = x \vec{i} + f(x, z) \vec{j} + z \vec{k} \end{aligned}$$

Okay, now that we have practice writing down some parametric representations for some surfaces let's take a quick look at a couple of applications.

Let's take a look at finding the tangent plane to the parametric surface S given by,

$$\vec{r}(u, v) = x(u, v) \vec{i} + y(u, v) \vec{j} + z(u, v) \vec{k}$$

First, define

$$\begin{aligned} \vec{r}_u(u, v) &= \frac{\partial x}{\partial u}(u, v) \vec{i} + \frac{\partial y}{\partial u}(u, v) \vec{j} + \frac{\partial z}{\partial u}(u, v) \vec{k} \\ \vec{r}_v(u, v) &= \frac{\partial x}{\partial v}(u, v) \vec{i} + \frac{\partial y}{\partial v}(u, v) \vec{j} + \frac{\partial z}{\partial v}(u, v) \vec{k} \end{aligned}$$

Now, provided $\vec{r}_u \times \vec{r}_v \neq \vec{0}$ it can be shown that the vector $\vec{r}_u \times \vec{r}_v$ will be orthogonal to the surface S . This means that it can be used for the normal vector that we need in order to write down the equation of a tangent plane. This is an important idea that will be used many times throughout the next couple of sections.

Let's take a look at an example.

Example 3 Find the equation of the tangent plane to the surface given by

$$\vec{r}(u, v) = u\vec{i} + 2v^2\vec{j} + (u^2 + v)\vec{k}$$

at the point $(2, 2, 3)$.

Solution

Let's first compute $\vec{r}_u \times \vec{r}_v$. Here are the two individual vectors.

$$\vec{r}_u(u, v) = \vec{i} + 2u\vec{k} \qquad \vec{r}_v(u, v) = 4v\vec{j} + \vec{k}$$

Now the cross product (which will give us the normal vector \vec{n}) is,

$$\vec{n} = \vec{r}_u \times \vec{r}_v = \begin{vmatrix} \vec{i} & \vec{j} & \vec{k} \\ 1 & 0 & 2u \\ 0 & 4v & 1 \end{vmatrix} = -8uv\vec{i} - \vec{j} + 4v\vec{k}$$

Now, this is all fine, but in order to use it we will need to determine the value of u and v that will give us the point in question. We can easily do this by setting the individual components of the parametric representation equal to the coordinates of the point in question. Doing this gives,

$$\begin{aligned} 2 &= u & \Rightarrow & u = 2 \\ 2 &= 2v^2 & \Rightarrow & v = \pm 1 \\ 3 &= u^2 + v \end{aligned}$$

Now, as shown, we have the value of u , but there are two possible values of v . To determine the correct value of v let's plug u into the third equation and solve for v . This should tell us what the correct value is.

$$3 = 4 + v \quad \Rightarrow \quad v = -1$$

Okay so we now know that we'll be at the point in question when $u = 2$ and $v = -1$. At this point the normal vector is,

$$\vec{n} = 16\vec{i} - \vec{j} - 4\vec{k}$$

The tangent plane is then,

$$\begin{aligned} 16(x-2) - (y-2) - 4(z-3) &= 0 \\ 16x - y - 4z &= 18 \end{aligned}$$

You do [remember](#) how to write down the equation of a plane, right?

The second application that we want to take a quick look at is the surface area of the parametric surface S given by,

$$\vec{r}(u, v) = x(u, v)\vec{i} + y(u, v)\vec{j} + z(u, v)\vec{k}$$

and as we will see it again comes down to needing the vector $\vec{r}_u \times \vec{r}_v$.

So, provided S is traced out exactly once as (u, v) ranges over the points in D the surface area of S is given by,

$$A = \iint_D \|\vec{r}_u \times \vec{r}_v\| dA$$

Let's take a look at an example.

Example 4 Find the surface area of the portion of the sphere of radius 4 that lies inside the cylinder $x^2 + y^2 = 12$ and above the xy -plane.

Solution

Okay we've got a couple of things to do here. First we need the parameterization of the sphere. We parameterized a sphere earlier in this section so there isn't too much to do at this point. Here is the parameterization.

$$\vec{r}(\theta, \varphi) = 4 \sin \varphi \cos \theta \vec{i} + 4 \sin \varphi \sin \theta \vec{j} + 4 \cos \varphi \vec{k}$$

Next we need to determine D . Since we are not restricting how far around the z -axis we are rotating with the sphere we can take the following range for θ .

$$0 \leq \theta \leq 2\pi$$

Now, we need to determine a range for φ . This will take a little work, although it's not too bad. First, let's start with the equation of the sphere.

$$x^2 + y^2 + z^2 = 16$$

Now, if we substitute the equation for the cylinder into this equation we can find the value of z where the sphere and the cylinder intersect.

$$x^2 + y^2 + z^2 = 16$$

$$12 + z^2 = 16$$

$$z^2 = 4 \quad \Rightarrow \quad z = \pm 2$$

Now, since we also specified that we only want the portion of the sphere that lies above the xy -plane we know that we need $z = 2$. We also know that $\rho = 4$. Plugging this into the following conversion formula we get,

$$z = \rho \cos \varphi$$

$$2 = 4 \cos \varphi$$

$$\cos \varphi = \frac{1}{2} \quad \Rightarrow \quad \varphi = \frac{\pi}{3}$$

So, it looks like the range of φ will be,

$$0 \leq \varphi \leq \frac{\pi}{3}$$

Finally, we need to determine $\vec{r}_\theta \times \vec{r}_\varphi$. Here are the two individual vectors.

$$\vec{r}_\theta(\theta, \varphi) = -4 \sin \varphi \sin \theta \vec{i} + 4 \sin \varphi \cos \theta \vec{j}$$

$$\vec{r}_\varphi(\theta, \varphi) = 4 \cos \varphi \cos \theta \vec{i} + 4 \cos \varphi \sin \theta \vec{j} - 4 \sin \varphi \vec{k}$$

Now let's take the cross product.

$$\begin{aligned} \vec{r}_\theta \times \vec{r}_\varphi &= \begin{vmatrix} \vec{i} & \vec{j} & \vec{k} \\ -4 \sin \varphi \sin \theta & 4 \sin \varphi \cos \theta & 0 \\ 4 \cos \varphi \cos \theta & 4 \cos \varphi \sin \theta & -4 \sin \varphi \end{vmatrix} \\ &= -16 \sin^2 \varphi \cos \theta \vec{i} - 16 \sin \varphi \cos \varphi \sin^2 \theta \vec{k} - 16 \sin^2 \varphi \sin \theta \vec{j} - 16 \sin \varphi \cos \varphi \cos^2 \theta \vec{k} \\ &= -16 \sin^2 \varphi \cos \theta \vec{i} - 16 \sin^2 \varphi \sin \theta \vec{j} - 16 \sin \varphi \cos \varphi (\sin^2 \theta + \cos^2 \theta) \vec{k} \\ &= -16 \sin^2 \varphi \cos \theta \vec{i} - 16 \sin^2 \varphi \sin \theta \vec{j} - 16 \sin \varphi \cos \varphi \vec{k} \end{aligned}$$

We now need the magnitude of this,

$$\begin{aligned} \|\vec{r}_\theta \times \vec{r}_\varphi\| &= \sqrt{256 \sin^4 \varphi \cos^2 \theta + 256 \sin^4 \varphi \sin^2 \theta + 256 \sin^2 \varphi \cos^2 \varphi} \\ &= \sqrt{256 \sin^4 \varphi (\cos^2 \theta + \sin^2 \theta) + 256 \sin^2 \varphi \cos^2 \varphi} \\ &= \sqrt{256 \sin^2 \varphi (\sin^2 \varphi + \cos^2 \varphi)} \\ &= 16 \sqrt{\sin^2 \varphi} \\ &= 16 |\sin \varphi| \\ &= 16 \sin \varphi \end{aligned}$$

We can drop the absolute value bars in the sine because sine is positive in the range of φ that we are working with.

We can finally get the surface area.

$$\begin{aligned} A &= \iint_D 16 \sin \varphi \, dA \\ &= \int_0^{2\pi} \int_0^{\pi/3} 16 \sin \varphi \, d\varphi \, d\theta \\ &= \int_0^{2\pi} -16 \cos \varphi \Big|_0^{\pi/3} \, d\theta \\ &= \int_0^{2\pi} 8 \, d\theta \\ &= 16\pi \end{aligned}$$

Surface Integrals

It is now time to think about integrating functions over some surface, S , in three-dimensional space. Let's start off with a sketch of the surface S since the notation can get a little confusing once we get into it. Here is a sketch of some surface S .

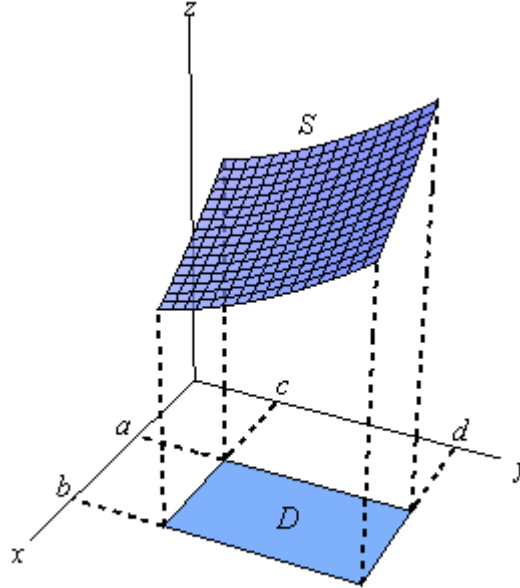

The region S will lie above (in this case) some region D that lies in the xy -plane. We used a rectangle here, but it doesn't have to be of course. Also note that we could just as easily look at a surface S that was in front of some region D in the yz -plane or the xz -plane. Do not get so locked into the xy -plane that you can't do problems that have regions in the other two planes.

Now, how we evaluate the surface integral will depend upon how the surface is given to us. There are essentially two separate methods here, although as we will see they are really the same.

First, let's look at the surface integral in which the surface S is given by $z = g(x, y)$. In this case the surface integral is,

$$\iint_S f(x, y, z) dS = \iint_D f(x, y, g(x, y)) \sqrt{\left(\frac{\partial g}{\partial x}\right)^2 + \left(\frac{\partial g}{\partial y}\right)^2 + 1} dA$$

Now, we need to be careful here as both of these look like standard double integrals. In fact the integral on the right is a standard double integral. The integral on the left however is a surface integral. The way to tell them apart is by looking at the differentials. The surface integral will have a dS while the standard double integral will have a dA .

In order to evaluate a surface integral we will substitute the equation of the surface in for z in the integrand and then add on the often messy square root. After that the integral is a standard double integral and by this point we should be able to deal with that.

Note as well that there are similar formulas for surfaces given by $y = g(x, z)$ (with D in the xz -plane) and $x = g(y, z)$ (with D in the yz -plane). We will see one of these formulas in the examples and we'll leave the other to you to write down.

The second method for evaluating a surface integral is for those surfaces that are given by the parameterization,

$$\vec{r}(u, v) = x(u, v)\vec{i} + y(u, v)\vec{j} + z(u, v)\vec{k}$$

In these cases the surface integral is,

$$\iint_S f(x, y, z) dS = \iint_D f(\vec{r}(u, v)) \|\vec{r}_u \times \vec{r}_v\| dA$$

where D is the range of the parameters that trace out the surface S .

Before we work some examples let's notice that since we can parameterize a surface given by $z = g(x, y)$ as,

$$\vec{r}(x, y) = x\vec{i} + y\vec{j} + g(x, y)\vec{k}$$

we can always use this form for these kinds of surfaces as well. In fact it can be shown that,

$$\|\vec{r}_x \times \vec{r}_y\| = \sqrt{\left(\frac{\partial g}{\partial x}\right)^2 + \left(\frac{\partial g}{\partial y}\right)^2 + 1}$$

for these kinds of surfaces. You might want to verify this for the practice of computing these cross products.

Let's work some examples.

Example 1 Evaluate $\iint_S 6xy dS$ where S is the portion of the plane $x + y + z = 1$ that lies in front of the yz -plane.

Solution

Okay, since we are looking for the portion of the plane that lies in front of the yz -plane we are going to need to write the equation of the surface in the form $x = g(y, z)$. This is easy enough to do.

$$x = 1 - y - z$$

Next we need to determine just what D is. Here is a sketch of the surface S .

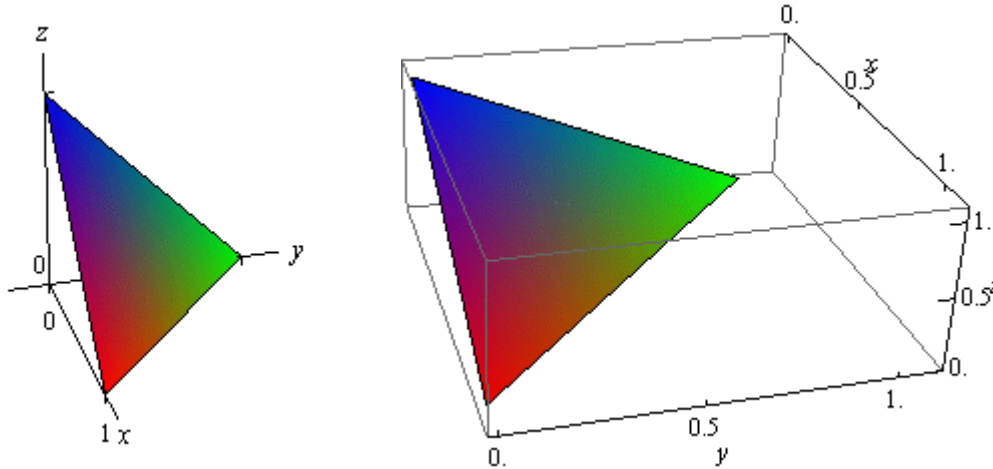

Here is a sketch of the region D .

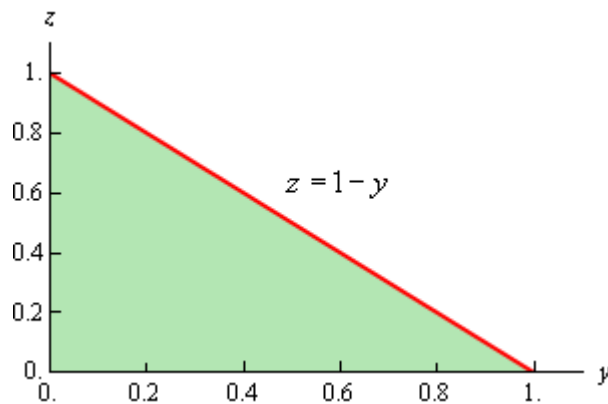

Notice that the axes are labeled differently than we are used to seeing in the sketch of D . This was to keep the sketch consistent with the sketch of the surface. We arrived at the equation of the hypotenuse by setting x equal to zero in the equation of the plane and solving for z . Here are the ranges for y and z .

$$0 \leq y \leq 1 \quad 0 \leq z \leq 1 - y$$

Now, because the surface is not in the form $z = g(x, y)$ we can't use the formula above.

However, as noted above we can modify this formula to get one that will work for us. Here it is,

$$\iint_S f(x, y, z) dS = \iint_D f(g(y, z), y, z) \sqrt{1 + \left(\frac{\partial g}{\partial y}\right)^2 + \left(\frac{\partial g}{\partial z}\right)^2} dA$$

The changes made to the formula should be the somewhat obvious changes. So, let's do the integral.

$$\iint_S 6xy dS = \iint_D 6(1 - y - z)y \sqrt{1 + (-1)^2 + (-1)^2} dA$$

Notice that we plugged in the equation of the plane for the x in the integrand. At this point we've got a fairly simple double integral to do. Here is that work.

$$\begin{aligned}
\iint_S 6xy \, dS &= \sqrt{3} \iint_D 6(y - y^2 - zy) \, dA \\
&= 6\sqrt{3} \int_0^1 \int_0^{1-y} (y - y^2 - zy) \, dz \, dy \\
&= 6\sqrt{3} \int_0^1 \left(yz - zy^2 - \frac{1}{2}z^2 y \right) \Big|_0^{1-y} \, dy \\
&= 6\sqrt{3} \int_0^1 \left(\frac{1}{2}y - y^2 + \frac{1}{2}y^3 \right) \, dy \\
&= 6\sqrt{3} \left(\frac{1}{4}y^2 - \frac{1}{3}y^3 + \frac{1}{8}y^4 \right) \Big|_0^1 = \frac{\sqrt{3}}{4}
\end{aligned}$$

Example 2 Evaluate $\iint_S z \, dS$ where S is the upper half of a sphere of radius 2.

Solution

We gave the parameterization of a sphere in the previous [section](#). Here is the parameterization for this sphere.

$$\vec{r}(\theta, \varphi) = 2 \sin \varphi \cos \theta \vec{i} + 2 \sin \varphi \sin \theta \vec{j} + 2 \cos \varphi \vec{k}$$

Since we are working on the upper half of the sphere here are the limits on the parameters.

$$0 \leq \theta \leq 2\pi \qquad 0 \leq \varphi \leq \frac{\pi}{2}$$

Next, we need to determine $\vec{r}_\theta \times \vec{r}_\varphi$. Here are the two individual vectors.

$$\vec{r}_\theta(\theta, \varphi) = -2 \sin \varphi \sin \theta \vec{i} + 2 \sin \varphi \cos \theta \vec{j}$$

$$\vec{r}_\varphi(\theta, \varphi) = 2 \cos \varphi \cos \theta \vec{i} + 2 \cos \varphi \sin \theta \vec{j} - 2 \sin \varphi \vec{k}$$

Now let's take the cross product.

$$\begin{aligned}
\vec{r}_\theta \times \vec{r}_\varphi &= \begin{vmatrix} \vec{i} & \vec{j} & \vec{k} \\ -2 \sin \varphi \sin \theta & 2 \sin \varphi \cos \theta & 0 \\ 2 \cos \varphi \cos \theta & 2 \cos \varphi \sin \theta & -2 \sin \varphi \end{vmatrix} \\
&= -4 \sin^2 \varphi \cos \theta \vec{i} - 4 \sin \varphi \cos \varphi \sin^2 \theta \vec{k} - 4 \sin^2 \varphi \sin \theta \vec{j} - 4 \sin \varphi \cos \varphi \cos^2 \theta \vec{k} \\
&= -4 \sin^2 \varphi \cos \theta \vec{i} - 4 \sin^2 \varphi \sin \theta \vec{j} - 4 \sin \varphi \cos \varphi (\sin^2 \theta + \cos^2 \theta) \vec{k} \\
&= -4 \sin^2 \varphi \cos \theta \vec{i} - 4 \sin^2 \varphi \sin \theta \vec{j} - 4 \sin \varphi \cos \varphi \vec{k}
\end{aligned}$$

Finally, we need the magnitude of this,

$$\begin{aligned}
\|\vec{r}_\theta \times \vec{r}_\varphi\| &= \sqrt{16 \sin^4 \varphi \cos^2 \theta + 16 \sin^4 \varphi \sin^2 \theta + 16 \sin^2 \varphi \cos^2 \varphi} \\
&= \sqrt{16 \sin^4 \varphi (\cos^2 \theta + \sin^2 \theta) + 16 \sin^2 \varphi \cos^2 \varphi} \\
&= \sqrt{16 \sin^2 \varphi (\sin^2 \varphi + \cos^2 \varphi)} \\
&= 4\sqrt{\sin^2 \varphi} \\
&= 4|\sin \varphi| \\
&= 4 \sin \varphi
\end{aligned}$$

We can drop the absolute value bars in the sine because sine is positive in the range of φ that we are working with. The surface integral is then,

$$\iint_S z \, dS = \iint_D 2 \cos \varphi (4 \sin \varphi) \, dA$$

Don't forget that we need to plug in for x , y and/or z in these as well, although in this case we just needed to plug in z . Here is the evaluation for the double integral.

$$\begin{aligned}
\iint_S z \, dS &= \int_0^{2\pi} \int_0^{\frac{\pi}{2}} 4 \sin(2\varphi) \, d\varphi \, d\theta \\
&= \int_0^{2\pi} (-2 \cos(2\varphi)) \Big|_0^{\frac{\pi}{2}} \, d\theta \\
&= \int_0^{2\pi} 4 \, d\theta \\
&= 8\pi
\end{aligned}$$

Example 3 Evaluate $\iint_S y \, dS$ where S is the portion of the cylinder $x^2 + y^2 = 3$ that lies between $z = 0$ and $z = 6$.

Solution

We parameterized up a cylinder in the previous [section](#). Here is the parameterization of this cylinder.

$$\vec{r}(z, \theta) = \sqrt{3} \cos \theta \vec{i} + \sqrt{3} \sin \theta \vec{j} + z \vec{k}$$

The ranges of the parameters are,

$$0 \leq z \leq 6 \quad 0 \leq \theta \leq 2\pi$$

Now we need $\vec{r}_z \times \vec{r}_\theta$. Here are the two vectors.

$$\vec{r}_z(z, \theta) = \vec{k}$$

$$\vec{r}_\theta(z, \theta) = -\sqrt{3} \sin \theta \vec{i} + \sqrt{3} \cos \theta \vec{j}$$

Here is the cross product.

$$\begin{aligned}\vec{r}_z \times \vec{r}_\theta &= \begin{vmatrix} \vec{i} & \vec{j} & \vec{k} \\ 0 & 0 & 1 \\ -\sqrt{3} \sin \theta & \sqrt{3} \cos \theta & 0 \end{vmatrix} \\ &= -\sqrt{3} \cos \theta \vec{i} - \sqrt{3} \sin \theta \vec{j}\end{aligned}$$

The magnitude of this vector is,

$$\|\vec{r}_z \times \vec{r}_\theta\| = \sqrt{3 \cos^2 \theta + 3 \sin^2 \theta} = \sqrt{3}$$

The surface integral is then,

$$\begin{aligned}\iint_S y \, dS &= \iint_D \sqrt{3} \sin \theta (\sqrt{3}) \, dA \\ &= 3 \int_0^{2\pi} \int_0^6 \sin \theta \, dz \, d\theta \\ &= 3 \int_0^{2\pi} 6 \sin \theta \, d\theta \\ &= (-18 \cos \theta) \Big|_0^{2\pi} \\ &= 0\end{aligned}$$

Example 4 Evaluate $\iint_S y + z \, dS$ where S is the surface whose side is the cylinder $x^2 + y^2 = 3$, whose bottom is the disk $x^2 + y^2 \leq 3$ in the xy -plane and whose top is the plane $z = 4 - y$.

Solution

There is a lot of information that we need to keep track of here. First, we are using pretty much the same surface (the integrand is different however) as the previous example. However, unlike the previous example we are putting a top and bottom on the surface this time. Let's first start out with a sketch of the surface.

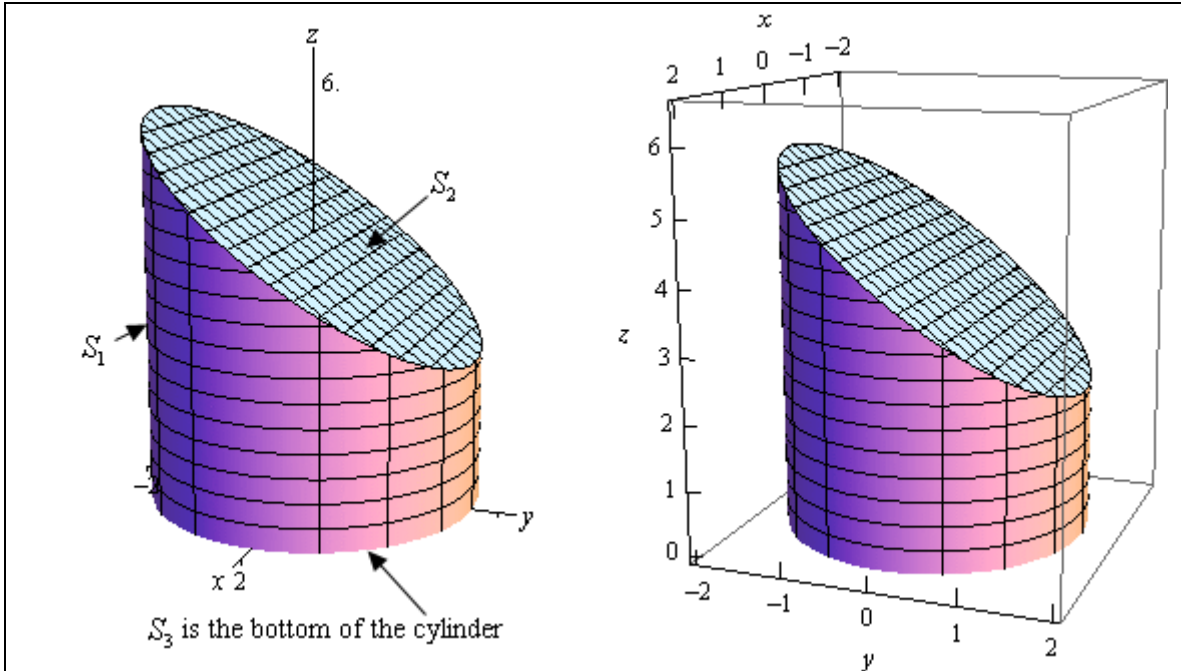

Actually we need to be careful here. There is more to this sketch than the actual surface itself. We're going to let S_1 be the portion of the cylinder that goes from the xy -plane to the plane. In other words, the top of the cylinder will be at an angle. We'll call the portion of the plane that lies inside (*i.e.* the cap on the cylinder) S_2 . Finally, the bottom of the cylinder (not shown here) is the disk of radius $\sqrt{3}$ in the xy -plane and is denoted by S_3 .

In order to do this integral we'll need to note that just like the standard double integral, if the surface is split up into pieces we can also split up the surface integral. So, for our example we will have,

$$\iint_S y + z \, dS = \iint_{S_1} y + z \, dS + \iint_{S_2} y + z \, dS + \iint_{S_3} y + z \, dS$$

We're going to need to do three integrals here. However, we've done most of the work for the first one in the previous example so let's start with that.

S_1 : The Cylinder

The parameterization of the cylinder and $\|\vec{r}_z \times \vec{r}_\theta\|$ is,

$$\vec{r}(z, \theta) = \sqrt{3} \cos \theta \vec{i} + \sqrt{3} \sin \theta \vec{j} + z \vec{k} \qquad \|\vec{r}_z \times \vec{r}_\theta\| = \sqrt{3}$$

The difference between this problem and the previous one is the limits on the parameters. Here they are.

$$0 \leq \theta \leq 2\pi$$

$$0 \leq z \leq 4 - y = 4 - \sqrt{3} \sin \theta$$

The upper limit for the z 's is the plane so we can just plug that in. However, since we are on the cylinder we know what y is from the parameterization so we will also need to plug that in.

Here is the integral for the cylinder.

$$\begin{aligned}
 \iint_{S_1} y + z \, dS &= \iint_D (\sqrt{3} \sin \theta + z)(\sqrt{3}) \, dA \\
 &= \sqrt{3} \int_0^{2\pi} \int_0^{4-\sqrt{3}\sin\theta} \sqrt{3} \sin \theta + z \, dz \, d\theta \\
 &= \sqrt{3} \int_0^{2\pi} \sqrt{3} \sin \theta (4 - \sqrt{3} \sin \theta) + \frac{1}{2} (4 - \sqrt{3} \sin \theta)^2 \, d\theta \\
 &= \sqrt{3} \int_0^{2\pi} 8 - \frac{3}{2} \sin^2 \theta \, d\theta \\
 &= \sqrt{3} \int_0^{2\pi} 8 - \frac{3}{4} (1 - \cos(2\theta)) \, d\theta \\
 &= \sqrt{3} \left(\frac{29}{4} \theta + \frac{3}{8} \sin(2\theta) \right) \Big|_0^{2\pi} \\
 &= \frac{29\sqrt{3}\pi}{2}
 \end{aligned}$$

S_2 : Plane on Top of the Cylinder

In this case we don't need to do any parameterization since it is set up to use the formula that we gave at the start of this section. Remember that the plane is given by $z = 4 - y$. Also note that, for this surface, D is the disk of radius $\sqrt{3}$ centered at the origin.

Here is the integral for the plane.

$$\begin{aligned}
 \iint_{S_2} y + z \, dS &= \iint_D (y + 4 - y) \sqrt{(0)^2 + (-1)^2 + 1} \, dA \\
 &= \sqrt{2} \iint_D 4 \, dA
 \end{aligned}$$

Don't forget that we need to plug in for z ! Now at this point we can proceed in one of two ways. Either we can proceed with the integral or we can recall that $\iint_D dA$ is nothing more than the area of D and we know that D is the disk of radius $\sqrt{3}$ and so there is no reason to do the integral.

Here is the remainder of the work for this problem.

$$\begin{aligned}
 \iint_{S_2} y + z \, dS &= 4\sqrt{2} \iint_D dA \\
 &= 4\sqrt{2} \left(\pi (\sqrt{3})^2 \right) \\
 &= 12\sqrt{2} \pi
 \end{aligned}$$

S_3 : Bottom of the Cylinder

Again, this is set up to use the initial formula we gave in this section once we realize that the equation for the bottom is given by $g(x, y) = 0$ and D is the disk of radius $\sqrt{3}$ centered at the origin. Also, don't forget to plug in for z .

Here is the work for this integral.

$$\begin{aligned}
 \iint_{S_3} y + z \, dS &= \iint_D (y + 0) \sqrt{(0)^2 + (0)^2 + (1)^2} \, dA \\
 &= \iint_D y \, dA \\
 &= \int_0^{2\pi} \int_0^{\sqrt{3}} r^2 \sin \theta \, dr \, d\theta \\
 &= \int_0^{2\pi} \left(\frac{1}{3} r^3 \sin \theta \right) \Big|_0^{\sqrt{3}} \, d\theta \\
 &= \int_0^{2\pi} \sqrt{3} \sin \theta \, d\theta \\
 &= -\sqrt{3} \cos \theta \Big|_0^{2\pi} \\
 &= 0
 \end{aligned}$$

We can now get the value of the integral that we are after.

$$\begin{aligned}
 \iint_S y + z \, dS &= \iint_{S_1} y + z \, dS + \iint_{S_2} y + z \, dS + \iint_{S_3} y + z \, dS \\
 &= \frac{29\sqrt{3} \pi}{2} + 12\sqrt{2} \pi + 0 \\
 &= \frac{\pi}{2} (29\sqrt{3} + 24\sqrt{2})
 \end{aligned}$$

Surface Integrals of Vector Fields

Just as we did with line integrals we now need to move on to surface integrals of vector fields. Recall that in line integrals the orientation of the curve we were integrating along could change the answer. The same thing will hold true with surface integrals. So, before we really get into doing surface integrals of vector fields we first need to introduce the idea of an **oriented surface**.

Let's start off with a surface that has two sides (while this may seem strange, recall that the [Möbius Strip](#) is a surface that only has one side!) that has a tangent plane at every point (except possibly along the boundary). Making this assumption means that every point will have two unit normal vectors, \vec{n}_1 and $\vec{n}_2 = -\vec{n}_1$. This means that every surface will have two sets of normal vectors. The set that we choose will give the surface an orientation.

There is one convention that we will make in regards to certain kinds of oriented surfaces. First we need to define a **closed surface**. A surface S is closed if it is the boundary of some solid region E . A good example of a closed surface is the surface of a sphere. We say that the closed surface S has a **positive** orientation if we choose the set of unit normal vectors that point outward from the region E while the **negative** orientation will be the set of unit normal vectors that point in towards the region E .

Note that this convention is only used for closed surfaces.

In order to work with surface integrals of vector fields we will need to be able to write down a formula for the unit normal vector corresponding to the orientation that we've chosen to work with. We have two ways of doing this depending on how the surface has been given to us.

First, let's suppose that the function is given by $z = g(x, y)$. In this case we first define a new function,

$$f(x, y, z) = z - g(x, y)$$

In terms of our new function the surface is then given by the equation $f(x, y, z) = 0$. Now, [recall](#) that ∇f will be orthogonal (or normal) to the surface given by $f(x, y, z) = 0$. This means that we have a normal vector to the surface. The only potential problem is that it might not be a unit normal vector. That isn't a problem since we also know that we can turn any vector into a unit vector by dividing the vector by its length. In our case this is,

$$\vec{n} = \frac{\nabla f}{\|\nabla f\|}$$

In this case it will be convenient to actually compute the gradient vector and plug this into the formula for the normal vector. Doing this gives,

$$\vec{n} = \frac{\nabla f}{\|\nabla f\|} = \frac{-g_x \vec{i} - g_y \vec{j} + \vec{k}}{\sqrt{(g_x)^2 + (g_y)^2 + 1}}$$

Now, from a notational standpoint this might not have been so convenient, but it does allow us to make a couple of additional comments.

First, notice that the component of the normal vector in the z -direction (identified by the \vec{k} in the normal vector) is always positive and so this normal vector will generally point upwards. It may not point directly up, but it will have an upwards component to it.

This will be important when we are working with a closed surface and we want the positive orientation. If we know that we can then look at the normal vector and determine if the “positive” orientation should point upwards or downwards. Remember that the “positive” orientation must point out of the region and this may mean downwards in places. Of course if it turns out that we need the downward orientation we can always take the negative of this unit vector and we’ll get the one that we need. Again, remember that we always have that option when choosing the unit normal vector.

Before we move onto the second method of giving the surface we should point out that we only did this for surfaces in the form $z = g(x, y)$. We could just as easily done the above work for surfaces in the form $y = g(x, z)$ (so $f(x, y, z) = y - g(x, z)$) or for surfaces in the form $x = g(y, z)$ (so $f(x, y, z) = x - g(y, z)$).

Now, we need to discuss how to find the unit normal vector if the surface is given parametrically as,

$$\vec{r}(u, v) = x(u, v)\vec{i} + y(u, v)\vec{j} + z(u, v)\vec{k}$$

In this case [recall](#) that the vector $\vec{r}_u \times \vec{r}_v$ will be normal to the tangent plane at a particular point. But if the vector is normal to the tangent plane at a point then it will also be normal to the surface at that point. So, this is a normal vector. In order to guarantee that it is a unit normal vector we will also need to divide it by its magnitude.

So, in the case of parametric surfaces one of the unit normal vectors will be,

$$\vec{n} = \frac{\vec{r}_u \times \vec{r}_v}{\|\vec{r}_u \times \vec{r}_v\|}$$

As with the first case we will need to look at this once it’s computed and determine if it points in the correct direction or not. If it doesn’t then we can always take the negative of this vector and that will point in the correct direction.

Finally, remember that we can always parameterize any surface given by $z = g(x, y)$ (or $y = g(x, z)$ or $x = g(y, z)$) easily enough and so if we want to we can always use the parameterization formula to find the unit normal vector.

Okay, now that we’ve looked at oriented surfaces and their associated unit normal vectors we can actually give a formula for evaluating surface integrals of vector fields.

Given a vector field \vec{F} with unit normal vector \vec{n} then the surface integral of \vec{F} over the surface S is given by,

$$\iint_S \vec{F} \cdot d\vec{S} = \iint_S \vec{F} \cdot \vec{n} \, dS$$

where the right hand integral is a standard surface integral. This is sometimes called the **flux of \vec{F} across S** .

Before we work any examples let's notice that we can substitute in for the unit normal vector to get a *somewhat* easier formula to use. We will need to be careful with each of the following formulas however as each will assume a certain orientation and we may have to change the normal vector to match the given orientation.

Let's first start by assuming that the surface is given by $z = g(x, y)$. In this case let's also assume that the vector field is given by $\vec{F} = P\vec{i} + Q\vec{j} + R\vec{k}$ and that the orientation that we are after is the "upwards" orientation. Under all of these assumptions the surface integral of \vec{F} over S is,

$$\begin{aligned} \iint_S \vec{F} \cdot d\vec{S} &= \iint_S \vec{F} \cdot \vec{n} \, dS \\ &= \iint_D (P\vec{i} + Q\vec{j} + R\vec{k}) \cdot \left(\frac{-g_x\vec{i} - g_y\vec{j} + \vec{k}}{\sqrt{(g_x)^2 + (g_y)^2 + 1}} \right) \sqrt{(g_x)^2 + (g_y)^2 + 1} \, dA \\ &= \iint_D (P\vec{i} + Q\vec{j} + R\vec{k}) \cdot (-g_x\vec{i} - g_y\vec{j} + \vec{k}) \, dA \\ &= \iint_D -Pg_x - Qg_y + R \, dA \end{aligned}$$

Now, remember that this assumed the "upward" orientation. If we'd needed the "downward" orientation then we would need to change the signs on the normal vector. This would in turn change the signs on the integrand as well. So, we really need to be careful here when using this formula. In general it is best to rederive this formula as you need it.

When we've been given a surface that is not in parametric form there are in fact 6 possible integrals here. Two for each form of the surface $z = g(x, y)$, $y = g(x, z)$ and $x = g(y, z)$. Given each form of the surface there will be two possible unit normal vectors and we'll need to choose the correct one to match the given orientation of the surface. However, the derivation of each formula is similar to that given here and so shouldn't be too bad to do as you need to.

Notice as well that because we are using the unit normal vector the messy square root will always drop out. This means that when we do need to derive the formula we won't really need to put this in. All we'll need to work with is the numerator of the unit vector. We will see at least one more of these derived in the examples below. It should also be noted that the square root is nothing more than,

$$\sqrt{(g_x)^2 + (g_y)^2 + 1} = \|\nabla f\|$$

so in the following work we will probably just use this notation in place of the square root when we can to make things a little simpler.

Let's now take a quick look at the formula for the surface integral when the surface is given parametrically by $\vec{r}(u, v)$. In this case the surface integral is,

$$\begin{aligned}\iint_S \vec{F} \cdot d\vec{S} &= \iint_S \vec{F} \cdot \vec{n} \, dS \\ &= \iint_D \vec{F} \cdot \left(\frac{\vec{r}_u \times \vec{r}_v}{\|\vec{r}_u \times \vec{r}_v\|} \right) \|\vec{r}_u \times \vec{r}_v\| \, dA \\ &= \iint_D \vec{F} \cdot (\vec{r}_u \times \vec{r}_v) \, dA\end{aligned}$$

Again note that we may have to change the sign on $\vec{r}_u \times \vec{r}_v$ to match the orientation of the surface and so there is once again really two formulas here. Also note that again the magnitude cancels in this case and so we won't need to worry that in these problems either.

Note as well that there are even times when we will use the definition, $\iint_S \vec{F} \cdot d\vec{S} = \iint_S \vec{F} \cdot \vec{n} \, dS$, directly. We will see an example of this below.

Let's now work a couple of examples.

Example 1 Evaluate $\iint_S \vec{F} \cdot d\vec{S}$ where $\vec{F} = y\vec{j} - z\vec{k}$ and S is the surface given by the paraboloid $y = x^2 + z^2$, $0 \leq y \leq 1$ and the disk $x^2 + z^2 \leq 1$ at $y = 1$. Assume that S has positive orientation.

Solution

Okay, first let's notice that the disk is really nothing more than the cap on the paraboloid. This means that we have a closed surface. This is important because we've been told that the surface has a positive orientation and by convention this means that all the unit normal vectors will need to point outwards from the region enclosed by S .

Let's first get a sketch of S so we can get a feel for what is going on and in which direction we will need to unit normal vectors to point.

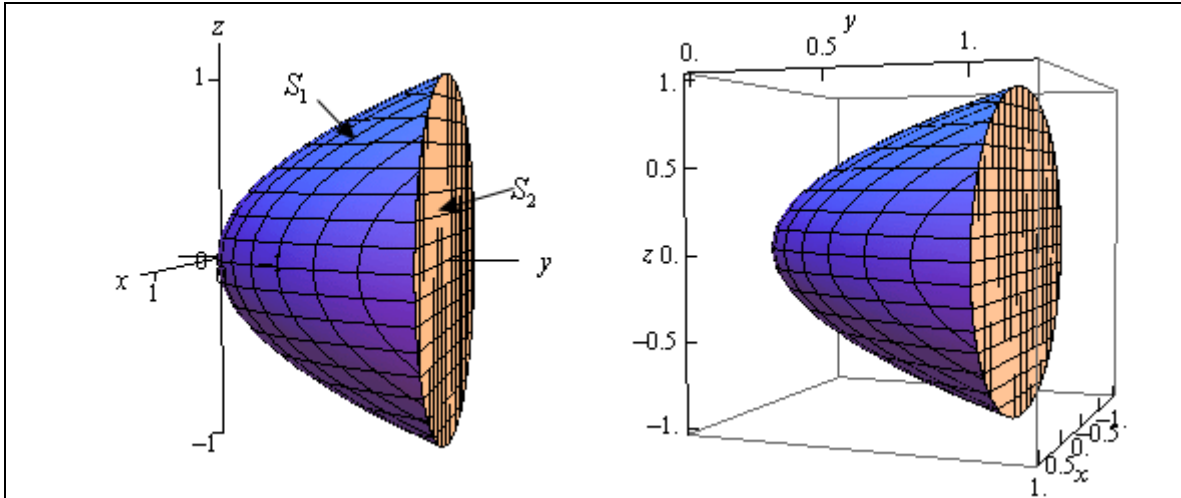

As noted in the sketch we will denote the paraboloid by S_1 and the disk by S_2 . Also note that in order for unit normal vectors on the paraboloid to point away from the region they will all need to point generally in the negative y direction. On the other hand, unit normal vectors on the disk will need to point in the positive y direction in order to point away from the region.

Since S is composed of the two surfaces we'll need to do the surface integral on each and then add the results to get the overall surface integral. Let's start with the paraboloid. In this case we have the surface in the form $y = g(x, z)$ so we will need to derive the correct formula since the one given initially wasn't for this kind of function. This is easy enough to do however. First define,

$$f(x, y, z) = y - g(x, z) = y - x^2 - z^2$$

We will next need the gradient vector of this function.

$$\nabla f = \langle -2x, 1, -2z \rangle$$

Now, the y component of the gradient is positive and so this vector will generally point in the positive y direction. However, as noted above we need the normal vector point in the negative y direction to make sure that it will be pointing away from the enclosed region. This means that we will need to use

$$\vec{n} = \frac{-\nabla f}{\|-\nabla f\|} = \frac{\langle 2x, -1, 2z \rangle}{\|\nabla f\|}$$

Let's note a couple of things here before we proceed. We don't really need to divide this by the magnitude of the gradient since this will just cancel out once we actually do the integral. So, because of this we didn't bother computing it. Also, the dropping of the minus sign is not a typo. When we compute the magnitude we are going to square each of the components and so the minus sign will drop out.

S_1 : The Paraboloid

Okay, here is the surface integral in this case.

$$\begin{aligned}
\iint_{S_1} \vec{F} \cdot d\vec{S} &= \iint_D (y \vec{j} - z \vec{k}) \cdot \left(\frac{\langle 2x, -1, 2z \rangle}{\|\nabla f\|} \right) \|\nabla f\| dA \\
&= \iint_D -y - 2z^2 dA \\
&= \iint_D -(x^2 + z^2) - 2z^2 dA \\
&= -\iint_D x^2 + 3z^2 dA
\end{aligned}$$

Don't forget that we need to plug in the equation of the surface for y before we actually compute the integral. In this case D is the disk of radius 1 in the xz -plane and so it makes sense to use polar coordinates to complete this integral. Here are polar coordinates for this region.

$$\begin{aligned}
x &= r \cos \theta & z &= r \sin \theta \\
0 \leq \theta &\leq 2\pi & 0 \leq r &\leq 1
\end{aligned}$$

Note that we kept the x conversion formula the same as the one we are used to using for x and let z be the formula that used the sine. We could have done it any order, however in this way we are at least working with one of them as we are used to working with.

Here is the evaluation of this integral.

$$\begin{aligned}
\iint_{S_1} \vec{F} \cdot d\vec{S} &= -\iint_D x^2 + 3z^2 dA \\
&= -\int_0^{2\pi} \int_0^1 (r^2 \cos^2 \theta + 3r^2 \sin^2 \theta) r dr d\theta \\
&= -\int_0^{2\pi} \int_0^1 (\cos^2 \theta + 3 \sin^2 \theta) r^3 dr d\theta \\
&= -\int_0^{2\pi} \left(\frac{1}{2}(1 + \cos(2\theta)) + \frac{3}{2}(1 - \cos(2\theta)) \right) \left(\frac{1}{4} r^4 \right) \Big|_0^1 d\theta \\
&= -\frac{1}{8} \int_0^{2\pi} 4 - 2 \cos(2\theta) d\theta \\
&= -\frac{1}{8} (4\theta - \sin(2\theta)) \Big|_0^{2\pi} \\
&= -\pi
\end{aligned}$$

S_2 : The Cap of the Paraboloid

We can now do the surface integral on the disk (cap on the paraboloid). This one is actually fairly easy to do and in fact we can use the definition of the surface integral directly. First let's notice that the disk is really just the portion of the plane $y = 1$ that is in front of the disk of radius 1 in the xz -plane.

Now we want the unit normal vector to point away from the enclosed region and since it must

also be orthogonal to the plane $y = 1$ then it must point in a direction that is parallel to the y -axis, but we already have a unit vector that does this. Namely,

$$\vec{n} = \vec{j}$$

the standard unit basis vector. It also points in the correct direction for us to use. Because we have the vector field and the normal vector we can plug directly into the definition of the surface integral to get,

$$\iint_{S_2} \vec{F} \cdot d\vec{S} = \iint_{S_2} (y\vec{j} - z\vec{k}) \cdot (\vec{j}) dS = \iint_{S_2} y dS$$

At this point we need to plug in for y (since S_2 is a portion of the plane $y = 1$ we do know what it is) and we'll also need the square root this time when we convert the surface integral over to a double integral. In this case since we are using the definition directly we won't get the canceling of the square root that we saw with the first portion. To get the square root we'll need to acknowledge that

$$y = 1 = g(x, z)$$

and so the square root is,

$$\sqrt{(g_x)^2 + 1 + (g_z)^2}$$

The surface integral is then,

$$\begin{aligned} \iint_{S_2} \vec{F} \cdot d\vec{S} &= \iint_{S_2} y dS \\ &= \iint_D 1\sqrt{0+1+0} dA = \iint_D dA \end{aligned}$$

At this point we can acknowledge that D is a disk of radius 1 and this double integral is nothing more than the double integral that will give the area of the region D so there is no reason to compute the integral. Here is the value of the surface integral.

$$\iint_{S_2} \vec{F} \cdot d\vec{S} = \pi$$

Finally, to finish this off we just need to add the two parts up. Here is the surface integral that we were actually asked to compute.

$$\iint_S \vec{F} \cdot d\vec{S} = \iint_{S_1} \vec{F} \cdot d\vec{S} + \iint_{S_2} \vec{F} \cdot d\vec{S} = -\pi + \pi = 0$$

Example 2 Evaluate $\iint_S \vec{F} \cdot d\vec{S}$ where $\vec{F} = x\vec{i} + y\vec{j} + z^4\vec{k}$ and S is the upper half the sphere

$x^2 + y^2 + z^2 = 9$ and the disk $x^2 + y^2 \leq 9$ in the plane $z = 0$. Assume that S has the positive orientation.

Solution

So, as with the previous problem we have a closed surface and since we are also told that the surface has a positive orientation all the unit normal vectors must point away from the enclosed region. To help us visualize this here is a sketch of the surface.

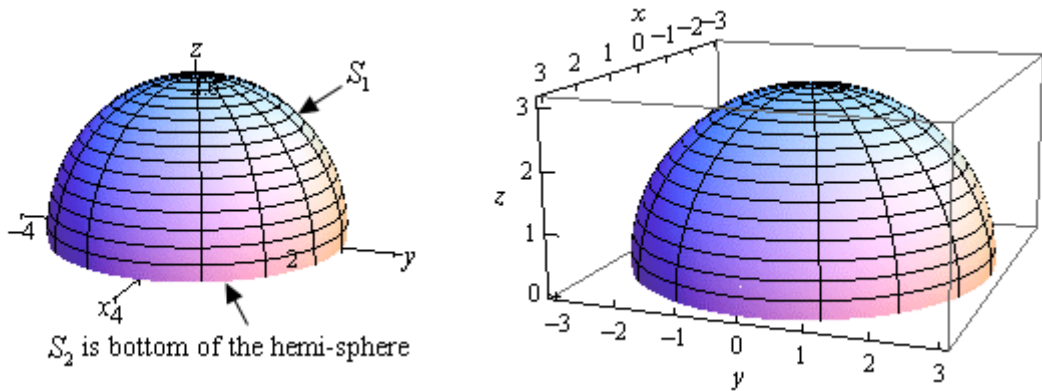

We will call S_1 the hemisphere and S_2 will be the bottom of the hemisphere (which isn't shown on the sketch). Now, in order for the unit normal vectors on the sphere to point away from enclosed region they will all need to have a positive z component. Remember that the vector must be normal to the surface and if there is a positive z component and the vector is normal it will have to be pointing away from the enclosed region.

On the other hand, the unit normal on the bottom of the disk must point in the negative z direction in order to point away from the enclosed region.

S_1 : The Sphere

Let's do the surface integral on S_1 first. In this case since the surface is a sphere we will need to use the parametric representation of the surface. This is,

$$\vec{r}(\theta, \varphi) = 3 \sin \varphi \cos \theta \vec{i} + 3 \sin \varphi \sin \theta \vec{j} + 3 \cos \varphi \vec{k}$$

Since we are working on the hemisphere here are the limits on the parameters that we'll need to use.

$$0 \leq \theta \leq 2\pi \qquad 0 \leq \varphi \leq \frac{\pi}{2}$$

Next, we need to determine $\vec{r}_\theta \times \vec{r}_\varphi$. Here are the two individual vectors and the cross product.

$$\begin{aligned} \vec{r}_\theta(\theta, \varphi) &= -3 \sin \varphi \sin \theta \vec{i} + 3 \sin \varphi \cos \theta \vec{j} \\ \vec{r}_\varphi(\theta, \varphi) &= 3 \cos \varphi \cos \theta \vec{i} + 3 \cos \varphi \sin \theta \vec{j} - 3 \sin \varphi \vec{k} \end{aligned}$$

$$\begin{aligned} \vec{r}_\theta \times \vec{r}_\varphi &= \begin{vmatrix} \vec{i} & \vec{j} & \vec{k} \\ -3 \sin \varphi \sin \theta & 3 \sin \varphi \cos \theta & 0 \\ 3 \cos \varphi \cos \theta & 3 \cos \varphi \sin \theta & -3 \sin \varphi \end{vmatrix} \\ &= -9 \sin^2 \varphi \cos \theta \vec{i} - 9 \sin \varphi \cos \varphi \sin^2 \theta \vec{k} - 9 \sin^2 \varphi \sin \theta \vec{j} - 9 \sin \varphi \cos \varphi \cos^2 \theta \vec{k} \\ &= -9 \sin^2 \varphi \cos \theta \vec{i} - 9 \sin^2 \varphi \sin \theta \vec{j} - 9 \sin \varphi \cos \varphi (\sin^2 \theta + \cos^2 \theta) \vec{k} \\ &= -9 \sin^2 \varphi \cos \theta \vec{i} - 9 \sin^2 \varphi \sin \theta \vec{j} - 9 \sin \varphi \cos \varphi \vec{k} \end{aligned}$$

Note that we won't need the magnitude of the cross product since that will cancel out once we start doing the integral.

Notice that for the range of φ that we've got both sine and cosine are positive and so this vector will have a negative z component and as we noted above in order for this to point away from the enclosed area we will need the z component to be positive. Therefore we will need to use the following vector for the unit normal vector.

$$\vec{n} = -\frac{\vec{r}_\theta \times \vec{r}_\varphi}{\|\vec{r}_\theta \times \vec{r}_\varphi\|} = \frac{9 \sin^2 \varphi \cos \theta \vec{i} + 9 \sin^2 \varphi \sin \theta \vec{j} + 9 \sin \varphi \cos \varphi \vec{k}}{\|\vec{r}_\theta \times \vec{r}_\varphi\|}$$

Again, we will drop the magnitude once we get to actually doing the integral since it will just cancel in the integral.

Okay, next we'll need

$$\vec{F}(\vec{r}(\theta, \varphi)) = 3 \sin \varphi \cos \theta \vec{i} + 3 \sin \varphi \sin \theta \vec{j} + 81 \cos^4 \varphi \vec{k}$$

Remember that in this evaluation we are just plugging in the x component of $\vec{r}(\theta, \varphi)$ into the vector field *etc.*

We also may as well get the dot product out of the way that we know we are going to need.

$$\begin{aligned} \vec{F}(\vec{r}(\theta, \varphi)) \cdot (\vec{r}_\theta \times \vec{r}_\varphi) &= 27 \sin^3 \varphi \cos^2 \theta + 27 \sin^3 \varphi \sin^2 \theta + 729 \sin \varphi \cos^5 \varphi \\ &= 27 \sin^3 \varphi + 729 \sin \varphi \cos^5 \varphi \end{aligned}$$

Now we can do the integral.

$$\begin{aligned} \iint_{S_1} \vec{F} \cdot d\vec{S} &= \iint_D \vec{F} \cdot \left(\frac{\vec{r}_u \times \vec{r}_v}{\|\vec{r}_u \times \vec{r}_v\|} \right) \|\vec{r}_\theta \times \vec{r}_\varphi\| dA \\ &= \int_0^{2\pi} \int_0^{\frac{\pi}{2}} 27 \sin^3 \varphi + 729 \sin \varphi \cos^5 \varphi d\varphi d\theta \\ &= \int_0^{2\pi} \int_0^{\frac{\pi}{2}} 27 \sin \varphi (1 - \cos^2 \varphi) + 729 \sin \varphi \cos^5 \varphi d\varphi d\theta \\ &= - \int_0^{2\pi} \left(27 \left(\cos \varphi - \frac{1}{3} \cos^3 \varphi \right) + \frac{729}{6} \cos^6 \varphi \right) \Big|_0^{\frac{\pi}{2}} d\theta \\ &= \int_0^{2\pi} \frac{279}{2} d\theta \\ &= 279\pi \end{aligned}$$

S_1 : The Bottom of the Hemi-Sphere

Now, we need to do the integral over the bottom of the hemisphere. In this case we are looking at the disk $x^2 + y^2 \leq 9$ that lies in the plane $z = 0$ and so the equation of this surface is actually $z = 0$. The disk is really the region D that tells us how much of the surface we are going to use.

This also means that we can use the definition of the surface integral here with

$$\vec{n} = -\vec{k}$$

We need the negative since it must point away from the enclosed region.

The surface integral in this case is,

$$\begin{aligned}\iint_{S_2} \vec{F} \cdot d\vec{S} &= \iint_{S_2} (x\vec{i} + y\vec{j} + z^4\vec{k}) \cdot (-\vec{k}) dS \\ &= \iint_{S_2} -z^4 dS\end{aligned}$$

Remember, however, that we are in the plane given by $z = 0$ and so the surface integral becomes,

$$\iint_{S_2} \vec{F} \cdot d\vec{S} = \iint_{S_2} -z^4 dS = \iint_{S_2} 0 dS = 0$$

The last step is to then add the two pieces up. Here is surface integral that we were asked to look at.

$$\iint_S \vec{F} \cdot d\vec{S} = \iint_{S_1} \vec{F} \cdot d\vec{S} + \iint_{S_2} \vec{F} \cdot d\vec{S} = 279\pi + 0 = 279\pi$$

We will leave this section with a quick interpretation of a surface integral over a vector field. If \vec{v} is the velocity field of a fluid then the surface integral

$$\iint_S \vec{v} \cdot d\vec{S}$$

represents the volume of fluid flowing through S per time unit (*i.e.* per second, per minute, or whatever time unit you are using).

Stokes' Theorem

In this section we are going to take a look at a theorem that is a higher dimensional version of [Green's Theorem](#). In Green's Theorem we related a line integral to a double integral over some region. In this section we are going to relate a line integral to a surface integral. However, before we give the theorem we first need to define the curve that we're going to use in the line integral.

Let's start off with the following surface with the indicated orientation.

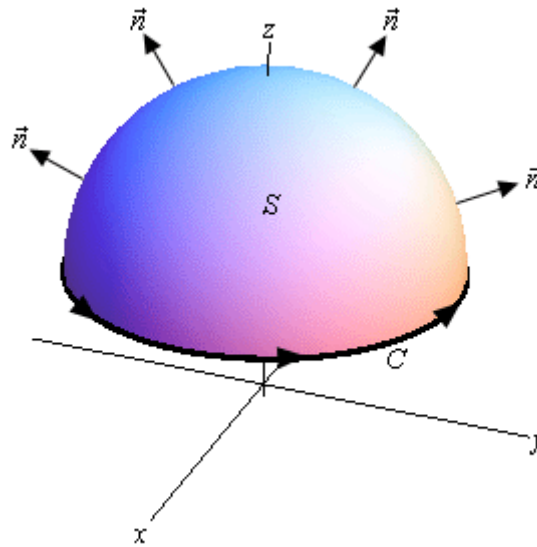

Around the edge of this surface we have a curve C . This curve is called the **boundary curve**. The orientation of the surface S will induce the **positive orientation of C** . To get the positive orientation of C think of yourself as walking along the curve. While you are walking along the curve if your head is pointing in the same direction as the unit normal vectors while the surface is on the left then you are walking in the positive direction on C .

Now that we have this curve definition out of the way we can give Stokes' Theorem.

Stokes' Theorem

Let S be an oriented smooth surface that is bounded by a simple, closed, smooth boundary curve C with positive orientation. Also let \vec{F} be a vector field then,

$$\int_C \vec{F} \cdot d\vec{r} = \iint_S \text{curl } \vec{F} \cdot d\vec{S}$$

In this theorem note that the surface S can actually be any surface so long as its boundary curve is given by C . This is something that can be used to our advantage to simplify the surface integral on occasion.

Let's take a look at a couple of examples.

Example 1 Use Stokes' Theorem to evaluate $\iint_S \text{curl } \vec{F} \cdot d\vec{S}$ where $\vec{F} = z^2 \vec{i} - 3xy \vec{j} + x^3 y^3 \vec{k}$ and S is the part of $z = 5 - x^2 - y^2$ above the plane $z = 1$. Assume that S is oriented upwards.

Solution

Let's start this off with a sketch of the surface.

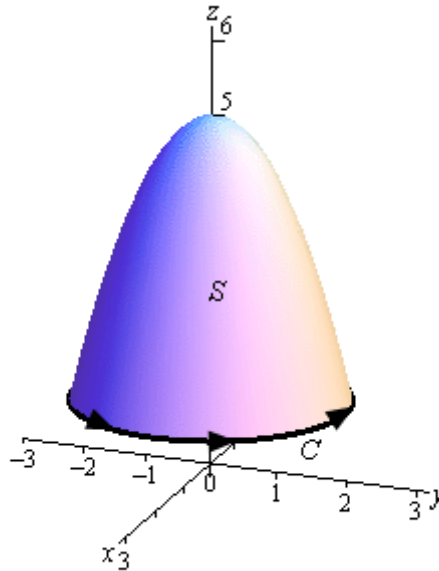

In this case the boundary curve C will be where the surface intersects the plane $z = 1$ and so will be the curve

$$\begin{aligned} 1 &= 5 - x^2 - y^2 \\ x^2 + y^2 &= 4 && \text{at } z = 1 \end{aligned}$$

So, the boundary curve will be the circle of radius 2 that is in the plane $z = 1$. The parameterization of this curve is,

$$\vec{r}(t) = 2 \cos t \vec{i} + 2 \sin t \vec{j} + \vec{k}, \quad 0 \leq t \leq 2\pi$$

The first two components give the circle and the third component makes sure that it is in the plane $z = 1$.

Using Stokes' Theorem we can write the surface integral as the following line integral.

$$\iint_S \text{curl } \vec{F} \cdot d\vec{S} = \int_C \vec{F} \cdot d\vec{r} = \int_0^{2\pi} \vec{F}(\vec{r}(t)) \cdot \vec{r}'(t) dt$$

So, it looks like we need a couple of quantities before we do this integral. Let's first get the vector field evaluated on the curve. Remember that this is simply plugging the components of the parameterization into the vector field.

$$\begin{aligned} \vec{F}(\vec{r}(t)) &= (1)^2 \vec{i} - 3(2 \cos t)(2 \sin t) \vec{j} + (2 \cos t)^3 (2 \sin t)^3 \vec{k} \\ &= \vec{i} - 12 \cos t \sin t \vec{j} + 64 \cos^3 t \sin^3 t \vec{k} \end{aligned}$$

Next, we need the derivative of the parameterization and the dot product of this and the vector field.

$$\begin{aligned}\vec{r}'(t) &= -2 \sin t \vec{i} + 2 \cos t \vec{j} \\ \vec{F}(\vec{r}(t)) \cdot \vec{r}'(t) &= -2 \sin t - 24 \sin t \cos^2 t\end{aligned}$$

We can now do the integral.

$$\begin{aligned}\iint_S \text{curl } \vec{F} \cdot d\vec{S} &= \int_0^{2\pi} -2 \sin t - 24 \sin t \cos^2 t \, dt \\ &= \left(2 \cos t + 8 \cos^3 t \right) \Big|_0^{2\pi} \\ &= 0\end{aligned}$$

Example 2 Use Stokes' Theorem to evaluate $\int_C \vec{F} \cdot d\vec{r}$ where $\vec{F} = z^2 \vec{i} + y^2 \vec{j} + x \vec{k}$ and C is the triangle with vertices $(1, 0, 0)$, $(0, 1, 0)$ and $(0, 0, 1)$ with counter-clockwise rotation.

Solution

We are going to need the curl of the vector field eventually so let's get that out of the way first.

$$\text{curl } \vec{F} = \begin{vmatrix} \vec{i} & \vec{j} & \vec{k} \\ \frac{\partial}{\partial x} & \frac{\partial}{\partial y} & \frac{\partial}{\partial z} \\ z^2 & y^2 & x \end{vmatrix} = 2z \vec{j} - \vec{j} = (2z - 1) \vec{j}$$

Now, all we have is the boundary curve for the surface that we'll need to use in the surface integral. However, as noted above all we need is any surface that has this as its boundary curve. So, let's use the following plane with upwards orientation for the surface.

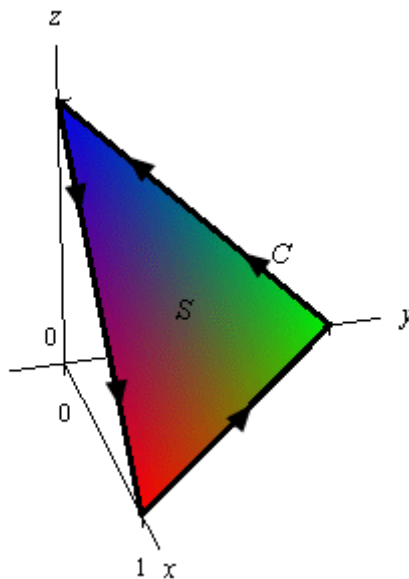

Since the plane is oriented upwards this induces the positive direction on C as shown. The equation of this plane is,

$$x + y + z = 1 \quad \Rightarrow \quad z = g(x, y) = 1 - x - y$$

Now, let's use Stokes' Theorem and get the surface integral set up.

$$\begin{aligned} \int_C \vec{F} \cdot d\vec{r} &= \iint_S \text{curl } \vec{F} \cdot d\vec{S} \\ &= \iint_S (2z - 1)\vec{j} \cdot d\vec{S} \\ &= \iint_D (2z - 1)\vec{j} \cdot \frac{\nabla f}{\|\nabla f\|} \|\nabla f\| dA \end{aligned}$$

Okay, we now need to find a couple of quantities. First let's get the gradient. Recall that this comes from the function of the surface.

$$\begin{aligned} f(x, y, z) &= z - g(x, y) = z - 1 + x + y \\ \nabla f &= \vec{i} + \vec{j} + \vec{k} \end{aligned}$$

Note as well that this also points upwards and so we have the correct direction.

Now, D is the region in the xy -plane shown below,

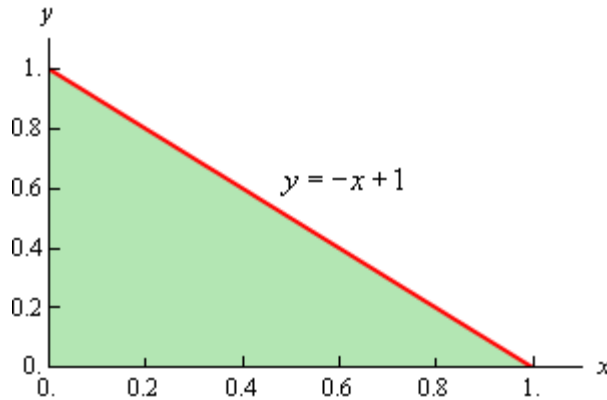

We get the equation of the line by plugging in $z = 0$ into the equation of the plane. So based on this the ranges that define D are,

$$0 \leq x \leq 1 \quad 0 \leq y \leq -x + 1$$

The integral is then,

$$\begin{aligned} \int_C \vec{F} \cdot d\vec{r} &= \iint_D (2z - 1)\vec{j} \cdot (\vec{i} + \vec{j} + \vec{k}) dA \\ &= \int_0^1 \int_0^{-x+1} 2(1 - x - y) - 1 dy dx \end{aligned}$$

Don't forget to plug in for z since we are doing the surface integral on the plane. Finishing this out gives,

$$\begin{aligned}\int_C \vec{F} \cdot d\vec{r} &= \int_0^1 \int_0^{-x+1} 1 - 2x - 2y \, dy \, dx \\ &= \int_0^1 (y - 2xy - y^2) \Big|_0^{-x+1} \, dx \\ &= \int_0^1 x^2 - x \, dx \\ &= \left(\frac{1}{3}x^3 - \frac{1}{2}x^2 \right) \Big|_0^1 \\ &= -\frac{1}{6}\end{aligned}$$

In both of these examples we were able to take an integral that would have been somewhat unpleasant to deal with and by the use of Stokes' Theorem we were able to convert it into an integral that wasn't too bad.

Divergence Theorem

In this section we are going to relate surface integrals to triple integrals. We will do this with the Divergence Theorem.

Divergence Theorem

Let E be a simple solid region and S is the boundary surface of E with positive orientation. Let \vec{F} be a vector field whose components have continuous first order partial derivatives. Then,

$$\iint_S \vec{F} \cdot d\vec{S} = \iiint_E \operatorname{div} \vec{F} \, dV$$

Let's see an example of how to use this theorem.

Example 1 Use the divergence theorem to evaluate $\iint_S \vec{F} \cdot d\vec{S}$ where $\vec{F} = xy\vec{i} - \frac{1}{2}y^2\vec{j} + z\vec{k}$ and the surface consists of the three surfaces, $z = 4 - 3x^2 - 3y^2$, $1 \leq z \leq 4$ on the top, $x^2 + y^2 = 1$, $0 \leq z \leq 1$ on the sides and $z = 0$ on the bottom.

Solution

Let's start this off with a sketch of the surface.

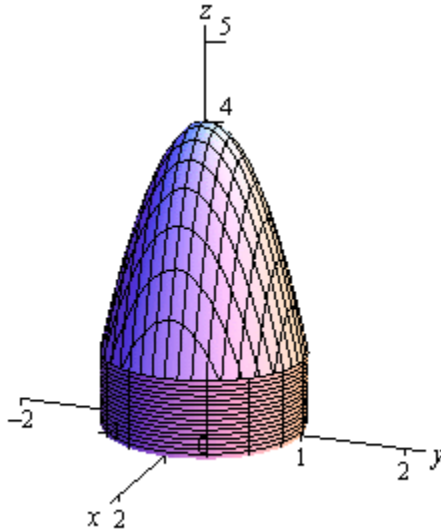

The region E for the triple integral is then the region enclosed by these surfaces. Note that cylindrical coordinates would be a perfect coordinate system for this region. If we do that here are the limits for the ranges.

$$0 \leq z \leq 4 - 3r^2$$

$$0 \leq r \leq 1$$

$$0 \leq \theta \leq 2\pi$$

We'll also need the divergence of the vector field so let's get that.

$$\operatorname{div} \vec{F} = y - y + 1 = 1$$

The integral is then,

$$\begin{aligned}\iint_S \vec{F} \cdot d\vec{S} &= \iiint_E \operatorname{div} \vec{F} \, dV \\ &= \int_0^{2\pi} \int_0^1 \int_0^{4-3r^2} r \, dz \, dr \, d\theta \\ &= \int_0^{2\pi} \int_0^1 4r - 3r^3 \, dr \, d\theta \\ &= \int_0^{2\pi} \left(2r^2 - \frac{3}{4}r^4 \right) \Big|_0^1 \, d\theta \\ &= \int_0^{2\pi} \frac{5}{4} \, d\theta \\ &= \frac{5}{2}\pi\end{aligned}$$